

PROCESS-SPECIFIC DESIGN

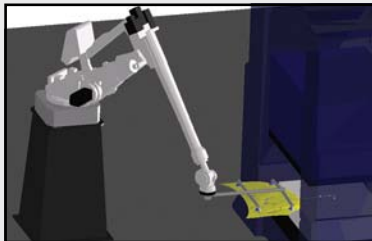

MOTOSIM® EG OFF-LINE PROGRAMMING (optional)



OPTIONAL PARALLEL LINK TOOL

FEATURES

- 3,505-mm (138") horizontal reach
- 2,629-mm (103.5") vertical reach
- Up to 12 strokes per minute with 6.5 m (21.33') pitch
- Slim, space-saving design
- Extended reach to service presses with spacing up to 9 m (29.53')
- Internally routed air and I/O signal lines to simplify integration
- LIFE program (optional)
- Parallel link tool to extend reach and maintain part orientation throughout the stamping line (optional)



EPH4000N

• PRESS TENDING •

Fast, Streamlined and Powerful

The six-axis, Motoman® EPH4000N “Expert Press Handling” robot is a high-speed, shelf-mounted manipulator designed specifically for extreme duty cycle press handling applications. The robot features an oversized S-axis drive for these high duty cycle applications. The high-performance, vertically articulated EPH4000N robot features a 200 kg (441 lb) payload, a 3,505 mm (138") horizontal reach and 2,629 mm (103.5") vertical reach. Its fast axis speeds reduce cycle times and increase production throughput.

The EPH4000N robot can achieve 12 strokes per minute with a press pitch of 6.5 m (21.33 ft). Extended reach allows the EPH4000N to service presses with press pitches of up to 9 m (29.53 ft). The slender design of the EPH4000N allows it to work in tight spaces and service multiple presses.

MotoSim EG

Available as an option, MotoSim EG is PC-based, simulation and off-line programming software that can be used during system design to optimize the layout. For new parts, MotoSim EG can be used to optimize tool design and program the robots, minimizing production downtime.

Advanced NX100 Controller

The NX100 high-performance controller features a Windows® CE programming pendant, fast processing, easy-to-use INFORM III programming language, and robust PC architecture.

The NX100 offers unmatched multiple robot control capability (up to four robots) to minimize cost of integration and eliminate risk of robot collisions.

The NX100 includes four security levels of password protection (user, editor, maintenance and supervisor) for up to 100 individual users. Password use restricts access to the production programs and the controller logs any changes.

The programming pendant features a color touch-screen display that can be configured as a custom HMI with buttons and status indicators.

Dual-channel safety features include enhanced E-Stop functionality, integrated speed monitoring, manual brake release switches, and compliance with both ANSI/RIA R15.06-1999 and Canadian safety standards.

The NX100 offers unmatched connectivity through standard Ethernet and other network options: DeviceNet, ControlNet, Profibus-DP and EtherNet/IP.

EPH4000N ROBOT

All dimensions are metric (mm) and for reference only. Please request detail drawings for all design/engineering requirements.

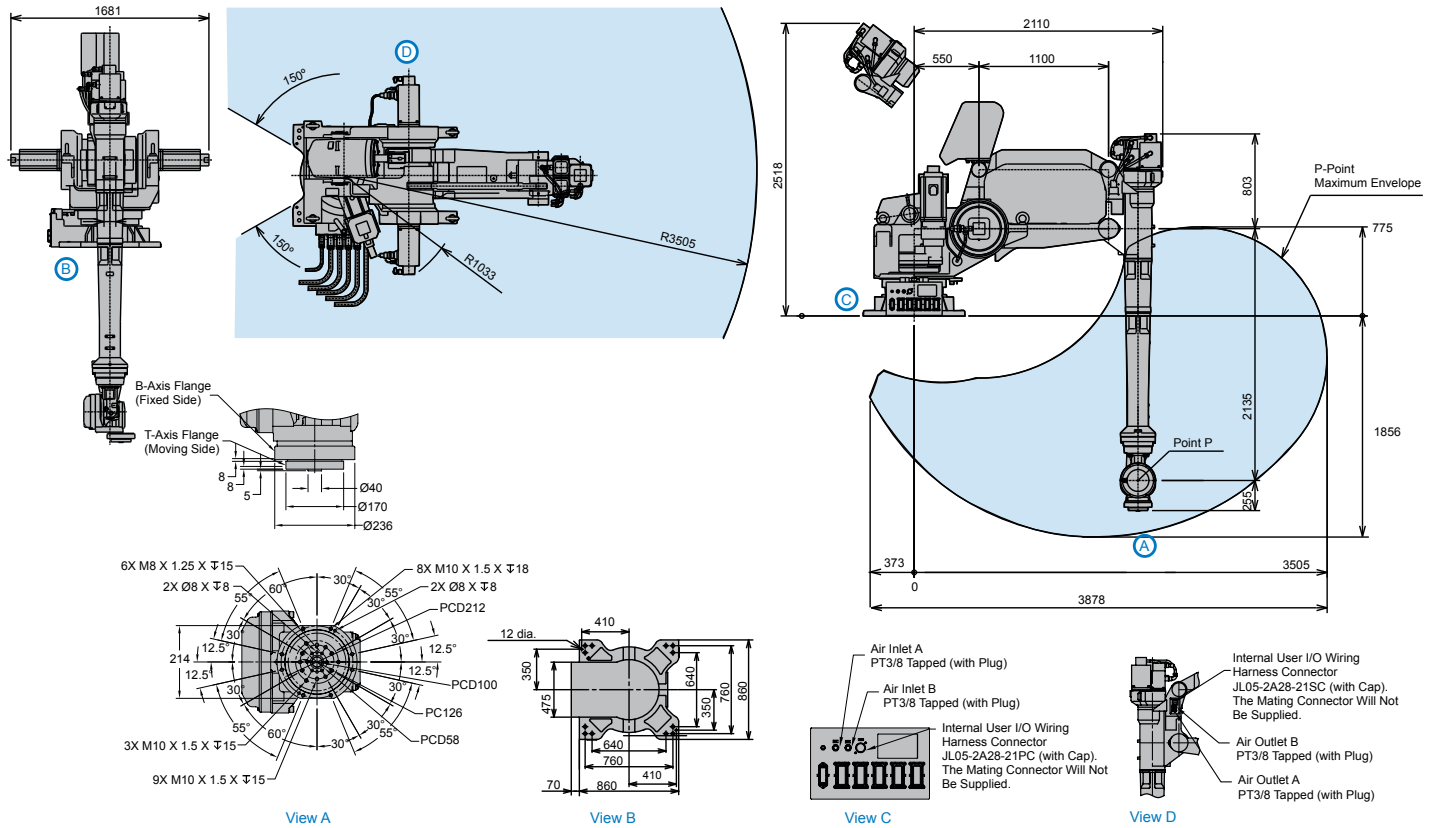

EPH4000N SPECIFICATIONS

Structure		Vertical articulated type
Controlled Axes		6
Payload		200 kg (441 lbs.)
Vertical Reach		2,629 mm (103.5")
Horizontal Reach		3,505 mm (138")
Repeatability		±0.5 mm (0.02")
Maximum Motion Range	S-Axis (Turning/Sweep)	±150°
	L-Axis (Lower Arm)	+25°/-122°
	U-Axis (Upper Arm)	+53°/-70°
	R-Axis (Wrist Roll)	±360°
	B-Axis (Bend/Pitch/Yaw)	±120°
	T-Axis (Wrist Twist)	±360°
Maximum Speed	S-Axis	90°/s
	L-Axis	90°/s
	U-Axis	90°/s
	R-Axis	80°/s
	B-Axis	80°/s
	T-Axis	160°/s
Approximate Mass		3,050 kg (6,725.3 lbs.)
Brakes		All axes
Power Consumption		22 kVA
Allowable Moment	R-Axis	1,274 N · m
	B-Axis	2,156 N · m
	T-Axis*	0 N · m
Allowable Moment of Inertia	R-Axis	84.5 kg · m ²
	B-Axis	330 kg · m ²
	T-Axis*	80 kg · m ²
I/O Lines		34 wires (0.5mm ²)
Air Lines		2 - 3/8" air lines

*Rating with T-Axis parallel to the floor.
Note: The EPH4000N offers a longer life S-axis drive system and higher vibration rating when compared to the EP4000N.

NX100 CONTROLLER SPECIFICATIONS*

Structure	Free-standing, enclosed type
Dimensions (mm)	650 (w) x 1,200 (h) x 650 (d) (25.6" x 47.2" x 25.6")
Approximate Mass	150-250 kg (330.8-551.3 lbs.)
Cooling System	Indirect cooling
Ambient Temperature	During operation: 0° C (32° F) to 45° C (113° F) During transit and storage: -10° C (14° F) to 60° C (140° F)
Relative Humidity	90% max. non-condensing
Primary Power Requirements	3-phase, 240/480/575 VAC at 50/60 Hz
Grounding	Grounding resistance: ≤100 ohms Separate ground required
Digital I/O	Standard I/O: 40 inputs/40 outputs consisting of 16 system inputs/16 system outputs, 24 user inputs/24 user outputs Enabled to 1,024 inputs/1,024 outputs
Position Feedback	By absolute encoder
Drive Units	Servo packs for AC servo motors
Accel/Decel	Software servo control
Program Memory	60,000 steps 10,000 ladder instructions
Pendant Dim. (mm)	199 (w) x 338 (h) x 60 (d) (7.8" x 13.3" x 2.4")
Pendant Playback Buttons	Teach, Play, Remote, Servo On, Start, Hold, Emergency Stop, Edit Lock (Play Mode Enabled on Controller)
Concurrent I/O Ladder	10,000 Instructions
Multi Tasking	Up to 8 concurrent jobs
Fieldbus	DeviceNet Master/Slave, AB RIO, Profibus, Interbus-S, M-Net, CC Link, EtherNet IP/Slave
Ethernet	10 Base T/100 Base TX
E-Stop	Controlled stop
Safety	Dual-channel Emergency Stop Pushbuttons, 3-position Enable Switch, Manual Brake Release Meets ANSI/RIA R15.06-1999 and Canadian safety standards

*See NX100 Controller data sheet (DS-232) for complete specifications

www.motoman.com



MOTOMAN ROBOTICS
100 AUTOMATION WAY, MIAMISBURG, OHIO 45342
TEL: 937.847.6200 ■ FAX: 937.847.6277

MOTOMAN IS A REGISTERED TRADEMARK
WINDOWS IS A REGISTERED TRADEMARK OF MICROSOFT
ALL OTHER MARKS ARE THE TRADEMARKS AND REGISTERED TRADEMARKS OF YASKAWA AMERICA, INC.