

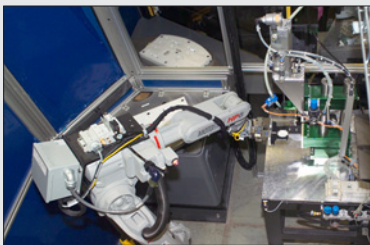

MULTIPLE ROBOT CONTROL

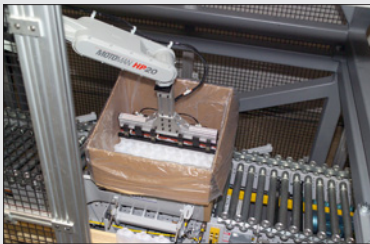

MATERIAL HANDLING



PACKAGING

TOP REASONS TO BUY

- Exceptionally fast robot with wide range of motion provides flexibility
- Small interference radius reduces floorspace requirements
- High repeatability provides precision needed for a wide variety of applications



CUTTING • DISPENSING • HANDLING • MACHINE TENDING
MATERIAL REMOVAL • PACKAGING • WELDING

Model Options:

- 20 kg Payload (HP20D and HP20RD)
- 6 kg Payload (HP20D-6)
- Shelf-Mount (HP20RD)

Versatile, High-Speed Robots

- Fast, versatile six-axis HP20D, extended-reach HP20D-6 and shelf-mount HP20RD robots offer superior, high-speed performance in handling, machine tending, packaging, cutting and dispensing applications.
- HP20D model: 20 kg (44.1 lb) payload; 1,717 mm (67.6") horizontal reach; 3,063 mm (120.6") vertical reach; ± 0.06 mm (0.002") repeatability.
- Extended-reach HP20D-6 version for applications requiring a larger work envelope: 6 kg (13.2 lb) payload; 1,915 mm (75.4") horizontal reach; 3,459 mm (136.2") vertical reach; ± 0.06 mm (0.002") repeatability.
- The shelf-mounted HP20RD is designed for injection molding and other similar applications: 20 kg (44.1 lb) payload; 2,017 mm (79.4") horizontal reach; 3,134 mm (123.4") vertical reach; ± 0.06 mm (0.002") repeatability.
- Powerful design with high moment of inertia ratings.
- Slim base, waist and arm allow robot to be placed close to workpiece holding fixtures to improve part accessibility.
- Fast axial speeds and acceleration reduce cycle times and increase production output.

- Compact design and advanced collision avoidance features with multiple robot control allow up to eight robots (72 axes) to be used together to maximize productivity while minimizing overall floorspace requirements.
- Floor-, wall- or ceiling-mounted versions available for the HP20D and HP20D-6 models.

DX100 Controller

- Patented multiple robot control supports up to 8 robots/72 axes.
- Windows® CE programming pendant with color touch screen and USB interface.
- Faster processing speeds for smoother interpolation. Quicker I/O response. Accelerated Ethernet communication.
- Extensive I/O suite includes integral PLC and touch screen HMI, 2,048 I/O and graphical ladder editor.
- Supports all major fieldbus networks, including EtherNet/IP, DeviceNet, Profibus-DP and many others.
- Compliant to ANSI/RIA R15.06-1999 and other relevant ISO and CSA safety standards. Optional Category 3 functional safety unit.

HP20D/HP20RD/HP20D-6 ROBOT

HP20D robot shown.
All dimensions are metric (mm) and for reference only. Please request detail drawings for all design/engineering requirements.

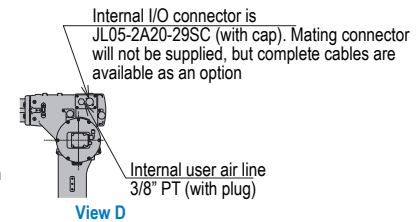
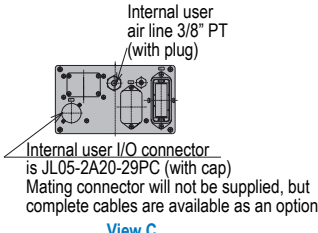
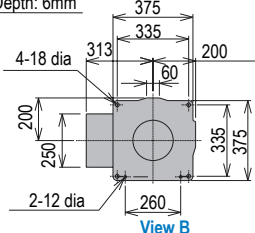
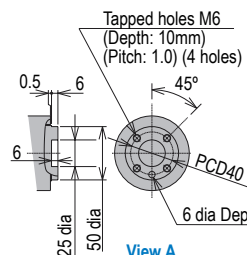
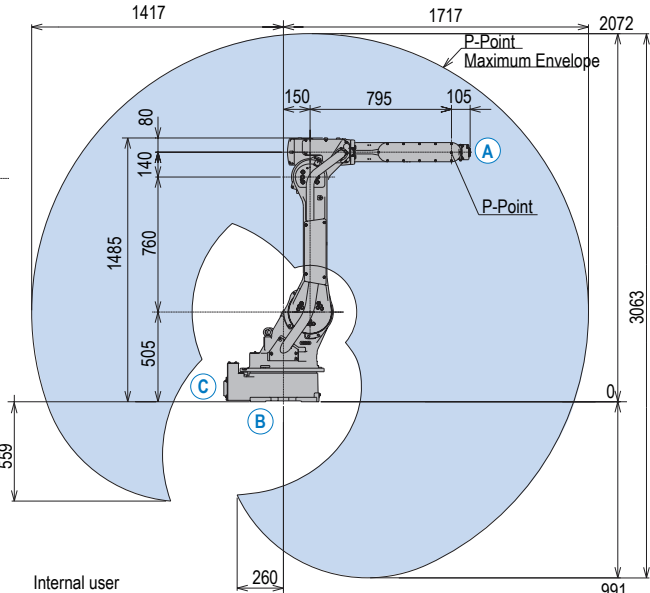
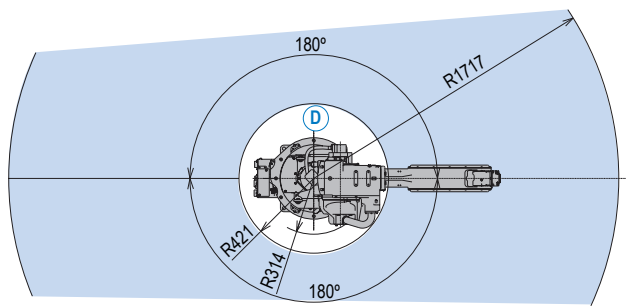

ROBOT SPECIFICATIONS

	HP20D	HP20D-6	HP20RD Shelf-mount
Structure	Vertical jointed-arm type	Vertical jointed-arm type	Vertical jointed-arm type
Controlled Axes	6	6	6
Payload	20 kg (44.1 lbs)	6 kg (13.2 lbs)	20 kg (44.1 lbs)
Vertical Reach	3,063 mm (120.6")	3,459 mm (136.2")	3,134 mm (123.4")
Horizontal Reach	1,717 mm (67.6")	1,915 mm (75.4")	2,017 mm (79.4")
Repeatability	±0.06 mm (±0.002")	±0.06 mm (±0.002")	±0.06 mm (±0.002")
Maximum Motion Range	S-Axis (Turning) ±180° L-Axis (Lower Arm) +155°/-100° U-Axis (Upper Arm) +255°/-165° R-Axis (Upper Arm Twist) ±200° B-Axis (Pitch/Yaw) +230°/-50° T-Axis (Twist) ±360°	±180° +155°/-100° +255°/-165° ±200° +230°/-50° ±360°	+125°/-110° +105°/-130° +310°/-115° ±200° ±140° ±360°
Maximum Speed	S-Axis 197°/s L-Axis 175°/s U-Axis 187°/s R-Axis 400°/s B-Axis 400°/s T-Axis 600°/s	197°/s 175°/s 187°/s 400°/s 400°/s 600°/s	180°/s 175°/s 187°/s 400°/s 400°/s 600°/s
Approximate Mass	268 kg (590.9 lbs)	273 kg (602 lbs)	293 kg (646.1 lbs)
Brakes	All axes	All axes	All axes
Power Consumption	2.0 kVA	2.8 kVA	2.0 kVA
Allowable Moment	R-Axis 39.2 N·m B-Axis 39.2 N·m T-Axis 19.6 N·m	11.8 N·m 9.8 N·m 5.9 N·m	39.2 N·m 39.2 N·m 19.6 N·m
Allowable Moment of Inertia	R-Axis 1.05 kg·m² B-Axis 1.05 kg·m² T-Axis 0.75 kg·m²	0.24 kg·m² 0.17 kg·m² 0.06 kg·m²	1.05 kg·m² 1.05 kg·m² 0.75 kg·m²

DX100 CONTROLLER SPECIFICATIONS**

Dimensions (mm)	800 (w) x 1,000 (h) x 650 (d) (31.5" x 39.4" x 25.6")
Approximate Mass	250 kg max. (551.3 lbs)
Cooling System	Indirect cooling
Ambient Temperature	During operation: 0° to 45° C (32° to 113° F) During transit and storage: -10° to 60° C (14° to 140° F)
Relative Humidity	90% max. non-condensing
Primary Power Requirements	3-phase, 240/480/575 VAC at 50/60 Hz
Digital I/O	Standard I/O: 40 inputs/40 outputs consisting of 16 system inputs/16 system outputs, 24 user inputs/24 user outputs NPN-Standard PNP-Optional 32 Transistor Outputs; 8 Relay Outputs Max. I/O (optional): 2,048 inputs and 2,048 outputs
Position Feedback	By absolute encoder
Program Memory	JOB: 200,000 steps, 10,000 instructions CIO Ladder Standard: 15,000 steps Expanded: 20,000 steps
Pendant Dim. (mm)	169 (w) x 314.5 (h) x 50 (d) (6.7" x 12.4" x 2")
Pendant Weight	.998 kg (2.2 lbs)
Interface	One Compact Flash slot; One USB port (1.1)
Pendant Playback Buttons	Teach/Play/Remote Keypress selector Servo On, Start, Hold, and Emergency Stop Buttons
Programming Language	INFORM III, menu-driven programming
Maintenance Functions	Displays troubleshooting for alarms, predicts reducer wear
Number of Robots/Axes	Up to 8 robots, 72 axes
Multi Tasking	Up to 16 concurrent jobs, 4 system jobs
Fieldbus	DeviceNet Master/Slave, AB RIO, Profibus, Interbus-S, M-Net, CC Link, EtherNet IP/Slave
Ethernet	10 Base T/100 Base TX
Safety	Dual-channel Emergency Stop Pushbuttons, 3-position Enable Switch, Manual Brake Release Meets ANSI/RIA R15.06-1999, ANSI/RIA/ISO 10218-1-2007 and CSA Z434-03

**See DX100 Controller data sheet (DS-399) for complete specifications

www.motoman.com

MOTOMAN ROBOTICS
100 AUTOMATION WAY, MIAMISBURG, OHIO 45342
TEL: 937.847.6200 ■ FAX: 937.847.6277

YASKAWA
MOTOMAN ROBOTICS

TECHNICAL SPECIFICATIONS SUBJECT TO CHANGE WITHOUT NOTICE
DS-407-F ©2012 YASKAWA AMERICA, INC. FEBRUARY 2012

MOTOMAN IS A REGISTERED TRADEMARK
WINDOWS IS A REGISTERED TRADEMARK OF MICROSOFT
ALL OTHER MARKS ARE THE TRADEMARKS AND
REGISTERED TRADEMARKS OF YASKAWA AMERICA, INC.