

MATERIAL HANDLING

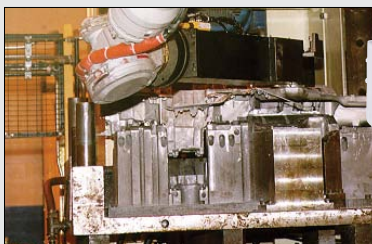

DIE CAST MACHINE EXTRACTION



"JIGLESS" FIXTURING



HP500D

HP600D

DIE CAST HANDLING • MACHINE TENDING • MATERIAL HANDLING • PRESS TENDING

Payloads:

500 kg (HP500D)
600 kg (HP600D)

Powerful, Flexible and Reliable

- Powerful heavy-payload robots provide flexibility and superior performance in material handling, machine tending and die cast/investment casting applications.
- Ideal for "jigless" applications where robot positions part for processing by other robots or two robots handle a single part.
- Hefty 500-kg (1,102.5-lb) payload (HP500D) and 600-kg (1,323-lb) payload (HP600D) robots provide versatility with heavy loads.
- Full six-axis capability with parallel-link construction for strength, rigidity and stabilization of high moment/inertia loads. Heavy-duty bearings provide smooth arm rotation.
- HP500D and HP600D robots: 2,542 mm (100.1") horizontal reach; 2,761 mm (108.7") vertical reach. Both models have ± 0.5 mm (± 0.02 ") repeatability.
- Fast axial speeds and acceleration reduce cycle times and increase production output.

- Large work envelope accommodates a wide range of big, heavy parts.
- Streamlined design allows robot to reach into confined spaces, improving system productivity.

DX100 Controller

- Patented multiple robot control supports up to 8 robots/72 axes.
- Windows® CE programming pendant with color touch screen and USB interface.
- Faster processing speeds for smoother interpolation. Quicker I/O response. Accelerated Ethernet communication.
- Extensive I/O suite includes integral PLC and touch screen HMI, 2,048 I/O and graphical ladder editor.
- Supports all major fieldbus networks, including EtherNet/IP, DeviceNet, Profibus-DP and many others.
- Compliant to ANSI/RIA R15.06-1999 and other relevant ISO and CSA safety standards. Optional Category 3 functional safety unit.

TOP REASONS TO BUY

- Full 6-axis capability provides high flexibility
- Ideal for heavy part handling and "jigless" processing
- IP67 wrist rating
- Outstanding reliability

HP500D/HP600D ROBOTS

HP500D robot shown.
All dimensions are metric (mm) and for reference only. Please request detail drawings for all design/engineering requirements.

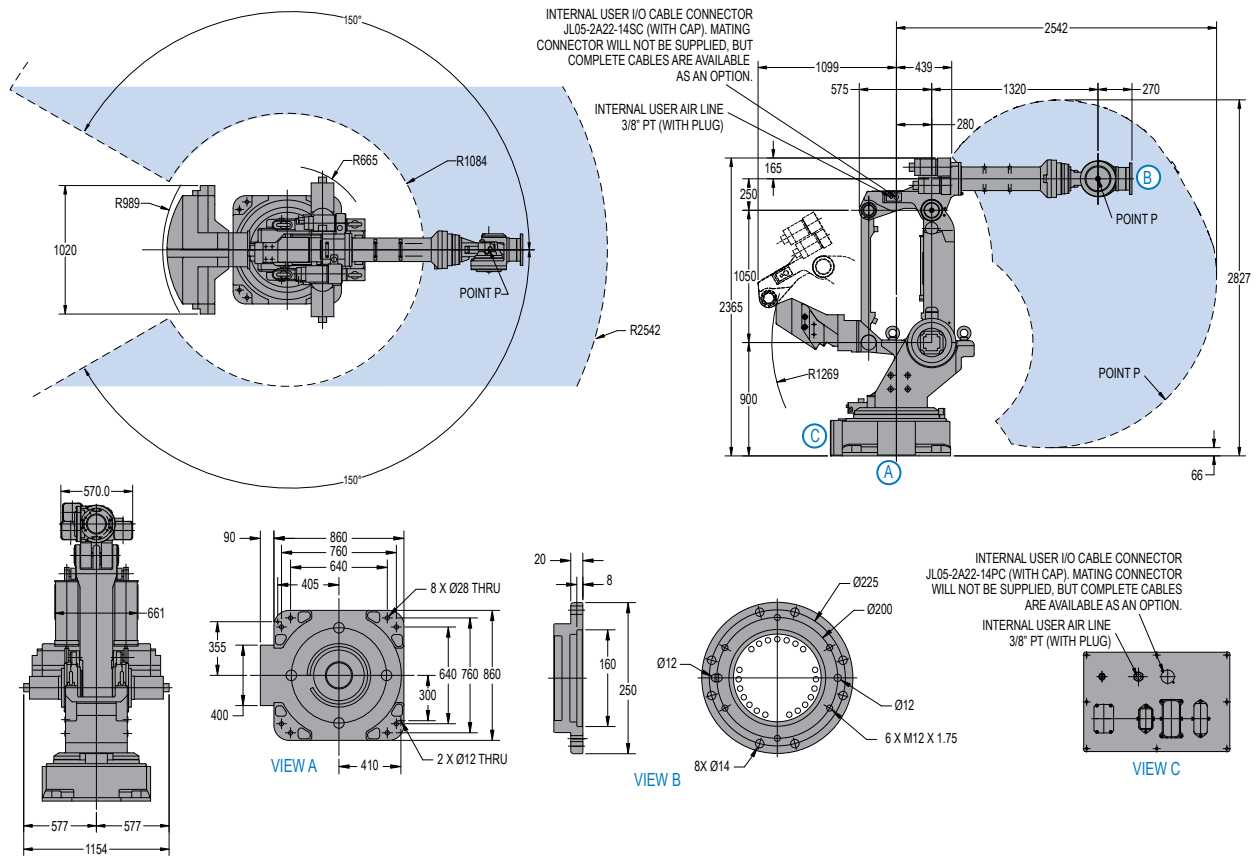

ROBOT SPECIFICATIONS

		HP500D	HP600D
Structure		Articulated	Articulated
Controlled Axes		6	6
Payload		500 kg (1,102.5 lbs)	600 kg (1,323 lbs)
Vertical Reach		2,761 mm (108.7")	2,761 mm (108.7")
Horizontal Reach		2,542 mm (100.1")	2,542 mm (100.1")
Repeatability		±0.5 mm (±0.02")	±0.5 mm (±0.02")
Maximum Motion Range	S-Axis (Turning/Sweep)	±150°	±150°
	L-Axis (Lower Arm)	+61°/-55°	+61°/-55°
	U-Axis (Upper Arm)	+30°/-113°	+30°/-113°
	R-Axis (Wrist Roll)	±360°	±360°
	B-Axis (Bend/Pitch/Yaw)	±125°	±125°
	T-Axis (Wrist Twist)	±360°	±360°
Maximum Speed	S-Axis	80°/s	60°/s
	L-Axis	80°/s	70°/s
	U-Axis	80°/s	70°/s
	R-Axis	100°/s	80°/s
	B-Axis	100°/s	80°/s
	T-Axis	160°/s	160°/s
Approximate Mass		2,350 kg (5,181.8 lbs)	2,400 kg (5,292 lbs)
Brakes		All axes	All axes
Power Consumption		10 kVA	13 kVA
Allowable Moment	R-Axis	1,960 N • m	2,450 N • m
	B-Axis	1,960 N • m	2,450 N • m
	T-Axis	823 N • m	823 N • m
Allowable Moment of Inertia	R-Axis	150 kg • m ²	200 kg • m ²
	B-Axis	150 kg • m ²	200 kg • m ²
	T-Axis	90 kg • m ²	90 kg • m ²
Internal User I/O Cable		17 conductors + ground	17 conductors + ground
Internal User Air Line		1 – 3/8" PT connection	1 – 3/8" PT connection

DX100 CONTROLLER SPECIFICATIONS**

Dimensions (mm)	800 (w) x 1,000 (h) x 650 (d) (31.5" x 39.4" x 25.6")
Approximate Mass	250 kg max. (551.3 lbs)
Cooling System	Indirect cooling
Ambient Temperature	During operation: 0° to 45° C (32° to 113° F) During transit and storage: -10° to 60° C (14° to 140° F)
Relative Humidity	90% max. non-condensing
Primary Power Requirements	3-phase, 240/480/575 VAC at 50/60 Hz
Digital I/O	Standard I/O: 40 inputs/40 outputs consisting of 16 system inputs/16 system outputs, 24 user inputs/24 user outputs 32 Transistor Outputs: 8 Relay Outputs Max. I/O (optional): 2,048 inputs and 2,048 outputs
Position Feedback	By absolute encoder
Program Memory	JOB: 200,000 steps, 10,000 instructions CIO Ladder Standard: 15,000 steps Expanded: 20,000 steps
Pendant Dim. (mm)	169 (w) x 314.5 (h) x 50 (d) (6.7" x 12.4" x 2")
Pendant Weight	.998 kg (2.2 lbs)
Interface	One Compact Flash slot; One USB port (1.1)
Pendant Playback Buttons	Teach/Play/Remote Keyswitch selector Servo On, Start, Hold, and Emergency Stop Buttons
Programming Language	INFORM III, menu-driven programming
Maintenance Functions	Displays troubleshooting for alarms, predicts reducer wear
Number of Robots/Axes	Up to 8 robots, 72 axes
Multi Tasking	Up to 16 concurrent jobs, 4 system jobs
Fieldbus	DeviceNet Master/Slave, AB RIO, Profibus, Interbus-S, M-Net, CC Link, EtherNet IP/Slave
Ethernet	10 Base T/100 Base TX
Safety	Dual-channel Emergency Stop Pushbuttons, 3-position Enable Switch, Manual Brake Release Meets ANSI/RIA R15.06-1999, ANSI/RIA/ISO 10218-1-2007 and CSA Z434-03

**See DX100 Controller data sheet (DS-399) for complete specifications

www.motoman.com

MOTOMAN ROBOTICS
100 AUTOMATION WAY, MIAMISBURG, OHIO 45342
TEL: 937.847.6200 ■ FAX: 937.847.6277

YASKAWA

MOTOMAN ROBOTICS

TECHNICAL SPECIFICATIONS SUBJECT TO CHANGE WITHOUT NOTICE
DS-426-E ©2012 YASKAWA AMERICA, INC. JANUARY 2012

MOTOMAN IS A REGISTERED TRADEMARK
WINDOWS IS A REGISTERED TRADEMARK OF MICROSOFT
ALL OTHER MARKS ARE THE TRADEMARKS AND
REGISTERED TRADEMARKS OF YASKAWA AMERICA, INC.