

PENDANT LADDER EDITOR

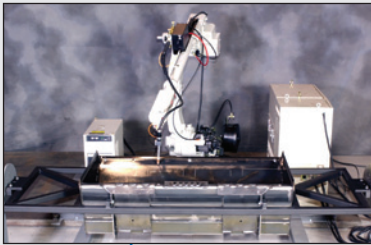

LARGE PART PROCESSING



MOTOSIM EG-VRC (OPTION)



MH50-20

ARC WELDING • COATING • DISPENSING • MACHINE TENDING
MATERIAL CUTTING • MATERIAL HANDLING • PRESS TENDING

Payload: 20 kg

TOP REASONS TO BUY

- Longer-reach robot specifically designed for processing large parts
- Multiple robot control (up to eight robots/72 axes) simplifies programming
- Highest axis speeds in its class
- Extremely flexible design allows a single robot to be used for welding, coating, dispensing, material cutting and material handling
- Improved wrist moment and inertia ratings for a wider range of applications

Long/Extended Reach for Large Parts

- Powerful, high-speed robot with long reach offers superior performance in arc welding, coating, dispensing, material cutting and handling applications.
- 20 kg (44.1 lb) payload; 3,106 mm (122.3") horizontal reach; 5,585 mm (219.9") vertical reach; ± 0.15 mm (± 0.006 ") repeatability.
- Ideal for processing large parts. In many cell layouts, a long/extended reach robot can eliminate the need for an external track, reducing system cost and simplifying programming.
- Can be floor-, wall-, or ceiling-mounted to provide layout flexibility. Brakes on all axes.
- Wide work envelope with small interference zone, allows robot to be placed close to workpieces/equipment.

DX100 Controller

- Patented multiple robot control supports up to 8 robots/72 axes.
- Windows® CE programming pendant with color touch screen and USB interface.
- Faster processing speeds for smoother interpolation. Quicker I/O response. Accelerated Ethernet communication.
- Extensive I/O suite includes integral PLC and touch screen HMI, 2,048 I/O and graphical ladder editor.
- Supports all major fieldbus networks, including EtherNet/IP, DeviceNet, Profibus-DP and many others.
- Compliant to ANSI/RIA R15.06-1999 and other relevant ISO and CSA safety standards. Optional Category 3 functional safety unit.

MH50-20 ROBOT

All dimensions are metric (mm) and for reference only. Please request detail drawings for all design/engineering requirements.

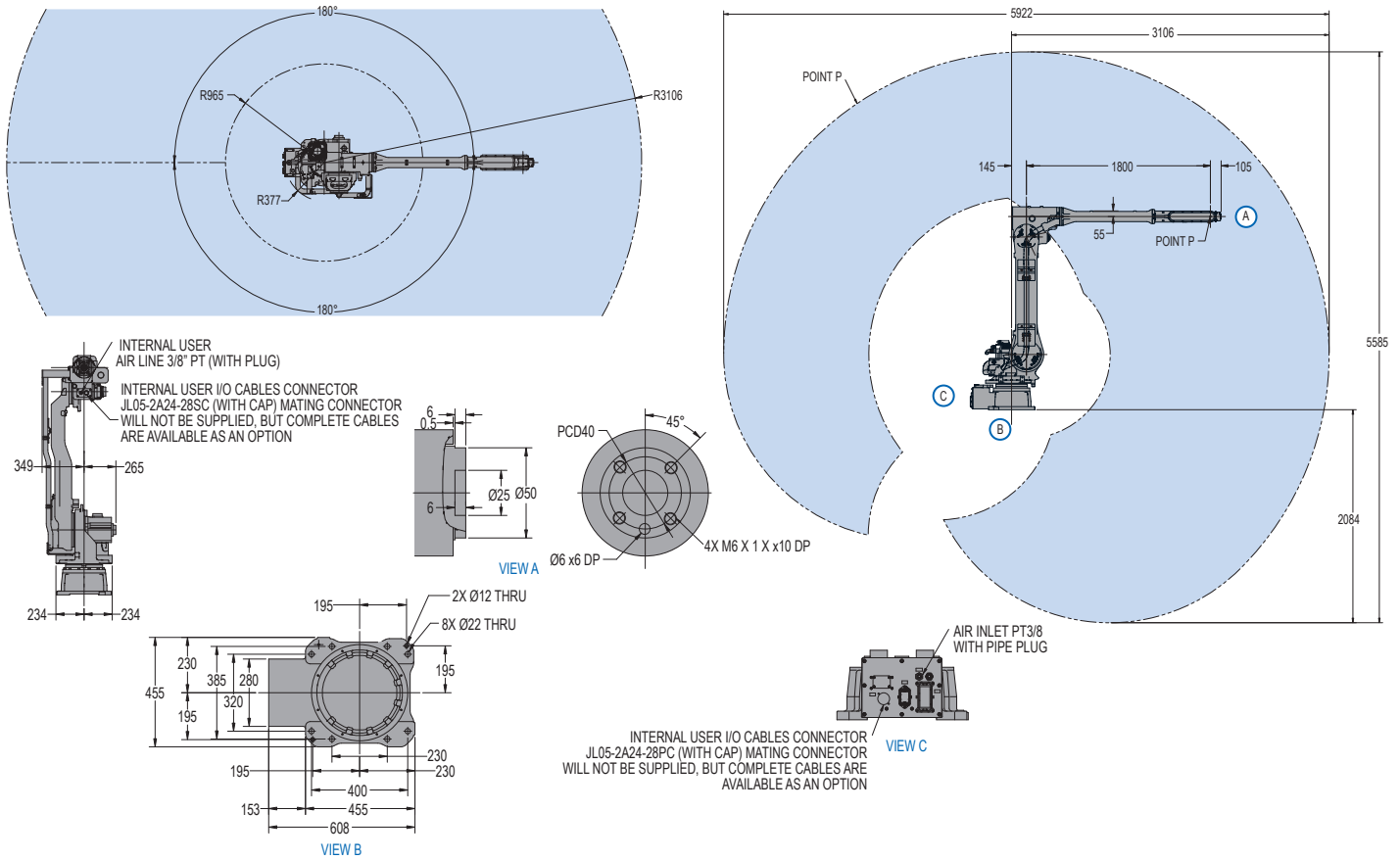

MH50-20 SPECIFICATIONS

Structure	Vertical jointed-arm type	
Controlled Axes	6	
Payload	20 kg (44.1 lbs)	
Vertical Reach	5,585 mm (219.9")	
Horizontal Reach	3,106 mm (122.39")	
Repeatability	±0.15 mm (±0.006")	
Maximum Motion Range	S-Axis (Turning/Sweep) L-Axis (Lower Arm) U-Axis (Upper Arm) R-Axis (Wrist Roll) B-Axis (Bend/Pitch/Yaw) T-Axis (Wrist Twist)	±180° +135°/-90° +251°/-160° ±190° +230°/-50° ±360°
Maximum Speed	S-Axis L-Axis U-Axis R-Axis B-Axis T-Axis	180°/s 178°/s 178°/s 400°/s 400°/s 600°/s
Approximate Mass	495 kg (1,091.5 lbs)	
Brakes	All axes	
Power Consumption	3.5 kVA	
Allowable Moment	R-Axis B-Axis T-Axis	39.2 N • m 39.2 N • m 19.6 N • m
Allowable Moment of Inertia	R-Axis B-Axis T-Axis	1.05 kg • m ² 1.05 kg • m ² 0.75 kg • m ²
Internal User I/O Cable	23 conductors + ground	
Internal User Air Line	3/8" pipe tap connection	

DX100 CONTROLLER SPECIFICATIONS**

Dimensions (mm)	800 (w) x 1,000 (h) x 650 (d) (31.5" x 39.4" x 25.6")
Approximate Mass	250 kg max. (551.3 lbs)
Cooling System	Indirect cooling
Ambient Temperature	During operation: 0° to 45° C (32° to 113° F) During transit and storage: -10° to 60° C (14° to 140° F)
Relative Humidity	90% max. non-condensing
Primary Power Requirements	3-phase, 240/480/575 VAC at 50/60 Hz
Digital I/O	Standard I/O: 40 inputs/40 outputs consisting of 16 system inputs/ 16 system outputs, 24 user inputs/24 user outputs 32 Transistor Outputs; 8 Relay Outputs Max. I/O (optional): 2,048 inputs and 2,048 outputs
Position Feedback	By absolute encoder
Program Memory	JOB: 200,000 steps, 10,000 instructions CIO Ladder Standard: 15,000 steps Expanded: 20,000 steps
Pendant Dim. (mm)	169 (w) x 314.5 (h) x 50 (d) (6.7" x 12.4" x 2")
Pendant Weight	.998 kg (2.2 lbs)
Interface	One Compact Flash slot; One USB port (1.1)
Pendant Playback Buttons	Teach/Play/Remote Keyswitch selector Servo On, Start, Hold, and Emergency Stop Buttons
Programming Language	INFORM III, menu-driven programming
Maintenance Functions	Displays troubleshooting for alarms, predicts reducer wear
Number of Robots/Axes	Up to 8 robots, 72 axes
Multi Tasking	Up to 16 concurrent jobs, 4 system jobs
Fieldbus	DeviceNet Master/Slave, AB RIO, Profibus, Interbus-S, M-Net, CC Link, EtherNet IP/Slave
Ethernet	10 Base T/100 Base TX
Safety	Dual-channel Emergency Stop Pushbuttons, 3-position Enable Switch, Manual Brake Release Meets ANSI/RIA R15.06-1999, ANSI/RIA/ISO 10218-1-2007 and CSA Z434-03

**See DX100 Controller data sheet (DS-399) for complete specifications

www.motoman.com

YASKAWA

MOTOMAN ROBOTICS

MOTOMAN ROBOTICS
100 AUTOMATION WAY, MIAMISBURG, OHIO 45342
TEL: 937.847.6200 ■ FAX: 937.847.6277

TECHNICAL SPECIFICATIONS SUBJECT TO CHANGE WITHOUT NOTICE
DS-401-F ©2012 YASKAWA AMERICA, INC. FEBRUARY 2012

MOTOMAN IS A REGISTERED TRADEMARK
WINDOWS IS A REGISTERED TRADEMARK OF MICROSOFT
ALL OTHER MARKS ARE THE TRADEMARKS AND
REGISTERED TRADEMARKS OF YASKAWA AMERICA, INC.