

THRU-ARM CABLE MANAGEMENT



BAG PALLETIZING



CASE PALLETIZING

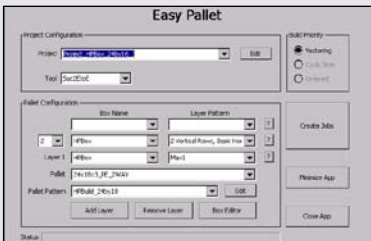

EASYPALLET PENDANT (OPTION)

TOP REASONS TO BUY

- High-performance robot maximizes productivity
- Internally routed air lines and wiring through all robot axes provides maximum system reliability
- Palletizes trailer height loads for many situations
- Gripper control by DeviceNet available as an option



MPL160

• PALLETIZING •

Payload: 160 kg

Flexible Palletizing Solution

- Four-axis MPL160 “Master Palletizing” robot has fast axial speeds and acceleration which reduces cycle times and increases production output.
- Extensive 3,024 mm (119.1”) vertical reach provides for palletizing loads up to 108” (2,743.2 mm) high on a 42” (1,066.8 mm) pallet, or up to 105” (2,667 mm) on a 48” (1,219.2 mm) pallet.
- 160 kg (352.8 lb) payload; 3,159 mm (124.4”) horizontal reach; ±0.5 mm (±0.02”) repeatability. Other MPL-series available with 80-, 100-, 300-, 500- and 800-kg payloads to meet wide range of palletizing requirements.
- Features internally routed air lines and wiring between base of robot and end-of-arm tool. Hollow wrist provides wide range of wrist motion and maximum cable life.
- Can service multiple infeed conveyors and up to four pallet build locations.
- Optional MotoSim® EG-VRC, off-line programming software with virtual robot control simplifies programming and simulation.
- Optional MotoPallet™ EG is a PC-based palletizing software that works with MotoSim EG simulation software to simplify off-line creation of robot palletizing patterns.

EasyPallet Pendant

- Motoman Robotics’ EasyPallet™ Pendant (option) makes programming complex pallet patterns quick and easy.
- With just a few simple menu selections, operators can choose from one of EasyPallet Pendant’s more than 200 pre-designed palletizing patterns – right from the robot teach pendant.
- Patterns are independent of box sizes. This allows a box size to be applied to any stacking pattern to create a unique layer configuration.
- Patterns adjust automatically to changing box and pallet sizes, in effect multiplying the number of available patterns available.

DX100 Controller

- Patented multiple robot control supports up to 8 robots/72 axes.
- Windows® CE programming pendant with color touch screen and USB interface.
- Faster processing speeds for smoother interpolation. Quicker I/O response. Accelerated Ethernet communication.
- Extensive I/O suite includes integral PLC and touch screen HMI, 2,048 I/O and graphical ladder editor.
- Supports all major fieldbus networks, including EtherNet/IP, DeviceNet, Profibus-DP and many others.
- Compliant to ANSI/RIA R15.06-1999 and other relevant ISO and CSA safety standards. Optional Category 3 functional safety unit.

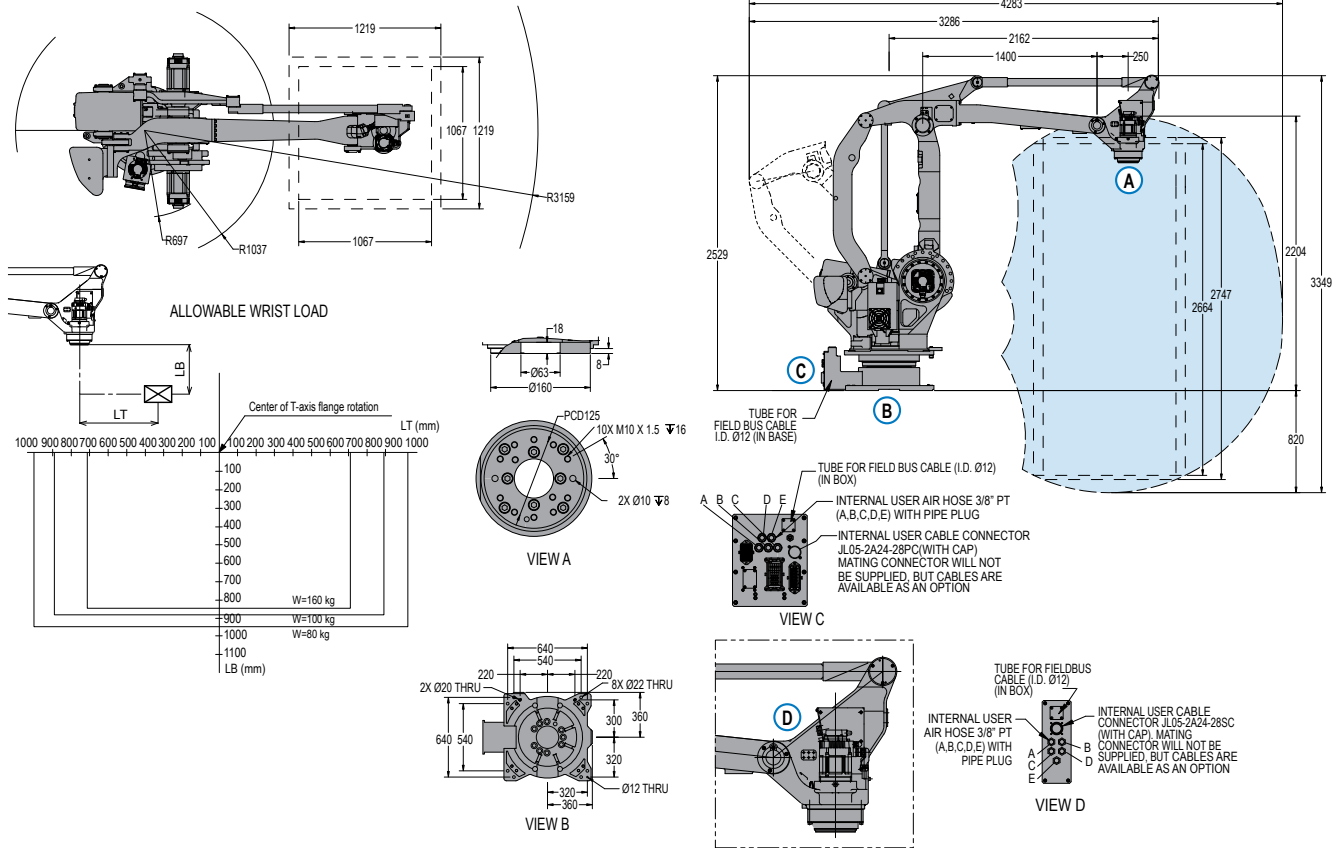

MPL160 SPECIFICATIONS

Structure	Vertical articulated type	
Controlled Axes	4	
Payload	160 kg (352.8 lbs)	
Vertical Reach	3,024 mm (119.1")	
Horizontal Reach	3,159 mm (124.4")	
Repeatability	± 0.5 mm (0.02")	
Maximum Motion Range	S-Axis (Turning/Sweep)	$\pm 180^\circ$
	L-Axis (Lower Arm)	$+90^\circ/-45^\circ$
	U-Axis (Upper Arm)	$+15.5^\circ/-120^\circ$
	T-Axis (Wrist Twist)	$\pm 360^\circ$
Maximum Speed	S-Axis	140°/s
	L-Axis	136°/s
	U-Axis	136°/s
	T-Axis	305°/s
Approximate Mass	1,700 kg (3,748.5 lbs)	
Brakes	All axes	
Power Consumption	9.5 kVA	
T-Axis Allowable Inertia	80 kg · m ²	
Internal User Electrical Cable	23 conductors + ground	
Internal User Air Hose	5 - 3/8" PT connectors	
Fieldbus Cable Tube To Upper Arm	Yes	

DX100 CONTROLLER SPECIFICATIONS**

Dimensions (mm)	800 (w) x 1,000 (h) x 650 (d) (31.5" x 39.4" x 25.6")
Approximate Mass	250 kg max. (551.3 lbs)
Cooling System	Indirect cooling
Ambient Temperature	During operation: 0° to 45° C (32° to 113° F) During transit and storage: -10° to 60° C (14° to 140° F)
Relative Humidity	90% max. non-condensing
Primary Power Requirements	3-phase, 240/480/575 VAC at 50/60 Hz
Digital I/O	Standard I/O: 40 inputs/40 outputs consisting of 16 system inputs/16 system outputs, 24 user inputs/24 user outputs 32 Transistor Outputs; 8 Relay Outputs Max. I/O (optional): 2,048 inputs and 2,048 outputs
Position Feedback	By absolute encoder
Program Memory	JOB: 200,000 steps, 10,000 instructions CIO Ladder Standard: 15,000 steps Expanded: 20,000 steps
Pendant Dim. (mm)	169 (w) x 314.5 (h) x 50 (d) (6.7" x 12.4" x 2")
Pendant Weight	.998 kg (2.2 lbs)
Interface	One Compact Flash slot; One USB port (1.1)
Pendant Playback Buttons	Teach/Play/Remote Keyswitch selector Servo On, Start, Hold, and Emergency Stop Buttons
Programming Language	INFORM III, menu-driven programming
Maintenance Functions	Displays troubleshooting for alarms, predicts reducer wear
Number of Robots/Axes	Up to 8 robots, 72 axes
Multi Tasking	Up to 16 concurrent jobs, 4 system jobs
Fieldbus	DeviceNet Master/Slave, AB RIO, Profibus, Interbus-S, M-Net, CC Link, EtherNet IP/Slave
Ethernet	10 Base T/100 Base TX
Safety	Dual-channel Emergency Stop Pushbuttons, 3-position Enable Switch, Manual Brake Release Meets ANSI/RIA R15.06-1999, ANSI/RIA/ISO 10218-1-2007 and CSA Z434-03

**See DX100 Controller data sheet (DS-399) for complete specifications