

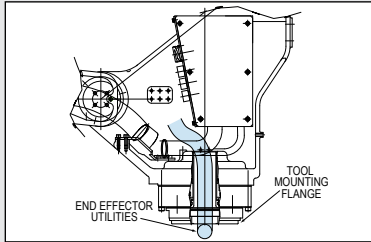

# MPL500

• PALLETIZING •

**Payload: 500 kg**



THRU-ARM CABLE MANAGEMENT

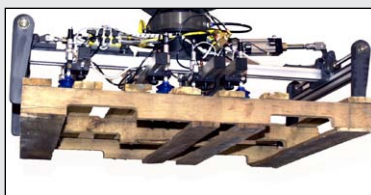

PALLET HANDLING



LAYER HANDLING

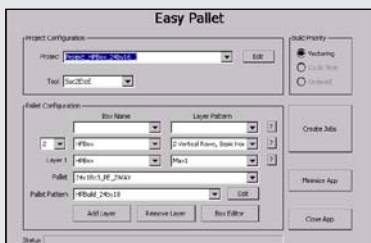

EASYPALLET PENDANT (OPTION)

## TOP REASONS TO BUY

- High-performance robot maximizes productivity in layer handling applications
- Internally routed air lines and wiring through all robot axes provides maximum system reliability
- Palletizes trailer height loads
- Gripper control by DeviceNet available as an option

## Flexible Palletizing Solution

- Four-axis MPL500 “Master Palletizing” robot features fast axial speeds and acceleration to reduce cycle times and increase production output.
- Extensive 3,024 mm (119.1”) vertical reach provides for palletizing loads up to 108” (2,747 mm) high on a 42” (1,067 mm) pallet, or up to 105” (2,664 mm) on a 48” (1,219 mm) pallet.
- 500 kg (1,105.2 lb) payload; 3,159 mm (124.4”) horizontal reach;  $\pm 0.5$  mm ( $\pm 0.02$ ”) repeatability. Other MPL-series available with 80-, 100-, 160-, 300- and 800-kg payloads to meet wide range of palletizing requirements.
- Features internally routed air lines and wiring between base of robot and end-of-arm tool. Hollow wrist provides wide range of wrist motion and maximum cable life.
- Can service multiple infeed conveyors and up to four pallet build locations.
- Optional MotoSim® EG-VRC, off-line programming software with virtual robot control simplifies programming and simulation.
- Optional MotoPallet™ EG is a PC-based palletizing software that works with MotoSim EG simulation software to simplify off-line creation of robot palletizing patterns.

## EasyPallet Pendant

- Motoman Robotics’ EasyPallet™ Pendant (option) makes programming complex pallet patterns quick and easy.
- With just a few simple menu selections, operators can choose from one of EasyPallet Pendant’s more than 200 pre-designed palletizing patterns – right from the robot teach pendant.
- Patterns are independent of box sizes. This allows a box size to be applied to any stacking pattern to create a unique layer configuration.
- Patterns adjust automatically to changing box and pallet sizes, in effect multiplying the number of patterns available.

## DX100 Controller

- Patented multiple robot control supports up to 8 robots/72 axes.
- Windows® CE programming pendant with color touch screen and USB interface.
- Faster processing speeds for smoother interpolation. Quicker I/O response. Accelerated Ethernet communication.
- Extensive I/O suite includes integral PLC and touch screen HMI, 2,048 I/O and graphical ladder editor.
- Supports all major fieldbus networks, including EtherNet/IP, DeviceNet, Profibus-DP and many others.
- Compliant to ANSI/RIA R15.06-1999 and other relevant ISO and CSA safety standards. Optional Category 3 functional safety unit.

# MPL500 ROBOT

All dimensions are metric (mm) and for reference only. Please request detail drawings for all design/engineering requirements.

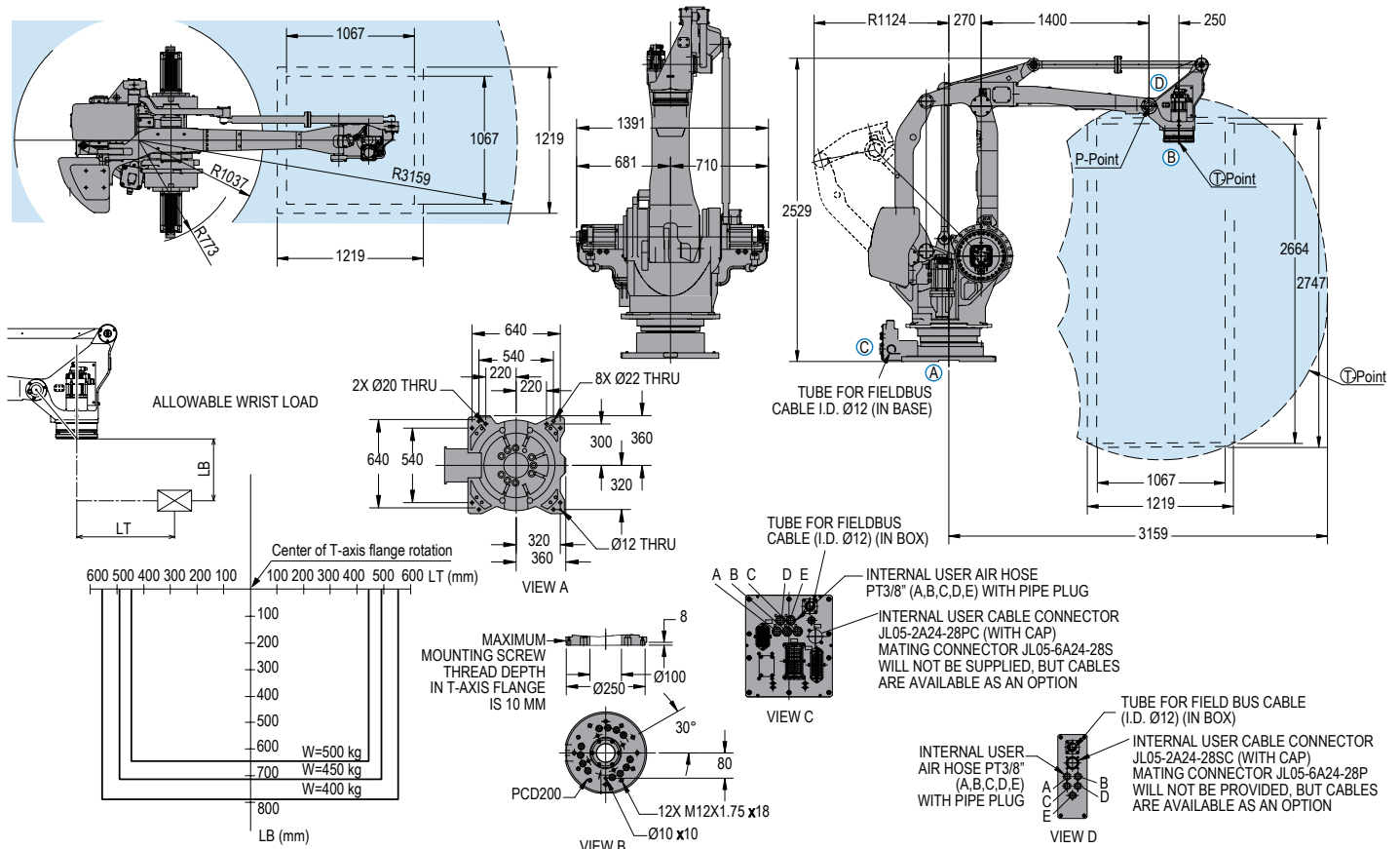

## MPL500 SPECIFICATIONS

<b>Structure</b>	Vertical articulated type
<b>Controlled Axes</b>	4
<b>Payload</b>	500 kg (1,102.5 lbs)
<b>Vertical Reach</b>	3,024 mm (119.1")
<b>Horizontal Reach</b>	3,159 mm (124.4")
<b>Repeatability</b>	±0.5 mm (0.02")
<b>Maximum Motion Range</b>	S-Axis (Turning/Sweep) ±180° L-Axis (Lower Arm) +90°/-45° U-Axis (Upper Arm) +15.5°/-120° T-Axis (Wrist Twist) ±360°
<b>Maximum Speed</b>	S-Axis 85°/s L-Axis 85°/s U-Axis 85°/s T-Axis 195°/s
<b>Approximate Mass</b>	2,300 kg (5,071.5 lbs)
<b>Brakes</b>	All axes
<b>Power Consumption</b>	9.5 kVA
<b>T-Axis Allowable Inertia</b>	200 kg · m <sup>2</sup>
<b>Internal User Electrical Cable</b>	23 conductors + ground
<b>Internal User Air Hose</b>	5 - 3/8" PT connectors
<b>Fieldbus Cable Tube To Upper Arm</b>	Yes

## DX100 CONTROLLER SPECIFICATIONS\*\*

<b>Dimensions (mm)</b>	800 (w) x 1,000 (h) x 650 (d) (31.5" x 39.4" x 25.6")
<b>Approximate Mass</b>	250 kg max. (551.3 lbs)
<b>Cooling System</b>	Indirect cooling
<b>Ambient Temperature</b>	During operation: 0° to 45° C (32° to 113° F) During transit and storage: -10° to 60° C (14° to 140° F)
<b>Relative Humidity</b>	90% max. non-condensing
<b>Primary Power Requirements</b>	3-phase, 240/480/575 VAC at 50/60 Hz
<b>Digital I/O</b>	Standard I/O: 40 inputs/40 outputs consisting of 16 system inputs/16 system outputs, 24 user inputs/24 user outputs 32 Transistor Outputs; 8 Relay Outputs Max. I/O (optional): 2,048 inputs and 2,048 outputs
<b>Position Feedback</b>	By absolute encoder
<b>Program Memory</b>	JOB: 200,000 steps, 10,000 instructions CIO Ladder Standard: 15,000 steps Expanded: 20,000 steps
<b>Pendant Dim. (mm)</b>	169 (w) x 314.5 (h) x 50 (d) (6.7" x 12.4" x 2")
<b>Pendant Weight</b>	.998 kg (2.2 lbs)
<b>Interface</b>	One Compact Flash slot; One USB port (1.1)
<b>Pendant Playback Buttons</b>	Teach/Play/Remote Keyswitch selector Servo On, Start, Hold, and Emergency Stop Buttons
<b>Programming Language</b>	INFORM III, menu-driven programming
<b>Maintenance Functions</b>	Displays troubleshooting for alarms, predicts reducer wear
<b>Number of Robots/Axes</b>	Up to 8 robots, 72 axes
<b>Multi Tasking</b>	Up to 16 concurrent jobs, 4 system jobs
<b>Fieldbus</b>	DeviceNet Master/Slave, AB RIO, Profibus, Interbus-S, M-Net, CC Link, EtherNet IP/Slave
<b>Ethernet</b>	10 Base T/100 Base TX
<b>Safety</b>	Dual-channel Emergency Stop Pushbuttons, 3-position Enable Switch, Manual Brake Release Meets ANSI/RIAR15.06-1999, ANSI/RIA/ISO 10218-1-2007 and CSA Z434-03

\*\*See DX100 Controller data sheet (DS-399) for complete specifications

www.motoman.com

MOTOMAN ROBOTICS  
100 AUTOMATION WAY, MIAMISBURG, OHIO 45342  
TEL: 937.847.6200 ■ FAX: 937.847.6277

**YASKAWA**  
MOTOMAN ROBOTICS

TECHNICAL SPECIFICATIONS SUBJECT TO CHANGE WITHOUT NOTICE  
DS-439-B ©2011 YASKAWA AMERICA, INC. JUNE 2011

MOTOMAN IS A REGISTERED TRADEMARK  
WINDOWS IS A REGISTERED TRADEMARK OF MICROSOFT  
ALL OTHER MARKS ARE THE TRADEMARKS AND  
REGISTERED TRADEMARKS OF YASKAWA AMERICA, INC.