

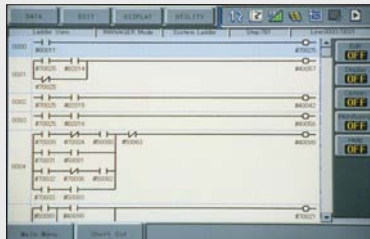

OPTIONAL CUSTOM HMI



MULTIPLE ROBOT CONTROL



LADDER EDITOR

## FEATURES & OPTIONS

- Patented multiple robot control capability (up to FOUR robots with one pendant)
- Windows® CE operating system on programming pendant
- Standard Ethernet communication
- Compliance with ANSI/RIA R15.06-1999 safety standard
- Unmatched memory: 60,000 steps (taught points), 10,000 ladder (concurrent I/O) instructions
- On-board graphical ladder editor
- Ability to fit up to three external axis servo amplifiers



*Motoman Robotics' NX100 robot controller offers high performance, open communication, and integrated cell control*

# NX100

—ROBOT CONTROLLER—

The revolutionary NX100 controller features a Windows® CE programming pendant with color touch screen, high-speed processing, unmatched memory (60,000 steps, 10,000 instructions), built-in Ethernet, and a robust PC architecture. The NX100 features password protection with four levels and up to 100 individual users.

The NX100 easily handles multiple tasks, with unmatched ability to control up to four robots (up to 36 axes, including robots and external axes), and I/O devices. Dynamic interference spheres protect the robot arm, providing collision avoidance/arm interference prevention. Advanced Robot Motion (ARM) control provides high-performance path accuracy and vibration control. In addition, the NX100 features best-in-class path planning that dramatically reduces teaching time.

The programming pendant features a unique cross-shaped navigation cursor that reduces teaching time by 30 percent. It has full-color touch-screen display and a convenient compact flash slot for easy

memory back-ups. All operator controls are located on the pendant, allowing the control cabinet to be mounted remotely.

Dual-channel safety features include enhanced E-Stop functionality, integrated speed monitoring, and manual brake release for the robot.

The NX100 also offers unmatched connectivity, highly flexible Fieldbus support, and easy connection to an information infrastructure through standard network options for DeviceNet, ControlNet, Profibus-DP, EtherNet/IP, and many others. An optional web server that allows remote monitoring and diagnosis is available.

By eliminating the need for a separate PLC, PC-based human machine interface (HMI), and separate password protection hardware, and by providing a standard Ethernet port, the NX100 delivers significant cost savings at the system level, while also decreasing system complexity and improving overall system reliability.

# NX100 Robot Controller

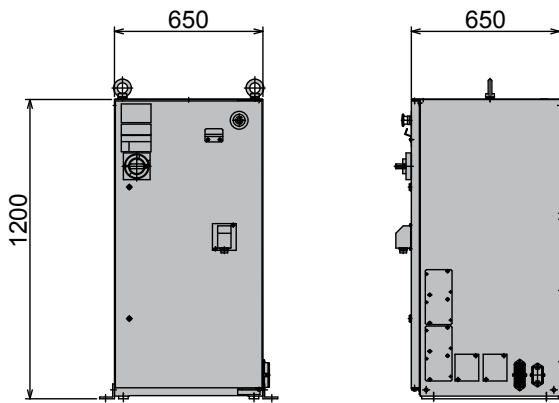

All dimensions are metric (mm) and for reference only.

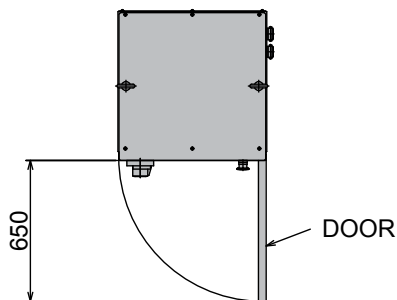

## NX100 ROBOT CONTROLLER SPECIFICATIONS

CONTROLLER	
Dimensions	650(w) x 1,200(h) x 650(d) mm (25.6" x 47.2" x 25.6")
Approximate Mass	150-250 kg (330.8-551.3 lbs.)
Cooling System	Indirect cooling
Ambient Temperature	During operation: 0° C (32° F) to 45° C (113° F) During transport and storage: -10° C (14° F) to +60° C (140° F)
Relative Humidity	90% max. non-condensing
Primary Power Requirements	3-phase, 240/480/575 VAC at 50/60 Hz
Digital I/O	Standard I/O: 40 inputs/40 outputs consisting of 16 system inputs/16 system outputs, 24 user inputs/24 user outputs NPN - Standard PNP - Optional Expandable to 1024 inputs/1024 outputs
Position Feedback	Absolute encoder
Program Memory	60,000 steps and 10,000 instructions
Interface	Ethernet, RS-232C
Multiple Robot Control	Dual, triple, and quad

SAFETY FEATURES	
Safety Specs	Dual-channel Emergency Stop Pushbuttons, 3-Position Enable Switch built into pendant, Manual Brake Release Meets ANSI/RIA R15.06-1999 safety standard
Collision Avoidance	Collision avoidance zones and radial interference zones
Collision Detection	Protects robot by monitoring torque levels on manipulator
Machine Lock	Permits testing of peripheral devices without robot operation
Safety Interlock	Prevents robot operation while safety circuit is open

PENDANT	
Pendant Dimensions	199 x 338 x 60 mm (7.8" x 13.3" x 2.4")
Pendant Display	6.5 inch full color touch screen, 640 x 480 (VGA)
Pendant Languages	English, German, Japanese, Spanish, Chinese
Pendant Weight	1.34 kg (2.96 lbs.)
Coordinate System	Joint, rectangular, cylindrical, tool, 24 user-coordinate frames
Windows® Menu-Driven Interface	User-selectable touch-screen menu Compact Flash slot for backup
Pendant O/S	Windows CE
Protection Rating	IP65

## Standard I/O - NPN

Forty optically isolated inputs, 32 transistor outputs, 8 relay contact outputs (configured to optimize each application), and four break-out cards are provided as standard. For arc welding applications, one XEW01 welder interface board is installed in the cabinet as standard.

## I/O Expansion

The NX100 supports I/O expansion via:

- Profibus-DP
- ControlNet
- Analog I/O
- DeviceNet
- Remote I/O
- Discrete I/O, NPN or PNP
- EtherNet/IP
- Other networks available

PROGRAMMING	
Programming Language	INFORM III, menu-driven programming
Robot Motion Control	Joint motion, linear, circular, spline interpolation
Speed Adjustment	Percentage of maximum for joint motion; mm/sec, cm/min, in/min for displacement; °/sec for orientation
Device Instructions	Application-specific (ARCON, ARCOFF, LASERON, LASEROFF, HANDON, HANDOFF)
I/O Instructions	Discrete I/O, 4-bit and 8-bit manipulation, analog output, analog input, analog scaling, sloping
Operation	Up to 5 levels of undo/redo

MAINTENANCE	
Maintenance Functions	System monitor, internal maintenance clocks
Self-Diagnostics	Classifies errors and major/minor alarms and displays data
User Alarm Display	Displays alarm messages for peripheral devices
Alarm Display	Alarm messages and alarm history
I/O Diagnosis	Permits simulated enabled/disabled input/output
TCP Calibration	Automatically calibrates parameters for end-effectors, optional TCP recovery function
Tool Weight Calibration	Automatically calibrates total weight of tool, center of gravity and inertia for peak performance

www.motoman.com



MOTOMAN ROBOTICS

MOTOMAN ROBOTICS  
100 AUTOMATION WAY, MIAMISBURG, OHIO 45342  
TEL: 937.847.6200 ■ FAX: 937.847.6277