



APPLIANCE PARTS



WRIST DETAIL



MOTOSIM® EG OFF-LINE PROGRAMMING

FEATURES & OPTIONS

- 798 mm reach
- ± 0.03 mm (± 0.001 ") repeatability
- Floor-, wall- or ceiling-mount options
- FM rating: Class 1, Div. 1 (explosion-proof)
- MotoSim® EG simulation software (optional)
- MotoMax® III warranty (standard)



Motoman's compact PX800 robot is the world's most space-efficient coating robot

• COATING • DISPENSING

PX800

Payload: 3 kg

Compact Coating Robot

The high-speed PX800 robot offers minimal footprint and superior performance in coating applications.

The compact, space-saving design of the PX800 robot makes it easy to mount on the floor, wall or ceiling. Its full six-axis capability ensures proper gun angles for painting small parts.

The PX800 robot is Factory Mutual (FM) approved for Class 1, Div. 1 use in hazardous environments. It features a 3 kg (6.6 lb) payload capacity, a 798 mm (31.4") reach, and a ± 0.03 mm (± 0.001 ") repeatability.

The PX800 robot delivers superior performance while minimizing cycle time and optimizing material usage. It is ideal for coating small electronic or appliance parts, as well as automotive components.

Advanced XRC 2001-FM Controller

The advanced XRC 2001-FM controller features fast processing, easy-to-use INFORM II programming language, and includes application-specific software for coating.

Two types of programming pendants are available – the standard model for use in non-explosive painting environments and as an option, an intrinsically-safe version for use in hazardous conditions.

The XRC 2001-FM coordinates operation of robot and coating devices, including the gun, to increase productivity by reducing over-spraying and the number of times the spray starts and stops. It supports gun control instructions such as spray start/stop and coating conditions.

The XRC 2001 supports standard networks (such as DeviceNet, ControlNet, Profibus-DP, and Interbus-S), enabling connection to paint machine controllers and line controllers.

PX800 ROBOT

All dimensions are metric (mm) and for reference only. Please request detail drawings for all design/engineering requirements.

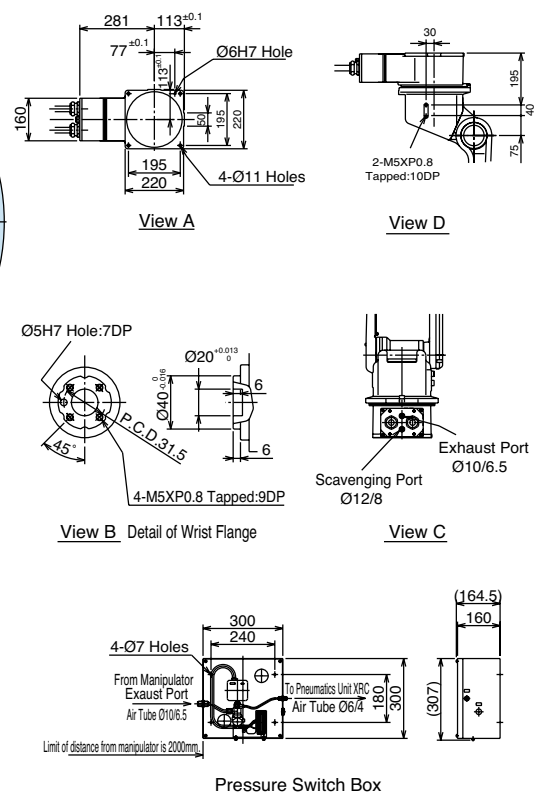
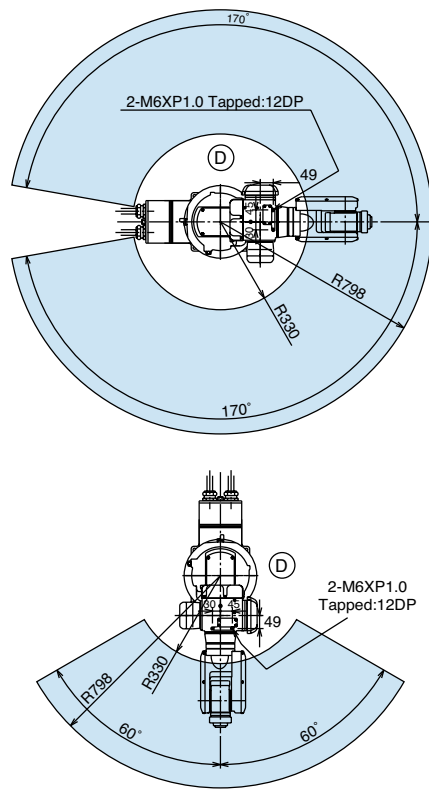
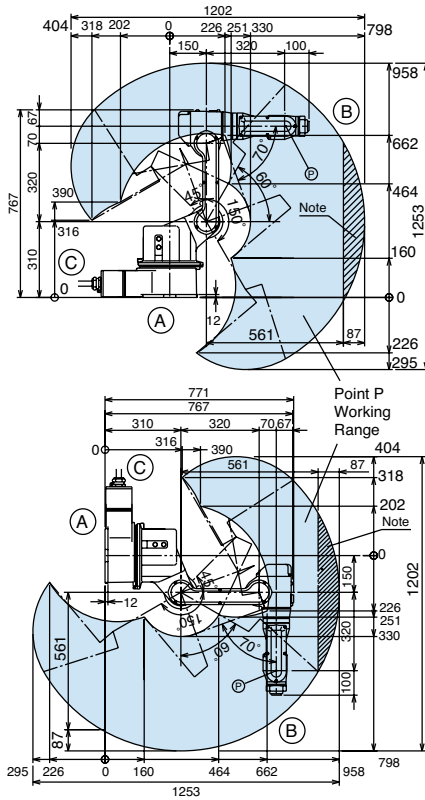

Note: A "servo alarm" error occurs if the manipulator is held in this position for a long period of time when the robot is wall-mounted.

PX800 SPECIFICATIONS

| | | |
|------------------------------------|---------------------------|--|
| Structure | Vertical jointed-arm type | |
| Controlled Axes | 6 | |
| Payload | 3 kg (6.6 lbs.) | |
| Vertical Reach | 1,253 mm (49.3") | |
| Horizontal Reach | 798 mm (31.4") | |
| Repeatability | ±0.03 mm (0.001") | |
| Maximum Motion Range | S-Axis (Turning/Sweep) | Wall mount: ±60° Floor/ceiling mount: ±170° |
| | L-Axis (Lower Arm) | +150°/-45° |
| | U-Axis (Upper Arm) | +190°/-70° |
| | R-Axis (Wrist Roll) | ±165° |
| | B-Axis (Bend/Pitch/Yaw) | ±135° |
| T-Axis (Wrist Twist) | ±350° | |
| Maximum Speed | S-Axis | 2.62 rad/s, 150°/s |
| | L-Axis | 2.09 rad/s, 120°/s |
| | U-Axis | 3.40 rad/s, 195°/s |
| | R-Axis | 5.23 rad/s, 300°/s |
| | B-Axis | 5.23 rad/s, 300°/s |
| T-Axis | 7.33 rad/s, 420°/s | |
| Approximate Mass | 42 kg (92.6 lbs.) | |
| Brakes | All Axes | |
| Power Consumption | 1.5 kVA | |
| Allowable Moment | R-Axis | 5.39 N · m |
| | B-Axis | 5.39 N · m |
| | T-Axis | 2.94 N · m |
| Allowable Moment of Inertia | R-Axis | 0.1 kg · m ² |
| | B-Axis | 0.1 kg · m ² |
| | T-Axis | 0.03 kg · m ² |
| Mounting | Floor, wall, ceiling | |

XRC 2001-FM CONTROLLER SPECIFICATIONS

| | |
|-----------------------------------|---|
| Structure | Free-standing, enclosed type |
| Dimensions (mm) | 750 (w) x 1,100 (h) x 550 (d) (29.5" x 43.3" x 21.7") |
| Approximate Mass | 70 kg (154.4 lbs) |
| Cooling System | Indirect cooling |
| Ambient Temperature | During operation: 0° C (32° F) to 45° C (113° F) During transmit and storage: -10° C (14° F) to +60° C (140° F) |
| Relative Humidity | 20 to 80% RH non-condensing (85% or less for pendant) |
| Primary Power Requirements | 3-phase, 200/220 VAC (+10% to -15%) at 50/60 Hz |
| Grounding | Grounding resistance: ≤100 ohms Separate ground required ≤10 ohms required for intrinsically-safe pendant |
| Digital I/O | Specialized signals (hardware): 12 inputs/2 outputs General signals (standard max): 40 inputs/40 outputs Expandable to 256 inputs/256 outputs |
| Position Feedback | By absolute encoder |
| Drive Units | Servo packs for AC servomotors |
| Accel/Decel | Software servo control |
| Program Memory | 5,000 steps and 3,000 instructions |
| Pendant Dim. (mm) | 200 (w) x 325 (h) x 77 (d) (7.9" x 12.8" x 3.0") |
| Pendant Buttons Provided | Teach Play, Remote, Servo On, Start, Hold, Emergency Stop, Edit Lock |
| Safety | Emergency Stop Pushbuttons, 3-position Deadman, Brake Release Switches Meets ANSI/RIA R15.06-1999 standard Factory Mutual approved, Class 1, Div. 1 |

www.motoman.com

MOTOMAN ROBOTICS
100 AUTOMATION WAY, MIAMISBURG, OHIO 45342
TEL: 937.847.6200 ■ FAX: 937.847.6277

YASKAWA

MOTOMAN ROBOTICS

TECHNICAL SPECIFICATIONS SUBJECT TO CHANGE WITHOUT NOTICE
DS-187-G ©2011 YASKAWA AMERICA, INC. JUNE 2011

MOTOMAN IS A REGISTERED TRADEMARK
WINDOWS IS A REGISTERED TRADEMARK OF MICROSOFT
ALL OTHER MARKS ARE THE TRADEMARKS AND
REGISTERED TRADEMARKS OF YASKAWA AMERICA, INC.