

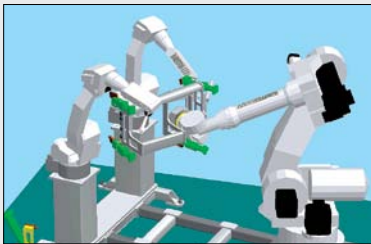

MULTIPLE ROBOT CONTROL

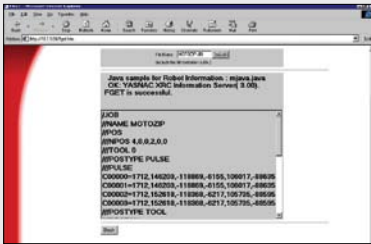

JIGLESS FIXTURING



MOTOVIEW (optional)

FEATURES & OPTIONS

- 32-bit RISC architecture and digital servo drives
- Patented multiple robot synchronous control
- Compliant with R15.06-1999 ANSI/RIA standard
- Manual brake release switch
- INFORM II language with icon-driven interface
- UL- and CSA-listed fusible disconnect switch, circuit breakers, circuit protectors, servo power conductors, and line filters



Motoman Robotics' XRC 2001 robot controller, offers flexibility, high performance, open communication, and award-winning ergonomic design

XRC 2001

ROBOT CONTROLLER



**GOOD DESIGN
AWARD 1998**

The XRC 2001 controller features factory-proven, advanced 32-bit RISC distributed architecture and digital servo drives. The RISC processor delivers higher performance than Pentium-based controllers.

The XRC 2001's safety circuitry features dual hardware architecture to meet the "control reliable" safety performance requirements of the ANSI/RIA 15.06-1999 standard.

An award-winning, lightweight, ergonomically designed programming pendant with a three-position safety switch simplifies programming. The pendant supports Windows®-like menus on a graphical 5.7-inch LED user interface with cross cursor keys. An RS-232C interface is provided for FC1/FC2/FDE communication.

Motoman Robotics' industry-leading INFORM II language is icon-driven and easy-to-use. Application-specific software include a powerful instructions set that simplifies programming.

The XRC 2001 features a patented method for programming and control of multiple robots (U.S. patent 5,889,924). It offers unmatched capability for control of up to four robots. The XRC 2001 features built-in collision avoidance, including a definition of the entire robot and its end-of-arm tool. Multiple robot control also minimizes cost and facilitates "jigless" processing – one robot conveys and positions parts for processing by up to three additional robots, all controlled by one XRC 2001 – providing the ultimate form of flexible automation.

XRC 2001 Robot Controller

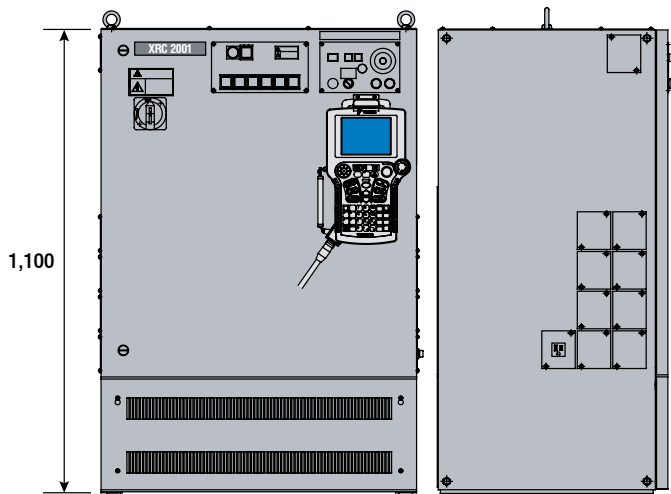

All dimensions are metric (mm) and for reference only.

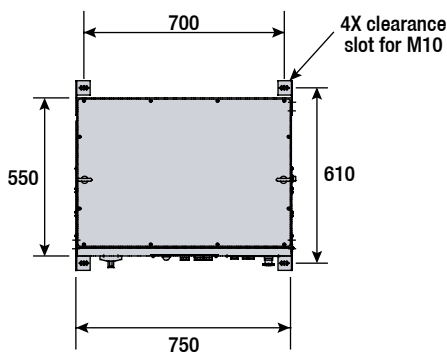

Standard I/O

Forty optically isolated inputs, 24 transistor outputs, 16 relay contact outputs (configured as dedicated I/O in order to optimize each application), and four break-out cards are provided as standard. For arc welding applications, one XEW01 welder interface board is installed in the cabinet as standard.

I/O Expansion

The discrete I/O expansion board XOI01, the DeviceNet board XFB01, and welder interface board XEW01 (are provided) as options for I/O expansion. The XRC 2001 cabinet has the expansion space for one board for arc welding and two boards for non-arc welding applications. Otherwise, the I/O expansion rack XEB01 (which supports MRC-compatible I/O expansion boards such as MARIO and MFB01) can be installed as an option.

XRC 2001 ROBOT CONTROLLER SPECIFICATIONS

CONTROLLER	Dimensions	750 x 1,100 x 550 mm (29.5" x 43.3" x 21.7")
	Approximate Mass	70 kg (154.4 lbs.)
	Cooling System	Indirect cooling
	Ambient Temperature	During operation: 0° C (32° F) to 45° C (113° F) During transport and storage: -10° C (14° F) to +60° C (140° F)
	Relative Humidity	90% max. non-condensing
	Primary Power Requirements	3-phase, 240/480/575 VAC at 50/60 Hz
	Grounding	Grounding resistance: ≤100 ohms Separate ground required
	Digital I/O	Specialized signals (hardware): 12 inputs/12 outputs General signals (standard max): 40 inputs/40 outputs Expandable to 256 inputs/256 outputs
	Position Feedback	Absolute encoder
	Program Memory	5,000 steps and 3,000 instructions
Interface	PC Flash Card, RS-232C (1 ch)	
SAFETY FEATURES	Safety Specs	Dual-channel Emergency Stop Pushbuttons, 3-position Deadman, Brake release switches Meets ANSI/RIA R15.06-1999
	Teach Lock Mode	Disables playback panel operation while TEACH mode is active
	Collision Detection	Collision avoidance zones and radial interference zones
	Machine Lock	Permits testing of peripheral devices without robot operation
Safety Interlock	Prevents robot operation while safety circuit is open	
PENDANT	Playback Panel Dim.	190 x 120 mm (7.5" x 4.7")
	Pendant Dim.	200 x 325 x 77 mm (7.9" x 12.8" x 3.0")
	Pendant Display	14.5 cm (5.7") backlit LCD
	Pendant Display Area	40 columns x 12 lines
	Pendant Languages	English, French, German, Japanese, Spanish
	Pendant Weight	2.62 lbs.
	Coordinate System	Joint, rectangular, cylindrical, tool, 24 user-coordinate frames
Speed Adjustment	Speeds can be adjusted in TEACH mode or while robot is operating	
Shortcuts	Windows-like direct access key and user-selectable screen key	
Interface	RS-232 for backup	
PROGRAMMING	Programming Language	INFORM II, icon-driven programming
	Robot Motion Control	Joint motion, linear, circular, spline interpolation
	Speed Adjustment	Percentage of maximum for joint motion; mm/sec, cm/min, in/min for displacement; °/sec for orientation
	I/O Instructions	Application-specific (ARCON, ARCOFF, LASERON, LASEROFF, HANDON, HANDOFF) Discrete I/O, 4-bit and 8-bit manipulation, analog output, optional analog input
MAINTENANCE	Maintenance Functions	System monitor, internal maintenance clocks
	Self-diagnostics	Classifies errors and major/minor alarms and displays data
	User Alarm Display	Displays alarm messages for peripheral devices
	Alarm Display	Alarm messages and alarm history
	I/O Diagnosis	Permits simulated enabled/disabled output
TCP Calibration	Automatically calibrates parameters for end-effectors	

www.motoman.com

YASKAWA

MOTOMAN ROBOTICS

MOTOMAN ROBOTICS
100 AUTOMATION WAY, MIAMISBURG, OHIO 45342
TEL: 937.847.6200 ■ FAX: 937.847.6277

TECHNICAL SPECIFICATIONS SUBJECT TO CHANGE WITHOUT NOTICE
DS-170-B ©2011 YASKAWA AMERICA, INC. JUNE 2011

MOTOMAN IS A REGISTERED TRADEMARK
ALL OTHER MARKS ARE THE TRADEMARKS AND
REGISTERED TRADEMARKS OF YASKAWA AMERICA, INC.