

# MOTOMAN-MH50 INSTRUCTIONS

**SUPPLEMENTARY FOR YR-MH00050-F00 (FOR FOOD GRADE GREASE)**

---

Upon receipt of the product and prior to initial operation, read these instructions thoroughly, and retain for future reference.

---

Part Number: 158926-1CD  
Revision: 2

## Introduction

This supplementary instruction manual describes how YR-MH00050-F00 (hereinafter referred to as MH00050-F00) is different from the YR-MH00050-A00 (hereinafter referred to as MH00050-A00).

Read this supplementary instruction manual thoroughly together with the following instruction manual:

“MOTOMAN-MH50 INSTRUCTIONS” (Type: YR-MH00050-A00 for standard specification, Part Number 156228-1CD)

## Point of Difference

The MH00050-F00 differs from the MH00050-A00 in the following point:

- (1) Specification for food grade grease

The differences are described based on "MOTOMAN-MH50 INSTRUCTIONS" (156228-1CD). Read this manual thoroughly replacing the subject matters for changes with this supplementary instruction manual.

Table 9-1: Inspection Items (Sheet 1 of 2) (Page 9-2 and Page 9-3)

Items <sup>1)</sup>	Schedule								Method	Operation	Inspection Charge		
	Daily	1000HCycle	3000HCycle	6000HCycle	12000HCycle	18000HCycle	24000HCycle	36000HCycle			Specified Personnel	Licensee	Service Company
1	Alignment mark	●							Visual	Check tram mark accordance and damage at the home position.	●	●	●
2	External lead	●							Visual	Check for damage and deterioration of leads.	●	●	●
3	Working area and manipulator	●							Visual	Clean the work area if dust or spatter is present. Check for damage and outside cracks.	●	●	●
4	S,L,U,R,B,T-axes motor	●							Visual	Check for grease leakage. <sup>2)</sup>	●	●	●
5	Baseplate mounting bolts		●						Spanner Wrench	Tighten loose bolts. Replace if necessary.	●	●	●
6	Cover mounting screws		●						Screwdriver, Wrench	Tighten loose bolts. Replace if necessary.	●	●	●
7	S,L,U,R,B,T-axes motor connector		●						Manual	Tighten loose bolts.	●	●	●
8	Connector base		●						Manual	Check for loose connectors.	●	●	●
9	Wire harness in manipulator					●			Visual Multimeter	Check for conduction between the main connector of base and intermediate connector with manually shaking the wire. Check for wear of protective spring <sup>3)</sup>		●	●
							●			Replace it 24000H intervals.			●
01	Limit switches and dogs (S,L,U-axes)			●					Screwdriver, Wrench, Multimeter	Tighten loose bolts. Replace if necessary.		●	●
11	Battery pack in manipulator							●		Replace the battery pack when the battery alarm occurs or the manipulator drove for 36000H.		●	●

Table 9-1: Inspection Items (Sheet 2 of 2) (Page 9-2 and Page 9-3)

Items <sup>1)</sup>	Schedule							Method	Operation	Inspection Charge		
	Daily	1000HCycle	3000HCycle	6000HCycle	12000HCycle	18000HCycle	24000HCycle			36000HCycle	Specified Personnel	Licensee
2) S-axis speed reducer			●					Grease Gun	Check for malfunction. (Replace if necessary.) <sup>4)</sup> Replace grease (3000H cycle). <sup>5)</sup> See section 9.3.1 on page 9-5		●	●
3) LU-axes speed reducers			●					Grease Gun	Check for malfunction. (Replace if necessary.) <sup>4)</sup> Replace grease (3000H cycle). <sup>5)</sup> See section 9.3.2 on page 9-11		●	●
4) R-axis speed reducers			●					Grease Gun	Check for malfunction. (Replace if necessary.) <sup>4)</sup> Replace grease (3000H cycle). <sup>5)</sup> See section 9.3.4 on page 9-15.		●	●
5) B,T-axes speed reducers B,T-axes gears			●					Grease Gun	Check for malfunction. (Replace if necessary.) <sup>4)</sup> Replace grease (3000H cycle). <sup>5)</sup> See section 9.3.5 on page 9-17.		●	●
6) Overhaul						●						●

1 Inspection No. correspond to the numbers in Fig. 9-1 "Inspection Items" on page 9-4.

2 The occurrence of a grease leakage indicates the possibility that grease has seeped into the motor. This can cause a motor breakdown. Contact your Yaskawa representative.

3 When checking for conduction with multimeter, connect the battery to "BAT" and "OBT" of connectors on the motor side for each axis, and then remove connectors on detector side for each axis from the motor. Otherwise, the home position may be lost. (Refer to section 9.3.6 "Notes for Maintenance" on page 9-19.)

4 The grease might leak out from the air breather or the internal pressure might rise in case the manipulator is used very frequently for the application such as handling.

5 For the grease, refer to Table 9-2 "Inspection Parts and Grease Used (Page 9-5)" on page 9-5.

*Table 9-2: Inspection Parts and Grease Used (Page 9-5)*

<b>No.</b>	<b>Grease Used</b>	<b>Inspected Parts</b>
13, 14, 15, 16	Cassida Grease EPS 00	Speed reducers for all axes B- and T-axis gears

The numbers in the above table correspond to the numbers in *Table 9-1 "Inspection Items (Page 9-2 and Page 9-3)"*.

### 9.3 Notes on Grease Exchange Procedures (Page 9-8)

Make sure to follow the instructions listed below at grease exchange. Failure to observe the following instructions may result in damage to a motor and a speed reducer.



- If grease is injected without removing the plug/screw from the grease exhaust port, the grease will leak inside a motor or an oil seal of a speed reducer will come off, which may result in damage to the motor. Make sure to remove the plug/screw.
- Do not install a joint, a hose, etc. to a grease exhaust port. Failure to observe this instruction may result in damage to the motor due to coming off of an oil seal.
- Make sure to use a grease pump to inject grease. Set air supply pressure to the grease pump at 0.3 MPa or less, and the grease injection rate at 8 g/s or less.
- Make sure to fill a hose on the grease inlet with grease to keep air from entering into the speed reducer.

#### 9.3.1 Grease Exchange for S-Axis Speed Reducer

Fig. 9-4: S-Axis Speed Reducer Diagram

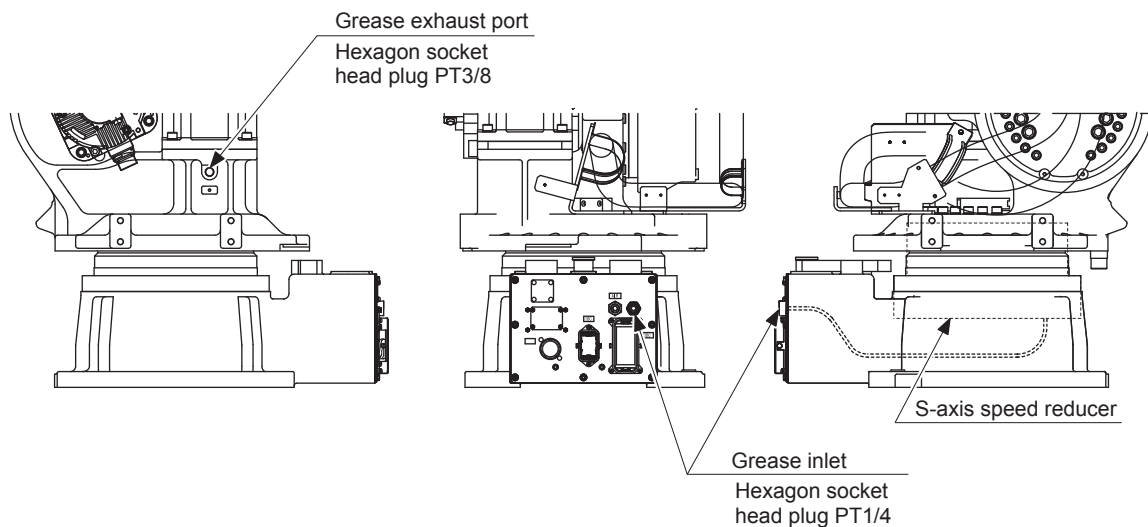

### 9.3.1.1 Grease Exchange

(Refer to *Fig. 9-4 "S-Axis Speed Reducer Diagram"*.) (Page 9-8)

1. Remove the hexagon socket head plugs from the grease inlet and grease exhaust port.



- If grease is injected without removing the plug/screw from the grease exhaust port, the grease will leak inside a motor or an oil seal of a speed reducer will come off, which may result in damage to the motor. Make sure to remove the plug/screw.
- Do not install a joint, a hose, etc. to a grease exhaust port. Failure to observe this instruction may result in damage to the motor due to coming off of an oil seal.

2. Install a grease zerk PT1/4 to the grease inlet. (The grease zerk is delivered with the manipulator.)
3. Inject grease through the grease inlet using a grease gun.
  - Grease type: Cassida Grease EPS 00
  - Amount of grease: approx. 2600 cc
  - Air supply pressure of grease pump: 0.3 MPa or less
  - Grease injection rate: 8 g/s or less
4. The grease exchange is completed when new grease appears in the grease exhaust port. (The new grease can be distinguished from the old grease by color.)
5. Move the S-axis for a few minutes to discharge excess grease.
6. Wipe the discharged grease with a cloth, and reinstall the plug. Before installing the plug, apply Three Bond 1206C on the thread part of the plug.



If the plug is installed while grease is being exhausted, grease will leak inside the motor and may cause a damage. Make sure to install the plug when the grease exhaust is completed.

7. Remove the grease zerk from the grease inlet, and reinstall the plug.

	9	Maintenance and Inspection
MH50	9.3	Notes on Grease Exchange Procedures (Page 9-8)

**9.3.2 Grease Exchange for L-Axis Speed Reducer (Page 9-11)**

*Fig. 9-5: L-Axis Speed Reducer Diagram*

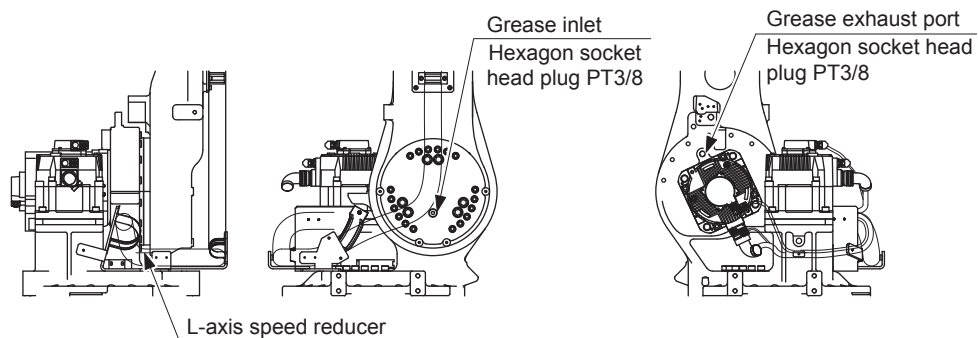



### 9.3.2.1 Grease Exchange

(Refer to *Fig. 9-5 "L-Axis Speed Reducer Diagram"*.) (Page 9-11)

1. Make the L-arm vertical to the ground.



- If grease is injected with the plug on, the grease will leak inside the motor and may cause a damage. Make sure to remove the plug before the grease injection.
- Do not install a joint, a hose, etc. to a grease exhaust port. Failure to observe this instruction may result in damage to the motor due to coming off of an oil seal.

2. Remove the hexagon socket head plugs from the grease inlet and grease exhaust port.
3. Install the grease zerk PT3/8 to the grease inlet.  
(The grease zerk is delivered with the manipulator.)
4. Inject grease through the grease inlet using a grease gun.
  - Grease type: Cassida Grease EPS 00
  - Amount of grease: approx. 1650 cc
  - Air supply pressure of grease pump: 0.3 MPa or less
  - Grease injection rate: 8 g/s or less
5. The grease discharge is complete when new grease appears from the exhaust port. The new grease can be distinguished from the old grease by color.
6. Move the L-axis for a few minutes to discharge the excess grease.
7. Wipe the discharged grease with a cloth and reinstall the plug to the exhaust port.  
Before installing the plug, apply Three Bond 1206C on the thread part of the plug.



If the plug is installed while grease is being exhausted, grease will leak inside the motor and may cause a damage. Make sure to install the plug when the grease exhaust is completed.

8. Remove the grease zerk from the grease inlet, and reinstall the plug.

9.3.3 Grease Exchange for U-Axis Speed Reducer (Page 9-13)

Fig. 9-6: U-Arm Posture

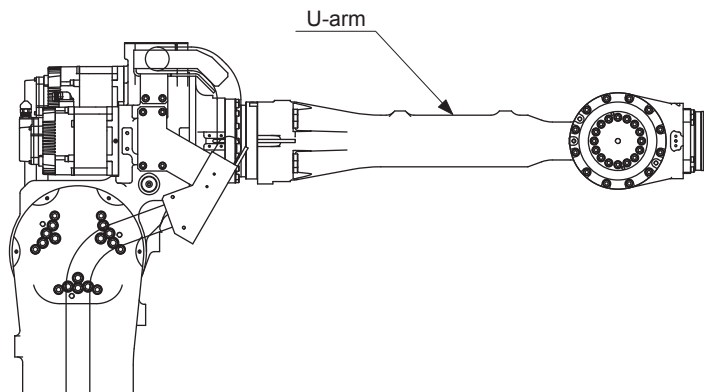
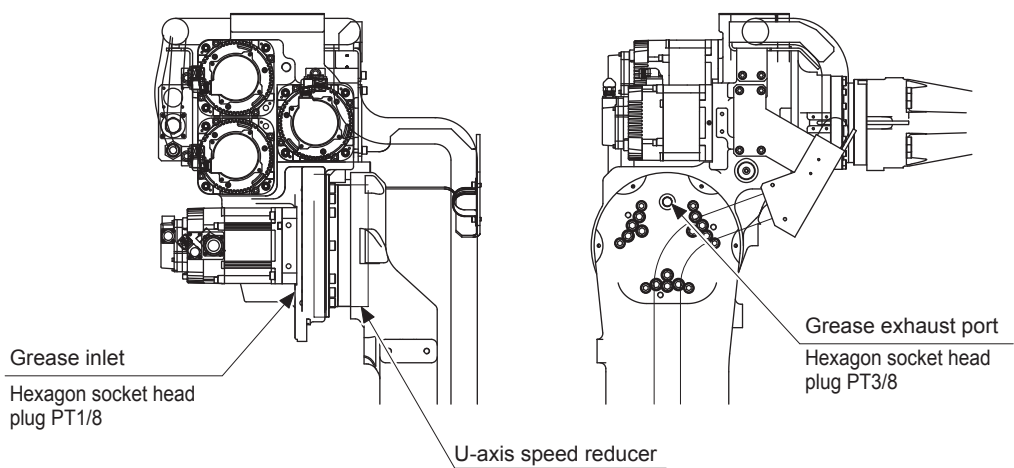

Fig. 9-7: U-axis Speed Reducer Diagram



## 9.3.3.1 Grease Exchange

(Refer to *Fig. 9-7 "U-axis Speed Reducer Diagram"*.) (Page 9-13)

1. Set the U-arm in the position as shown in *Fig. 9-6 "U-Arm Posture"* (Page 9-13). (Make the L-arm vertical to the ground.)
2. Remove the hexagon socket head plugs from the grease exhaust port and the grease inlet.



- If grease is injected with the plug on, the grease will leak inside the motor and may cause a damage. Make sure to remove the plug before the grease injection.
- Do not install a joint, a hose, etc. to a grease exhaust port. Failure to observe this instruction may result in damage to the motor due to coming off of an oil seal.

3. Install the grease zerk PT1/8 to the grease inlet. (The grease zerk is delivered with the manipulator.)
4. Inject grease through the grease inlet using a grease gun.
  - Grease type: Cassida Grease EPS 00
  - Amount of grease: approx. 700 cc
  - Air supply pressure of grease pump: 0.3 MPa or less
  - Grease injection rate: 8 g/s or less
5. The grease discharge is complete when new grease appears from the exhaust port. The new grease can be distinguished from the old grease by color.
6. Move the U-axis for a few minutes to discharge the excess grease.
7. Wipe the discharged grease with a cloth and reinstall the plug to the exhaust port.  
Before installing the plug, apply Three Bond 1206C on the thread part of the plug.



If the plug is installed while grease is being exhausted, grease will leak inside the motor and may cause a damage. Make sure to install the plug when the grease exhaust is completed.

8. Remove the grease zerk from the grease inlet, and reinstall the plug.

### 9.3.4 Grease Exchange for R-Axis Speed Reducer (Page 9-15)

Fig. 9-8: R-Axis Speed Reducer Diagram

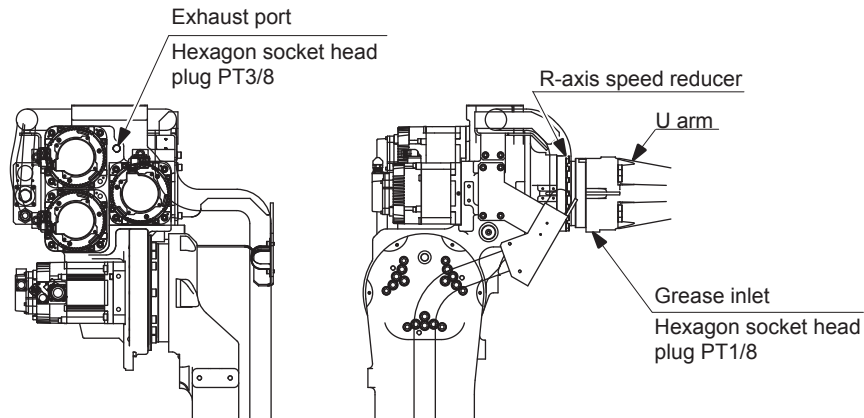

#### 9.3.4.1 Grease Exchange

(Refer to Fig. 9-8 "R-Axis Speed Reducer Diagram".) (Page 9-15)

1. Remove the hexagon socket head plugs from the grease inlet and grease exhaust port.

**NOTE**

- If grease is injected with the plug on, the grease will leak inside the motor and may cause a damage. Make sure to remove the plug before the grease injection.
- Do not install a joint, a hose, etc. to a grease exhaust port. Failure to observe this instruction may result in damage to the motor due to coming off of an oil seal.

2. Install a grease zerk PT1/8 to the grease inlet. (The grease zerk is delivered with the manipulator.)
3. Inject grease through the grease inlet using a grease gun.
  - Grease type: Cassida Grease EPS 00
  - Amount of grease: approx. 3500 cc
  - Air supply pressure of grease pump: 0.3 MPa or less
  - Grease injection rate: 8 g/s or less
4. The grease exchange is completed when new grease appears in the grease exhaust port. (The new grease can be distinguished from the old grease by color.)
5. Move the R-axis for a few minutes to discharge excess grease.
6. Wipe the discharged grease with a cloth, and reinstall the plug. Before installing the plug, apply Three Bond 1206C on the thread part of the plug.

**NOTE**

- If the plug is installed while grease is being exhausted, grease will leak inside the motor and may cause a damage. Make sure to install the plug when the grease exhaust is completed.

7. Remove the grease zerk from the grease inlet, and reinstall the plug.

### 9.3.5 Grease Exchange for B- and T-axes Speed Reducer and Gear Parts (Page 9-17)

Fig. 9-9: B- and T-axes Speed Reducer and Gear Parts

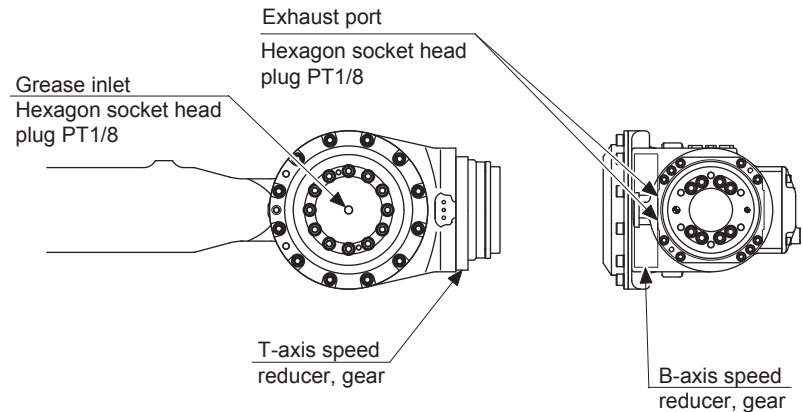

#### 9.3.5.1 Grease Exchange

(Refer to Fig. 9-9 "B- and T-axes Speed Reducer and Gear Parts".) (Page 9-17)

1. Remove the hexagon socket head plugs from the grease inlet and grease exhaust ports.



- If grease is injected with the plug on, the grease will leak inside the motor and may cause a damage. Make sure to remove the plug before the grease injection.
- Do not install a joint, a hose, etc. to a grease exhaust port. Failure to observe this instruction may result in damage to the motor due to coming off of an oil seal.

2. Install a grease zerk PT1/8 to the grease inlet. (The grease zerk is delivered with the manipulator.)
3. Inject grease through the grease inlet using a grease gun.
  - Grease type: Cassida Grease EPS 00
  - Amount of grease: approx. 1500 cc
  - Air supply pressure of grease pump: 0.3 MPa or less
  - Grease injection rate: 8 g/s or less
4. The grease exchange is completed when new grease appears in the grease exhaust port. (The new grease can be distinguished from the old grease by color.)
5. Move the B-axis for a few minutes to discharge excess grease.
6. Wipe the discharged grease with a cloth, and reinstall the plug. Before installing the plug, apply Three Bond 1206C on the thread part of the plug.



If the plug is installed while grease is being exhausted, grease will leak inside the motor and may cause a damage. Make sure to install the plug when the grease exhaust is completed.

7. Remove the grease zerk from the grease inlet, and reinstall the plug.

## 10 Recommended Spare Parts (Page 10-1)

It is recommended to keep the parts and components in the following table in stock as spare parts for the MOTOMAN-MH50. Product performance cannot be guaranteed when using spare parts from any company other than Yaskawa. The spare parts are ranked as follows:

- Rank A: Expendable and frequently replaced parts.
- Rank B: Parts for which replacement may be necessary as a result of frequent operation.
- Rank C: Drive unit.



For replacing parts in Rank B or Rank C, contact your Yaskawa representative.

Table 10-1: Spare Parts for YR-MH00050-F00 (Sheet 1 of 2)

Rank	Parts No.	Name	Type	Manufacturer	Qty	Qty per Unit	Remarks
A	1	Grease	Cassida Grease EPS 00	Yaskawa	16 kg	-	For the speed reducer in each axis
A	2	Liquid Gasket	Three Bond 1206C	Three Bond Co., Ltd.	-	-	
A	3	Battery Pack	HW9470932-A	Yaskawa	1	1	For internal wire harness replacement
A	4	Battery Pack	HW0470360-A	Yaskawa	1	1	
B	5	S-axis Speed Reducer	HW0387752-B	Yaskawa	1	1	For the manipulator assembled after Apr.2, 2014
			HW1382898-B	Yaskawa	1	1	
B	6	S-axis Input Gear	HW0313741-1	Yaskawa	1	1	
B	7	L-axis Speed Reducer	HW9381465-G	Yaskawa	1	1	
B	8	L-axis Input Gear	HW9482771-A	Yaskawa	1	1	
B	9	U-axis Speed Reducer	HW0387753-A	Yaskawa	1	1	
B	10	U-axis Input Gear	HW0313740-1	Yaskawa	1	1	
B	11	R-axis Speed Reducer	HW0387754-A			1	
B	12	B-axis Speed Reducer	HW0387737-B	Yaskawa	1	1	
B	13	T-axis Speed Reducer	HW0389043-A	Yaskawa	1	1	
C	14	S-axis AC Servomotor	SGMRV-30ANA-YR11 HW0388669-A	Yaskawa	1	1	
C	15	L-axis AC Servomotor	SGMRV-37ANA-YR11 HW0388670-A	Yaskawa	1	1	

Table 10-1: Spare Parts for YR-MH00050-F00 (Sheet 2 of 2)

Rank	Parts No.	Name	Type	Manufacturer	Qty	Qty per Unit	Remarks
C	16	U-axis AC Servomotor	SGMRV-13ANA-YR11 HW0388666-A	Yaskawa	1	1	
C	17	R-,B-,T-axes AC Servomotor	SGMRV-09ANA-YR11 HW0388665-A	Yaskawa	1	3	
C	18	Internal Wire Harness	HW0174688-A	Yaskawa	1	1	
C	19	Connector Base	HW0374034-B	Yaskawa	1	1	

# MOTOMAN-MH50 INSTRUCTIONS

## SUPPLEMENTARY FOR YR-MH00050-F00 (FOR FOOD GRADE GREASE)

---

### HEAD OFFICE

2-1 Kurosakishiroishi, Yahatanishi-ku, Kitakyushu 806-0004, Japan  
Phone +81-93-645-7703 Fax +81-93-645-7802

YASKAWA America Inc. (Motoman Robotics Division)  
100 Automation Way, Miamisburg, OH 45342, U.S.A.  
Phone +1-937-847-6200 Fax +1-937-847-6277

YASKAWA Europe GmbH (Robotics Division)  
Yaskawastrasse 1, 85391 Allershausen, Germany  
Phone +49-8166-90-100 Fax +49-8166-90-103

YASKAWA Nordic AB  
Bredbandet 1 vån. 3 varvsholmen 392 30 Kalmar, Sweden  
Phone +46-480-417-800 Fax +46-480-417-999

YASKAWA Electric (China) Co., Ltd.  
22/F One Corporate Avenue No.222, Hubin Road, Huangpu District, Shanghai 200021, China  
Phone +86-21-5385-2200 Fax +86-21-5385-3299

YASKAWA SHOUGANG ROBOT Co. Ltd.  
No7 Yongchang North Road, Beijing E&T Development Area, China 100176  
Phone +86-10-6788-2858 Fax +86-10-6788-2878

YASKAWA India Private Ltd. (Robotics Division)  
#426, Udyog Vihar, Phase- IV, Gurgaon, Haryana, India  
Phone +91-124-475-8500 Fax +91-124-475-8542

YASKAWA Electric Korea Co., Ltd  
9F, Kyobo Securities Bldg., 26-4, Yeouido-dong, Yeongdeungpo-gu, Seoul 150-737, Korea  
Phone +82-2-784-7844 Fax +82-2-784-8495

YASKAWA Electric Taiwan Corporation  
12F, No.207, Sec. 3, Beishin Rd., Shindian District, New Taipei City 23143, Taiwan  
Phone +886-2-8913-1333 Fax +886-2-8913-1513

YASKAWA Electric (Singapore) PTE Ltd.  
151 Lorong Chuan, #04-02A, New Tech Park, Singapore 556741  
Phone +65-6282-3003 Fax +65-6289-3003

YASKAWA Electric (Thailand) Co., Ltd.  
252/125-126 27th Floor, Tower B Muang Thai-Phatra Complex Building,  
Rachadaphisek Road, Huaykwang, Bangkok 10320, Thailand  
Phone +66-2693-2200 Fax +66-2693-4200

PT. YASKAWA Electric Indonesia  
Secure Building-Gedung B Lantai Dasar & Lantai 1 Jl. Raya Protokol Halim Perdanakusuma,  
Jakarta 13610, Indonesia  
Phone +62-21-2982-6470 Fax +62-21-2982-6741

---

Specifications are subject to change without notice  
for ongoing product modifications and improvements.