

DX100 OPTIONS JARCR-XOI02B BOARD INSTRUCTIONS

FOR I/O EXPANSION FOR EUROPEAN STANDARDS

Upon receipt of the product and prior to initial operation, read these instructions thoroughly, and retain for future reference.

MOTOMAN INSTRUCTIONS

MOTOMAN-□□□ INSTRUCTIONS
DX100 INSTRUCTIONS
DX100 OPERATOR'S MANUAL
DX100 MAINTENANCE MANUAL

The DX100 operator's manuals above correspond to specific usage.
Be sure to use the appropriate manual.

Part Number: 156527-1CD
Revision: 1



MANDATORY

- This manual explains the JARCR-XOI02B board of the DX100 system and general operations. Read this manual carefully and be sure to understand its contents before handling the DX100.
- General items related to safety are listed in Chapter 1: Safety of the DX100 Instructions. To ensure correct and safe operation, carefully read the DX100 Instruction before reading this manual.



CAUTION

- Some drawings in this manual are shown with the protective covers or shields removed for clarity. Be sure all covers and shields are replaced before operating this product.
- The drawings and photos in this manual are representative examples and differences may exist between them and the delivered product.
- YASKAWA may modify this model without notice when necessary due to product improvements, modifications, or changes in specifications. If such modification is made, the manual number will also be revised.
- If your copy of the manual is damaged or lost, contact a YASKAWA representative to order a new copy. The representatives are listed on the back cover. Be sure to tell the representative the manual number listed on the front cover.
- YASKAWA is not responsible for incidents arising from unauthorized modification of its products. Unauthorized modification voids your product's warranty.

Notes for Safe Operation

Read this manual carefully before installation, operation, maintenance, or inspection of the DX100.

In this manual, the Notes for Safe Operation are classified as “WARNING,” “CAUTION,” “MANDATORY,” or “PROHIBITED.”



WARNING

Indicates a potentially hazardous situation which, if not avoided, could result in death or serious injury to personnel.



CAUTION

Indicates a potentially hazardous situation which, if not avoided, could result in minor or moderate injury to personnel and damage to equipment. It may also be used to alert against unsafe practices.



MANDATORY

Always be sure to follow explicitly the items listed under this heading.



PROHIBITED

Must never be performed.

Even items described as “CAUTION” may result in a serious accident in some situations. At any rate, be sure to follow these important items.



To ensure safe and efficient operation at all times, be sure to follow all instructions, even if not designated as “CAUTION” and “WARNING.”



PROHIBITED

- Do not use or keep the board in the following environmental conditions.
 - Where exposed to direct sunshine
 - Where vibration or impact occurs
 - Where high humidity exists
 - Where a strong magnetic field exists
 - Where much dust exists
 - Where a sudden change in the temperature occurs
 - Where corrosive gases occur
 - Where condensation occurs

Improper usage of the board may damage the board.



WARNING

- Before operating the manipulator, check that servo power is turned OFF when the emergency stop buttons on the front door of the DX100 and programming pendant are pressed. When the servo power is turned OFF, the SERVO ON LED on the programming pendant is turned OFF.

Injury or damage to machinery may result if the emergency stop circuit cannot stop the manipulator during an emergency. The manipulator should not be used if the emergency stop buttons do not function.

Figure 1: Emergency Stop Button



- Once the emergency stop button is released, clear the cell of all items which could interfere with the operation of the manipulator. Then turn the servo power ON.

Injury may result from unintentional or unexpected manipulator motion.

Figure 2: Release of Emergency Stop

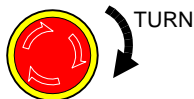

- Observe the following precautions when performing teaching operations within the P-point maximum envelope of the manipulator
 - View the manipulator from the front whenever possible.
 - Always follow the predetermined operating procedure.
 - Keep in mind the emergency response measures against the manipulator's unexpected motion toward you.
 - Ensure that you have a safe place to retreat in case of emergency.

Improper or unintended manipulator operation may result in injury.

- Confirm that no persons are present in the P-point maximum envelope of the manipulator and that you are in a safe location before:
 - Turning ON the DX100 power
 - Moving the manipulator with the programming pendant
 - Running the system in the check mode
 - Performing automatic operations
- Injury may result if anyone enters the P-point maximum envelope of the manipulator during operation. Always press an emergency stop button immediately if there are problems. The emergency stop buttons are located on the right of the front door of the DX100 and the programming pendant.



WARNING

- Do not touch the inside of the panel for 5 minutes after the power is turned OFF.

The remaining charged voltage in the capacitor may cause an electric shock or an injury.

- Be sure to close the door and install the protection cover while the power is turned ON.

Failure to observe this warning may result in a fire or an electric shock.



CAUTION

- Perform the following inspection procedures prior to conducting manipulator teaching. If problems are found, repair them immediately, and be sure that all other necessary processing has been performed.
 - Check for problems in manipulator movement.
 - Check for damage to insulation and sheathing of external wires.
- Always return the programming pendant to the hook on the cabinet of the DX100 after use.

The programming pendant can be damaged if it is left in the manipulator's work area, on the floor, or near fixtures.

Read and understand the Explanation of Warning Labels in the DX100 Instructions before operating the manipulator:

- The wiring and mounting must be performed by authorized and qualified personnel.

Failure to observe this caution may result in a fire or an electric shock.

- Make sure that there is no foreign matter such as metal chips on the board.

In case of malfunction, etc. it may result in an injury or damage the board.

- Make sure that there is no damage or deflection of parts on the board.

In case of malfunction, etc. it may result in an injury or damage the board.

- Correctly connect each cable and connector.

Failure to observe this caution may result in a fire or damage the board.

- Set the switches, etc. correctly.

Malfunction, caused by an incorrect setting, may result in an injury or damage the board.

- Never touch the mounting surfaces of the board parts directly with fingers.

The generated static electricity may damage the IC.

- Never touch the soldered surfaces of the board directly with fingers. Protrusions on the soldered surface may result in an injury.

- No shock to the board.

The shock may damage the board.

Definition of Terms Used Often in This Manual

The MOTOMAN is the YASKAWA industrial robot product.

The MOTOMAN usually consists of the manipulator, the controller, the programming pendant, and manipulator cables.

In this manual, the equipment is designated as follows.

Equipment	Manual Designation
DX100 Controller	DX100
DX100 Programming Pendant	Programming Pendant
Cable between the manipulator and the controller	Manipulator cable
JARCR-XOI02B board	XOI02B board

Descriptions of the programming pendant keys, buttons, and displays are shown as follows:

Equipment	Manual Designation	
Programming Pendant	Character Keys	The keys which have characters printed on them are denoted with []. ex. [ENTER]
	Symbol Keys	The keys which have a symbol printed on them are not denoted with [] but depicted with a small picture. ex. page key  The cursor key is an exception, and a picture is not shown.
	Axis Keys Numeric Keys	"Axis Keys" and "Numeric Keys" are generic names for the keys for axis operation and number input.
	Keys pressed simultaneously	When two keys are to be pressed simultaneously, the keys are shown with a "+" sign between them, ex. [SHIFT]+[COORD]
	Displays	The menu displayed in the programming pendant is denoted with { }. ex. {JOB}

Description of the Operation Procedure

In the explanation of the operation procedure, the expression "Select ●●●" means that the cursor is moved to the object item and the SELECT key is pressed, or that the item is directly selected by touching the screen.

Table of Contents

1 Outline

1.1 System Configuration Example	1-1
--	-----

2 Hardware Specifications

2.1 Board External View	2-1
2.2 Board Specifications	2-1
2.3 User Input/Output Connectors	2-2

3 Setting the Functions

3.1 Function Setting Switches	3-1
3.2 Setting Method	3-2

4 Mounting the XOIO2B Board

4.1 Opening Front Door of the DX100	4-2
4.2 Confirming the Switch Settings on the XOIO2B Board.....	4-2
4.3 Mounting the XOIO2B Board on the DX100.....	4-2
4.4 Connecting Each Cable	4-3
4.5 Closing the Front Door of the DX100.....	4-4

5 I/O Signal Allocation

5.1 I/O Module Setting	5-1
5.2 I/O Data	5-5

6 I/O Circuits

6.1 Input Circuit.....	6-1
6.1.1 Input Circuit 1 (CN10 to CN13).....	6-1
6.2 Output Circuits	6-2
6.2.1 Output Circuit 1 CN12 and CN13 (Transistor Output)	6-2
6.2.2 Output Circuit 2 CN10 and CN11 (Relay Output).....	6-3
6.3 Connection Example.....	6-4
6.3.1 Handling Application.....	6-5
6.3.2 Arc Welding, Spot Welding, and General-Purpose Applications.....	6-9

1 Outline

This instruction manual describes the I/O expansion board, the XOI02B. The XOI02B board can be used to expand the number of I/O points when more DX100 I/O points are needed.

1.1 System Configuration Example

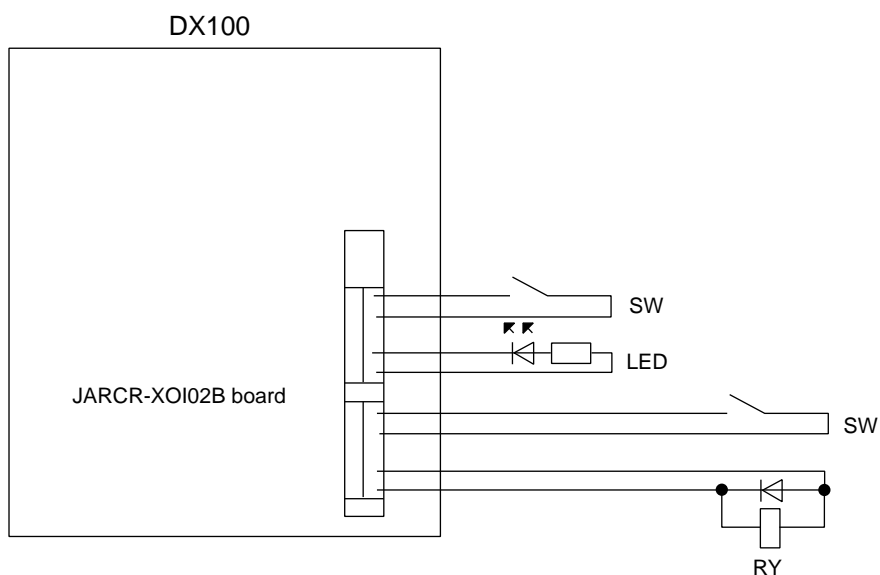

2 Hardware Specifications

2.1 Board External View

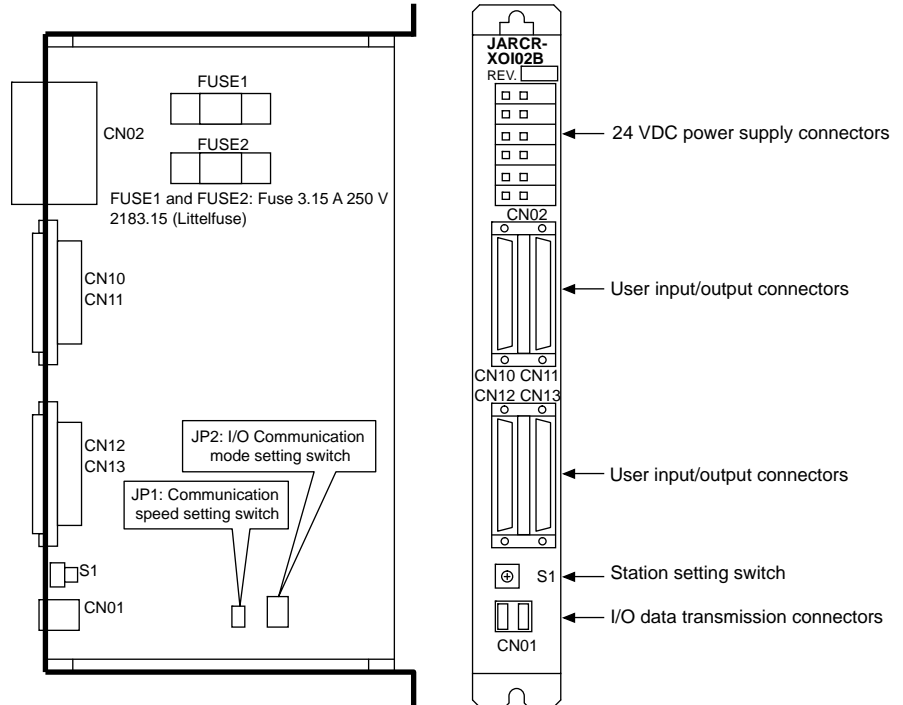

2.2 Board Specifications

Items	Specifications
Board mounting position	Optional board mounting space in the DX100
Number of I/O points	Input: 40 points Output: 40 points (PNP transistor output 24 points, relay output 16 points)

2.3 User Input/Output Connectors

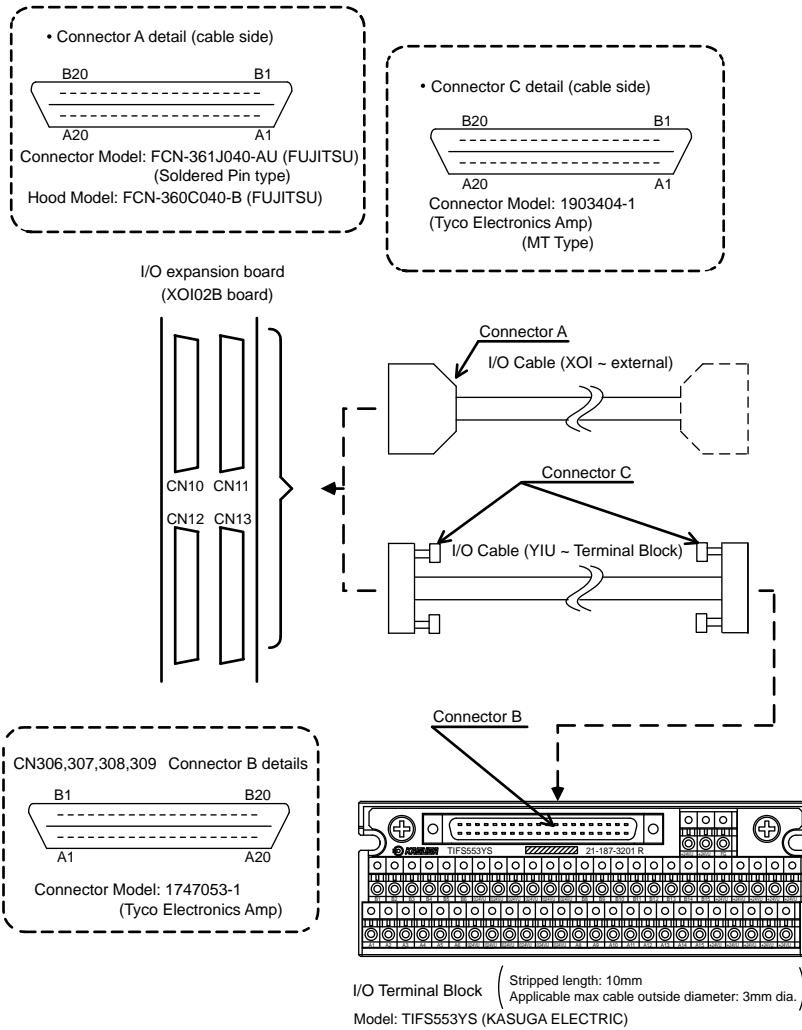





3 Setting the Functions

3.1 Function Setting Switches

The section explains the switches that set the functions of the XOIO2B board. Make the proper settings following the instructions. For details of the settings, refer to *page 3-2*.

- S1: Sets the stations for the XOIO2B board on the DX100.
The setting range for a station is 1 (ST#01) to D (ST#13).
Do not set the station to 0 (ST#00), E (ST#14), or F (ST#15).
- JP1: Sets the communication speed.
This switch sets the communication speed to 4 Mbps or 10 Mbps.
Be sure to set this switch to 4 Mbps.
Do not set it to 10 Mbps.
If the number of I/O points on the XOIO2B board does not appear on the Programming Pendant, check if the communication cable or power cable is connected correctly, referring to the I/O module setting in *Chapter 5 "I/O Signal Allocation" on page 5-1*. When the cables are correctly connected, the JP1 may be set to 10 Mbps.
Change the setting to 4 Mbps.
- JP2: Sets the communication mode.
This switch sets the communication mode to 16 bytes, 17 bytes, or 32 bytes.
Be sure to set this switch to 17 bytes.
Do not set it to 16 bytes and 32 bytes.
If the number of I/O points on the XOIO2B board does not appear on the Programming Pendant, check if the communication cable or power cable is connected correctly, referring to the I/O module setting in *Chapter 5 "I/O Signal Allocation" on page 5-1*. When the cables are correctly connected, the JP2 may be set to 16 bytes or 32 bytes.
Change the setting to 17 bytes.

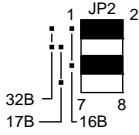
3.2 Setting Method

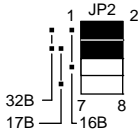
Switches	Setting Method																
S1 Station setting	 <p>Sets the stations. The relation between the switch setting and the station is shown below. Turn the arrow to the number corresponding to the desired station. (Use a flat tip screwdriver.)</p> <table> <tr> <td>0: Cannot be set</td> <td>8: ST#08</td> </tr> <tr> <td>1: ST#01</td> <td>9: ST#09</td> </tr> <tr> <td>2: ST#02</td> <td>A: ST#10</td> </tr> <tr> <td>3: ST#03 (Default setting)</td> <td>B: ST#11</td> </tr> <tr> <td>4: ST#04</td> <td>C: ST#12</td> </tr> <tr> <td>5: ST#05</td> <td>D: ST#13</td> </tr> <tr> <td>6: ST#06</td> <td>E: Can not be set</td> </tr> <tr> <td>7: ST#07</td> <td>F: Can not be set</td> </tr> </table> <p>The number after ST# is the station number displayed on the programming pendant of the DX100 when setting I/O modules. The default setting is ST#03.</p>	0: Cannot be set	8: ST#08	1: ST#01	9: ST#09	2: ST#02	A: ST#10	3: ST#03 (Default setting)	B: ST#11	4: ST#04	C: ST#12	5: ST#05	D: ST#13	6: ST#06	E: Can not be set	7: ST#07	F: Can not be set
0: Cannot be set	8: ST#08																
1: ST#01	9: ST#09																
2: ST#02	A: ST#10																
3: ST#03 (Default setting)	B: ST#11																
4: ST#04	C: ST#12																
5: ST#05	D: ST#13																
6: ST#06	E: Can not be set																
7: ST#07	F: Can not be set																
JP1 Setting of the communication speed	 <p>Short circuit between 1 and 2: 10 Mbps *Setting unavailable</p>  <p>Short circuit between 2 and 3: 4 Mbps (Default setting) *Setting indispensable</p>																
JP2 Setting of the I/O communication mode	 <p>Short circuit between 1 and 2, 5 and 6: 16 byte mode *Setting unavailable</p>  <p>Short circuit between 3 and 4, 7 and 8: 17 byte mode (Default setting) *Setting indispensable</p>  <p>Short circuit between 1 and 2, 3 and 4: 32 byte mode *Setting unavailable</p>																



Do not set S1 to 0, E or F. Do not set more than one board to one ST#.

Improper settings may prevent the I/O module from being recognized correctly.

Also, do not set JP1 to 10 Mbps and do not set JP2 to 16 bytes or 32 bytes.

If 10 Mbps, 16 bytes, and 32 bytes are selected, the I/O module is not recognized.

4 Mounting the XOI02B Board



WARNING

- Before wiring, be sure to turn OFF the power supply and put up a warning sign, such as “DO NOT TURN ON THE POWER.”

Failure to observe this warning may result in an electric shock or an injury.

- Do not touch the inside of the panel for 5 minutes after the power is turned OFF.

The remaining charged voltage in the capacitor may cause an electric shock or an injury.

- Be sure to close the door and install the protection cover while the power is turned ON.

Failure to observe this warning may result in a fire or an electric shock.



CAUTION

- The wiring and mounting must be performed by authorized and qualified personnel.

Failure to observe this caution may result in a fire or an electric shock.

- Make sure that there is no foreign matter such as metal chips on the board.

In case of malfunction, etc. it may result in an injury or damage the board.

- Make sure that there is no damage or deflection of parts on the board.

In case of malfunction, etc. it may result in an injury or damage the board.

- Correctly connect each cable and connector.

Failure to observe this caution may result in a fire or damage the board.

- Set the switches, etc. correctly.

Malfunction, caused by an incorrect setting, may result in an injury or damage the board.

- Never touch the mounting surfaces of the board parts directly with fingers.

The generated static electricity may damage the IC.

- Never touch the soldered surfaces of the board directly with fingers. Protrusions on the soldered surface may result in an injury.

- No shock to the board.

The shock may damage the board.

4.1 Opening Front Door of the DX100

Mount the XOI02B board in the following manner.

1. Turn the two door locks on the front face of the DX100 clockwise for 90° with a coin or a flat tip screwdriver.

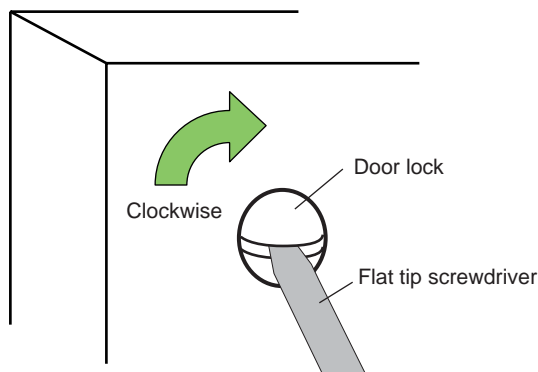

2. With the door locks turned clockwise for 90°, turn the main switch handle to the "OFF" position, and slowly open the door.

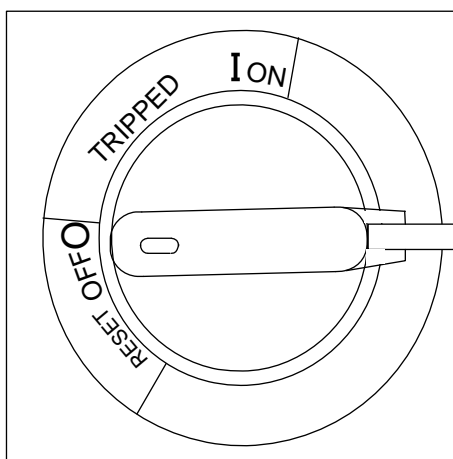

4.2 Confirming the Switch Settings on the XOI02B Board

1. Be sure that the settings of switches on the board are correct.
2. For the switch settings, refer to *Chapter 3 "Setting the Functions" on page 3-1*.

4.3 Mounting the XOI02B Board on the DX100

1. Be sure that the main power supply is OFF.
2. Fix the XOI02B board on the DX100 with the board fixing screws securely tightened.

4.4 Connecting Each Cable

1. Connect the 24 VDC power supply cable to the CN02 on the XOIO2B board.
2. Connect the I/O communication cable to the CN01 on the XOIO2B board. Disconnect the terminal connector from CN0303 (right) on the JZNC-YIU02 unit, and connect it to the non-occupied CN01 on the XOIO2B board.
3. Connect the I/O cables to the CN10 through CN13 on the XOIO2B board.

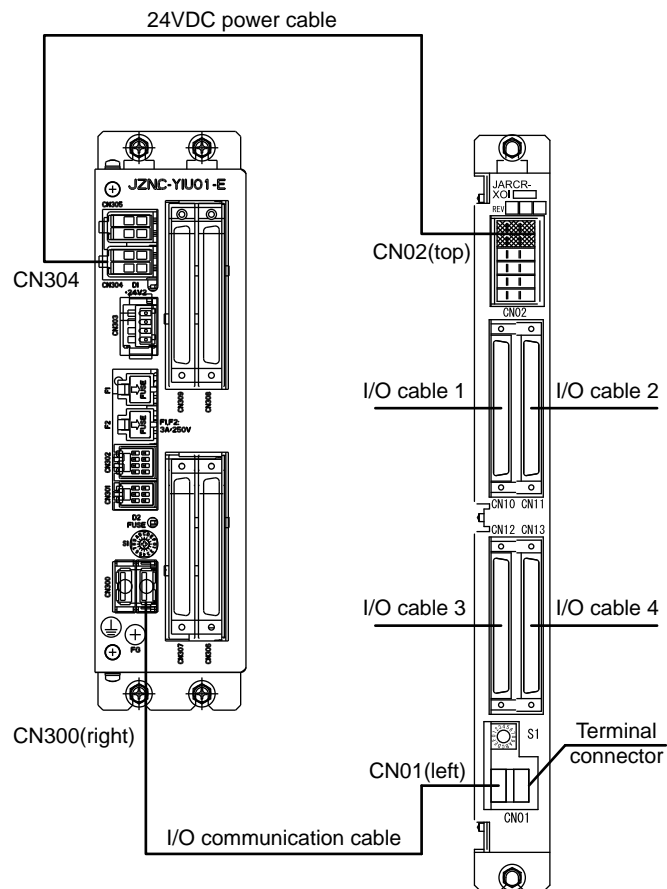

A dummy connector is inserted into the CN02 of the 24 VDC power supply connector on the XOIO2B board.

Do not remove this connector because it is inserted to prevent incorrect cable connections. Removing this connector may result in incorrect connection of the 24 VDC power cable to the CN02. This prevents power from being supplied normally to the board, and the board may not start up.

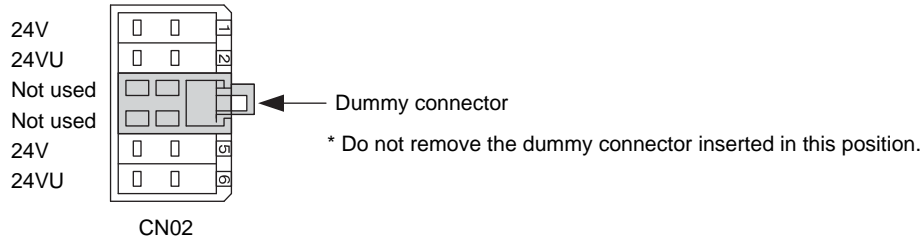

NOTE

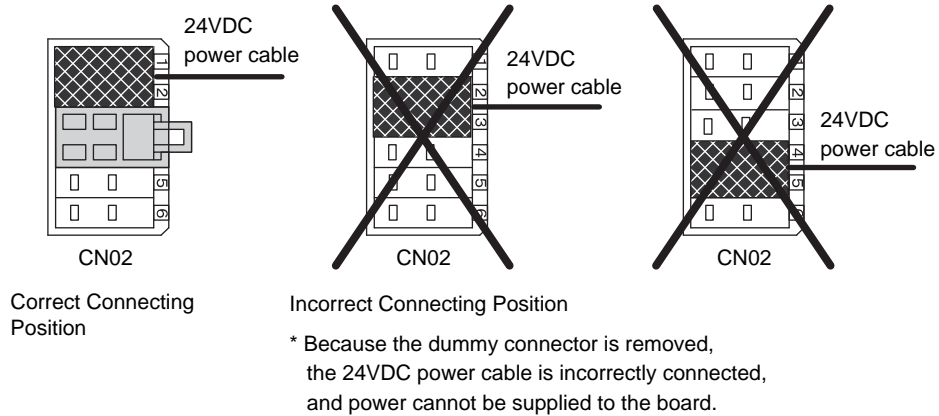

4.5 Closing the Front Door of the DX100

1. Close the door slowly.
2. Turn the two door locks counterclockwise for 90° using a coin or a flat tip screwdriver.

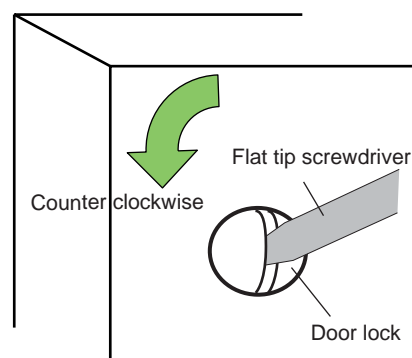

5 I/O Signal Allocation

5.1 I/O Module Setting

In order to use a XOIO2B board on the DX100, perform the I/O module setting in the following manner.

Make sure that the power supply to the DX100 is OFF. Then, mount the XOIO2B board, for which all of its switches have been set, inside the DX100. For the board mounting method, refer to *Chapter 4 "Mounting the XOIO2B Board"* on page 4-1.



Add an I/O module in the management mode.

In the operation mode and the editing mode, the settings are for reference only.

1. Turn the power supply ON again while pressing [MAIN MENU] simultaneously.
 - The main menu appears.



2. Select {SYSTEM} under the main menu.
 - The sub menu appears.

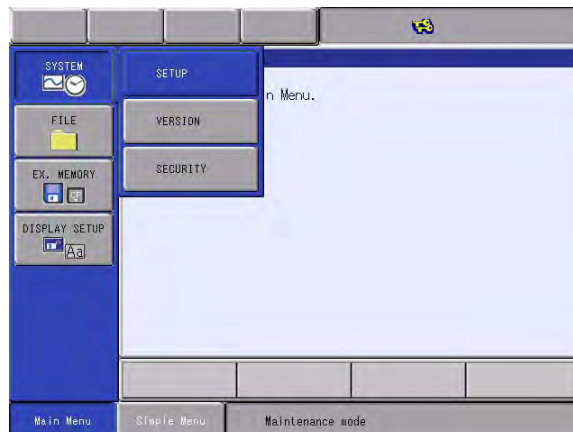

3. Change the security mode to management mode.

4. Select {SETUP}.

- The SETUP window appears.



5. Select {IO MODULE}.

- The current mounted status of the I/O modules is shown as in the following example.

ST#	DI	DO	AI	AO BOARD
05	-	-	-	NONE
06	-	-	-	NONE
07	-	-	-	NONE
08	-	-	-	NONE
09	-	-	-	NONE
10	-	-	-	NONE
11	-	-	-	NONE
12	-	-	-	NONE
13	-	-	-	NONE
14	0040	0040	-	YIU02
15	-	-	-	NONE
16	-	-	-	NONE
17	-	-	-	NONE
18	-	-	-	NONE
19	-	-	-	NONE

- To view the current mounted status of the I/O modules for stations that are not displayed, press [ENTER].

ST#	DI	DO	AI	AO BOARD
00	-	-	-	NONE
01	-	-	-	NONE
02	-	-	-	NONE
03	0040	0040	-	XI02
04	-	-	-	NONE
05	-	-	-	NONE
06	-	-	-	NONE
07	-	-	-	NONE
08	-	-	-	NONE
09	-	-	-	NONE
10	-	-	-	NONE
11	-	-	-	NONE
12	-	-	-	NONE
13	-	-	-	NONE
14	0040	0040	-	YIU02

6. Confirm the status of the mounted I/O module.

- Only the I/O modules mounted on DX100 are displayed. Confirm that each station (ST#) indicates the actual mounted status of the I/O module.
- The following table lists the meanings of each line.

ST#	Station address of I/O module
DI	Number of digital input points ¹⁾
DO	Number of digital output points ¹⁾
AI	Number of analog input points ¹⁾
AO	Number of analog output points ¹⁾
BOARD	Circuit board type ²⁾

1 A hyphen "-" indicates the corresponding I/O module is not mounted.

2 If the system cannot recognize the circuit board type, "*****" is shown. No problem will occur as long as the values displayed in DI, DO, AI, and AO are correct.

- In the example shown on the display, the configuration of boards are as follows.

ST#03: JARCR-XOI02B board
(digital input 40 points, digital output 40 points).
Switch S1: set to 3 (This value becomes the ST#).

ST#14: JZNC-YIU02-E unit
(digital input 40 points, digital output 40 points).
This unit is fixed to ST#14.

7. Press [ENTER].

- The confirmation dialog box appears.

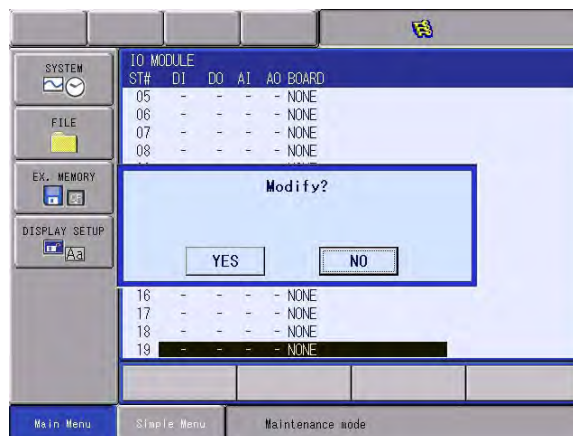

8. Select "YES."

- When the mounted status of an I/O module is correct, select "YES." The I/O module setting is updated, and an I/O module is added.

If the window does not indicate the actual mounted status, recheck the cable connection and the switch setting.

If the mounted status is correct (but the window does not correspond), the following causes are suspected.

- Improper I/O communication settings
The settings of JP1 and JP2 on the XOIO2B board may be incorrect, so the DX100 cannot recognize the board.
- Improper or overlapped station settings
S1 may be erroneously set to 0, E, or F. Each station can be set to only one board. If S1 has been set to two boards, change the setting of S1 so only one board is assigned.
- Improper connection of the 24 VDC power cable and the I/O communication cable
The 24 VDC cable and the I/O communication cable may not be connected properly. Recheck the cable connection referring to *Section 4.4 "Connecting Each Cable" on page 4-3*. Improper connection of the 24 VDC power cable to the CN02 may prevent the board from starting up.
- I/O module failure
When the above causes do not apply, and the display still does not correspond to the actual mounted status, failure of an I/O module is suspected. Contact your YASKAWA representative.



5.2 I/O Data

The data to be transferred from the XOI02B board to the inside of the DX100 is of 40 input points (5 bytes) and 40 output points (5 bytes). The I/O data of the XOI02B board is allocated to external I/O signals of concurrent I/O.

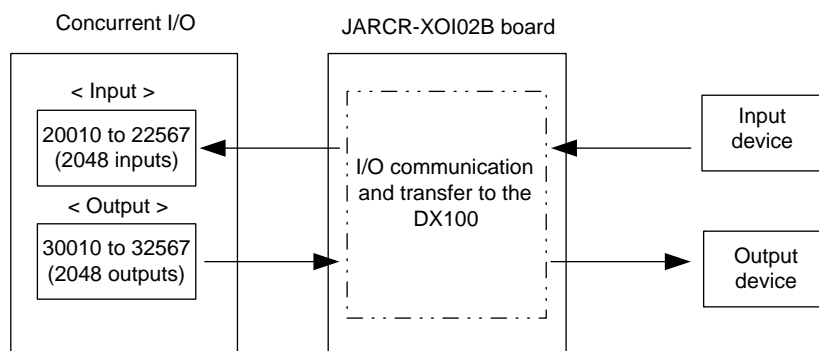

When only a XOI02B board is mounted as an optional I/O board, the concurrent I/O allocation of each board is as follows.

(20010 to 20057 and 30010 to 30057 are used for standard I/O of the DX100.)

Input	Output
20060 to 20067: CN12 20070 to 20073: CN12	30060 to 30067: CN12 30070 to 30073: CN12
20074 to 20077: CN13 20080 to 20083: CN13	30074 to 30077: CN13 30080 to 30087: CN13
20090 to 20097: CN10	30090 to 30097: CN10
20100 to 20107: CN11	30100 to 30107: CN11

6 I/O Circuits

NOTE

- When an internal power supply is used for the I/O power supply, the allocation to the 24 VDC internal power supply of the DX100 is approximately 1.5A. If the total current consumption of the I/O circuits including that of other I/O boards (such as the JZNC-YIU01-E unit) exceeds 1.5A, use an external power supply.
For connecting external power supply, refer to *Section 6.3 "Connection Example" on page 6-4.*
- When an external power supply is used for the I/O power supply and the total current consumption of the I/O circuits exceeds 2A, use a 24 VDC external power supply. However, do not use the 24 VDC power supply from CN10 and CN11 for the 24 VDC power supply used at the relay output contact.
- The I/O circuits of the XOI02B board are exclusive-use for 24 VDC. Connecting a power supply other than 24 VDC causes damages to the circuits and malfunction.

6.1 Input Circuit

The input circuit has 40-points, and all for input circuit 1.

6.1.1 Input Circuit 1 (CN10 to CN13)

Circuit structure	Input circuit with photocoupler insulation
Current (max.)	8 mA per one point
Common	+24 V common

Connection example

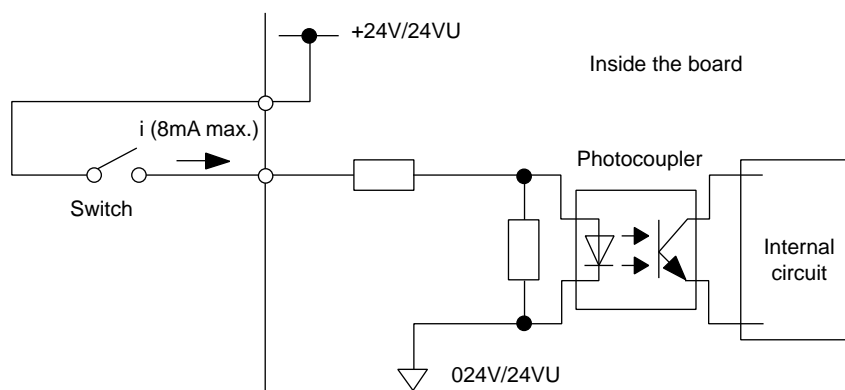

6.2 Output Circuits

The output circuit has 40 points from CN10 through CN13. Two types of circuits are provided: transistor output (24 points) and relay output (16 points). When the contact life of a relay should be considered because of frequent ON/OFF switchings, the transistor output can be used to control a relay mounted on an easily accessible position or a non-contact relay SSR (solid state relay).



When connecting an inductive load to the output circuit, connect a fly-wheel diode in parallel to the inductive load, to suppress the surge voltage. Not using a fly-wheel diode may damage the output circuit.

When connecting a load with a large inrush current such as a lamp, connect a current limiting resistance in series to the load, so that the output current does not exceed its maximum value. Exceeding the maximum output current value may damage the output circuit.

6.2.1 Output Circuit 1 CN12 and CN13 (Transistor Output)

Circuit structure	PNP transistor open-collector output
Output current (max.)	50 mA per one point
Common	0V common

Connection example

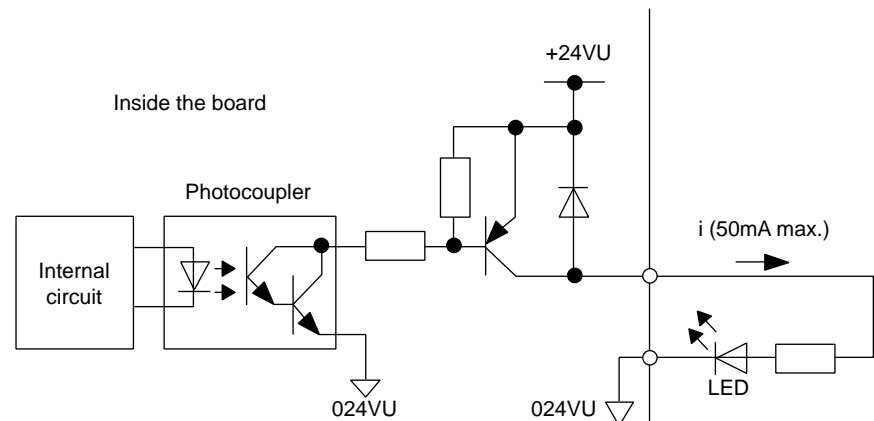

6.2.2 Output Circuit 2 CN10 and CN11 (Relay Output)

Circuit structure	Relay contact output (only DC load can be connected)
Output current (max.)	0.5A per point
Common	None (determined according to the external connection)
Contact resistance	30 mΩ or less
Min. applicable load for contact	0.1 VDC, 0.1 mA
Relay life	Electrical life: 300,000 times (with inductive load 24 VDC, 0.5A) Mechanical life: 20,000,000 times

Connection example

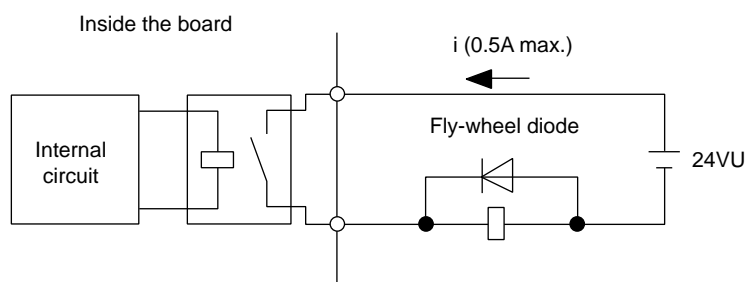

6.3 Connection Example

The following are allocation examples when the XOI02B board is added to the DX100: handling application; and arc welding, spot welding, and general-purpose applications. The "general-purpose applications" in this manual includes; assembling and cutting applications.

These examples are applied when only one XOI02B board is used as an optional I/O board. When any other optional I/O boards are added, the XOI02B board allocation will be changed depending on the I/O board allocation.

6.3.1 Handling Application

CN12 User input/output (for handling application)

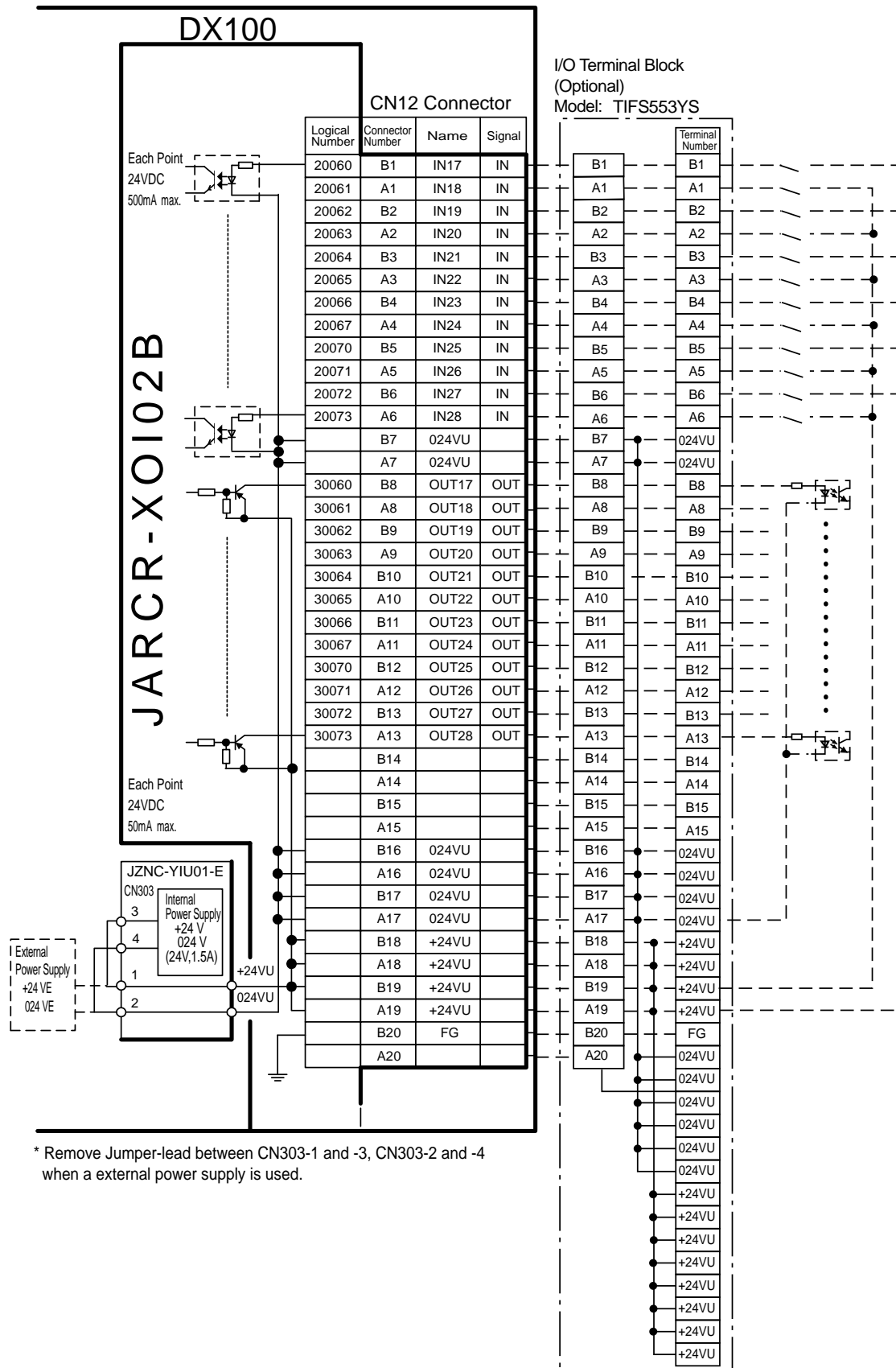

CN13 User input/output (for handling application)

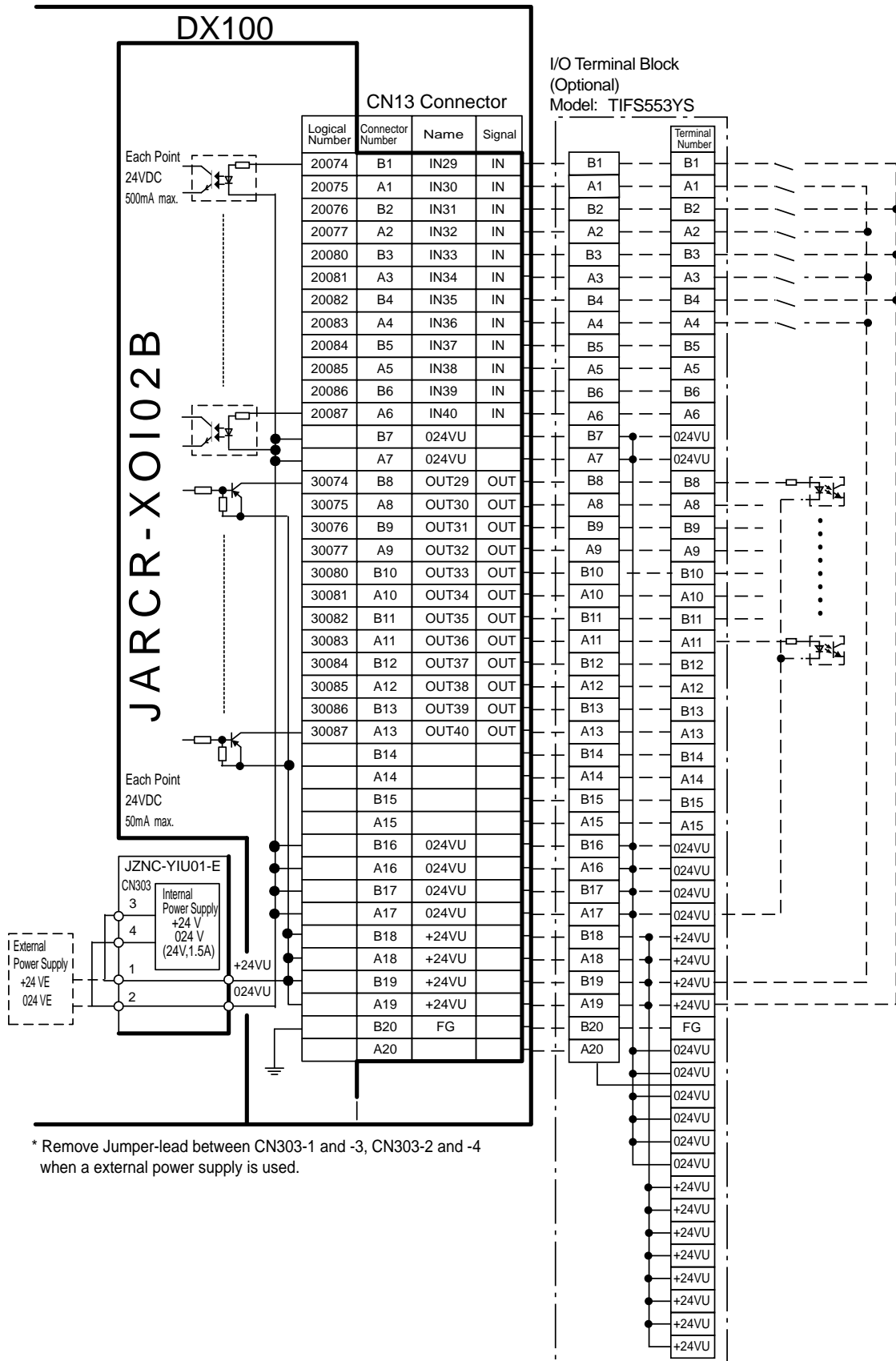

CN10 User input/output (for handling application)

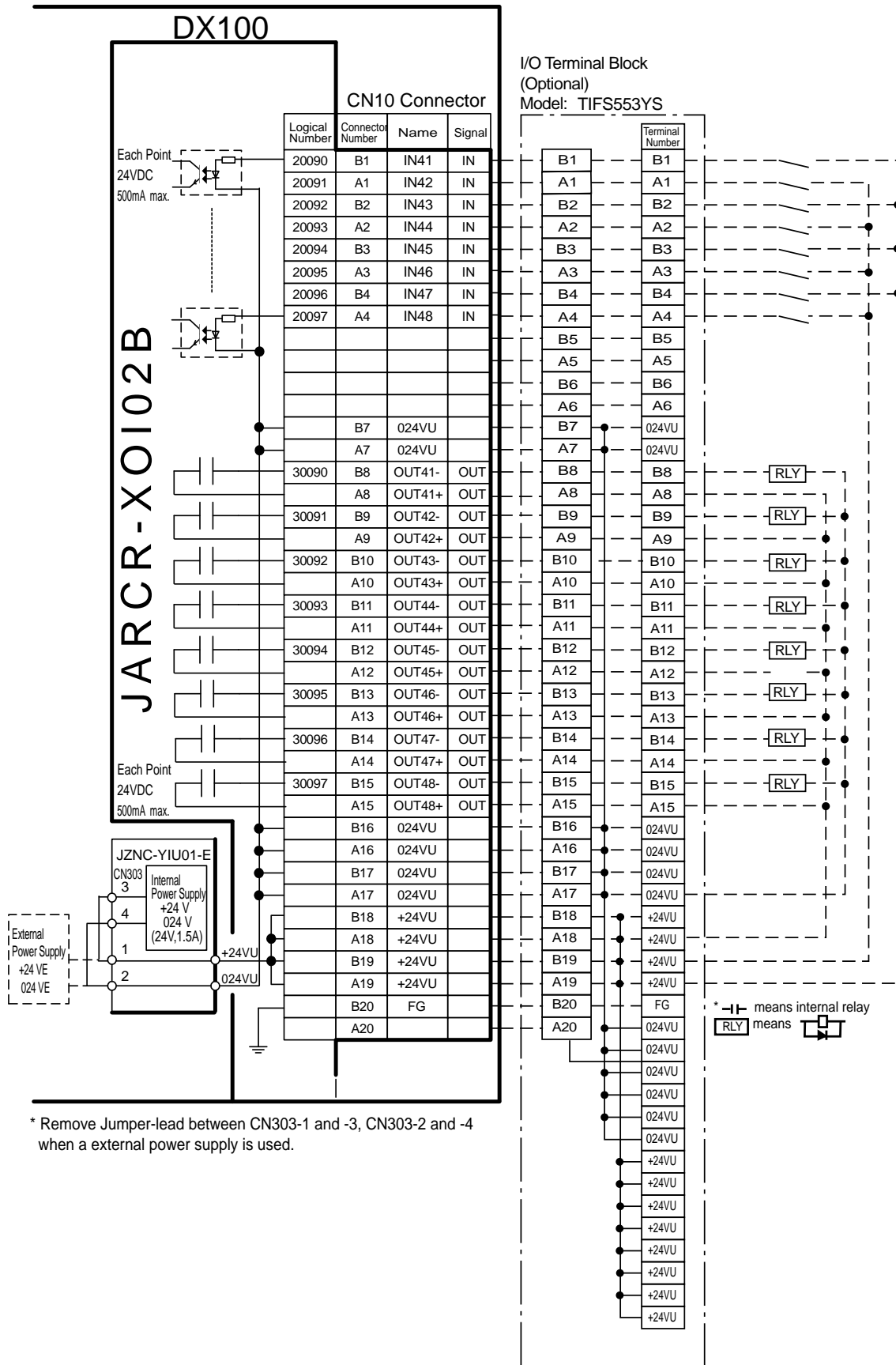

* Remove Jumper-lead between CN303-1 and -3, CN303-2 and -4 when an external power supply is used.

CN11 User input/output (for handling application)

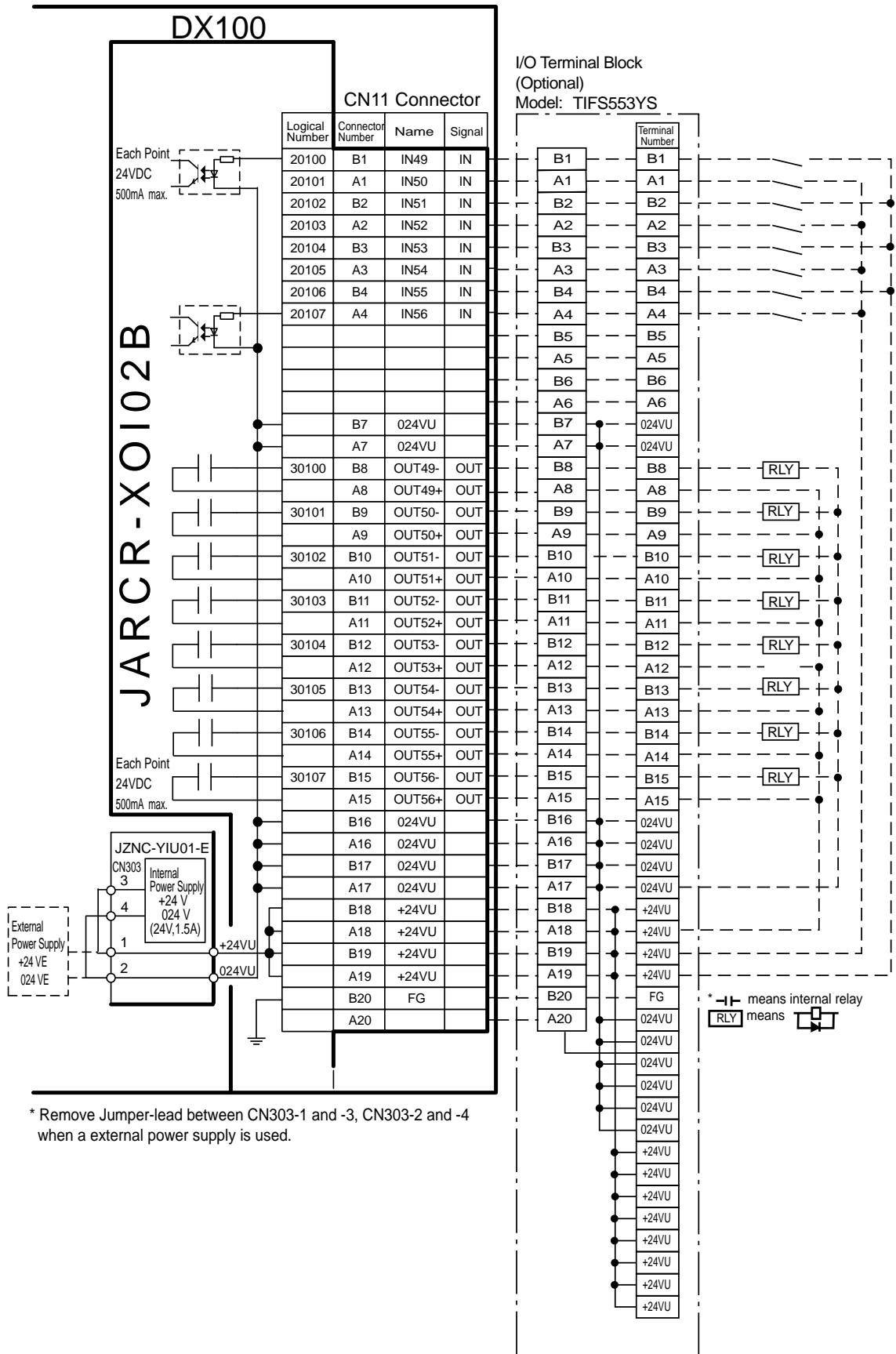

* Remove Jumper-lead between CN303-1 and -3, CN303-2 and -4 when an external power supply is used.

6.3.2 Arc Welding, Spot Welding, and General-Purpose Applications

CN12 User input/output
(for arc welding, spot welding, and general-purpose applications)

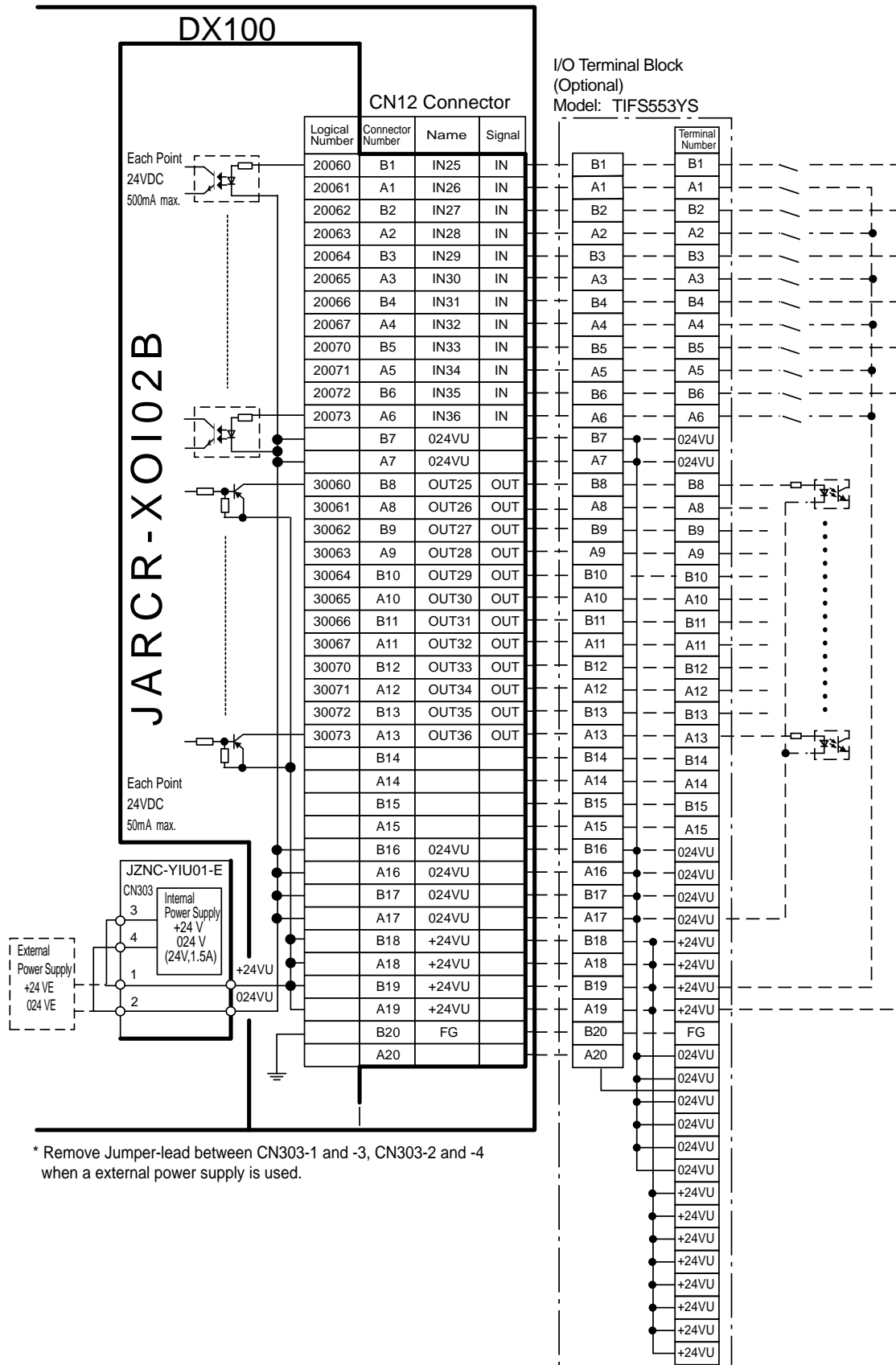

CN13 User input/output
(for arc welding, spot welding, and general-purpose applications)

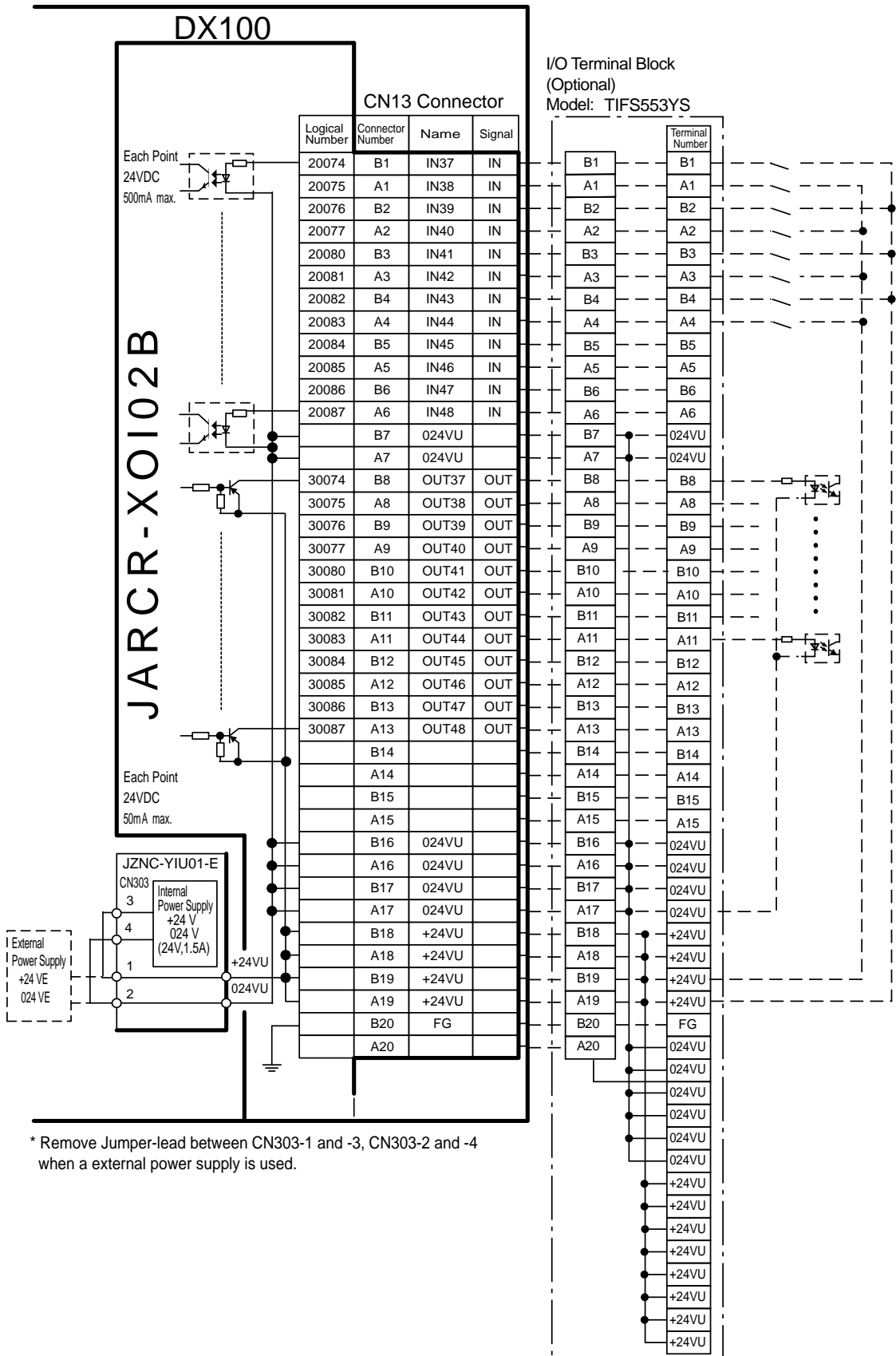

CN10 User input/output
(for arc welding, spot welding, and general-purpose applications)

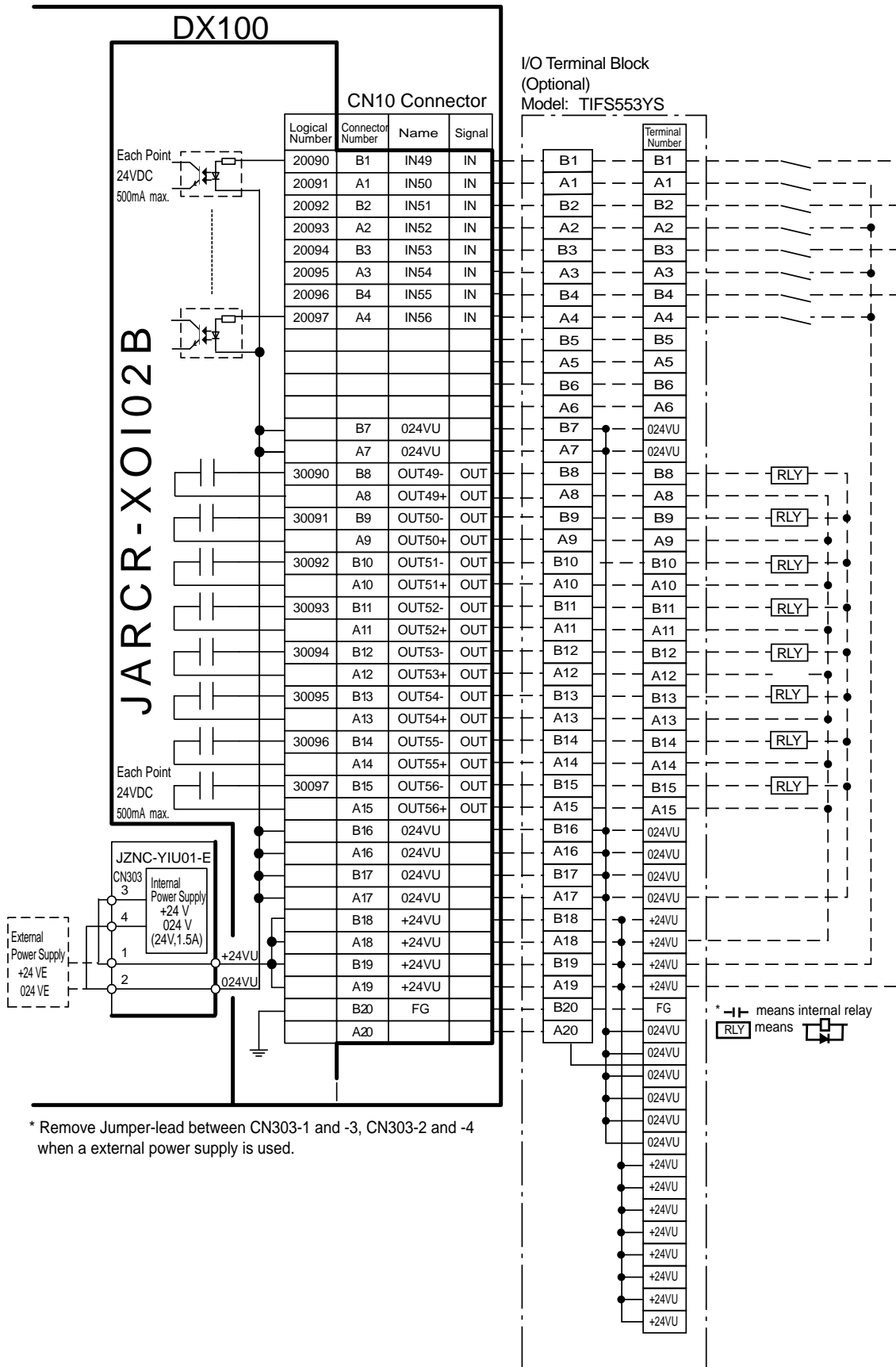

* Remove Jumper-lead between CN303-1 and -3, CN303-2 and -4 when a external power supply is used.

CN11 User input/output
(for arc welding, spot welding, and general-purpose applications)

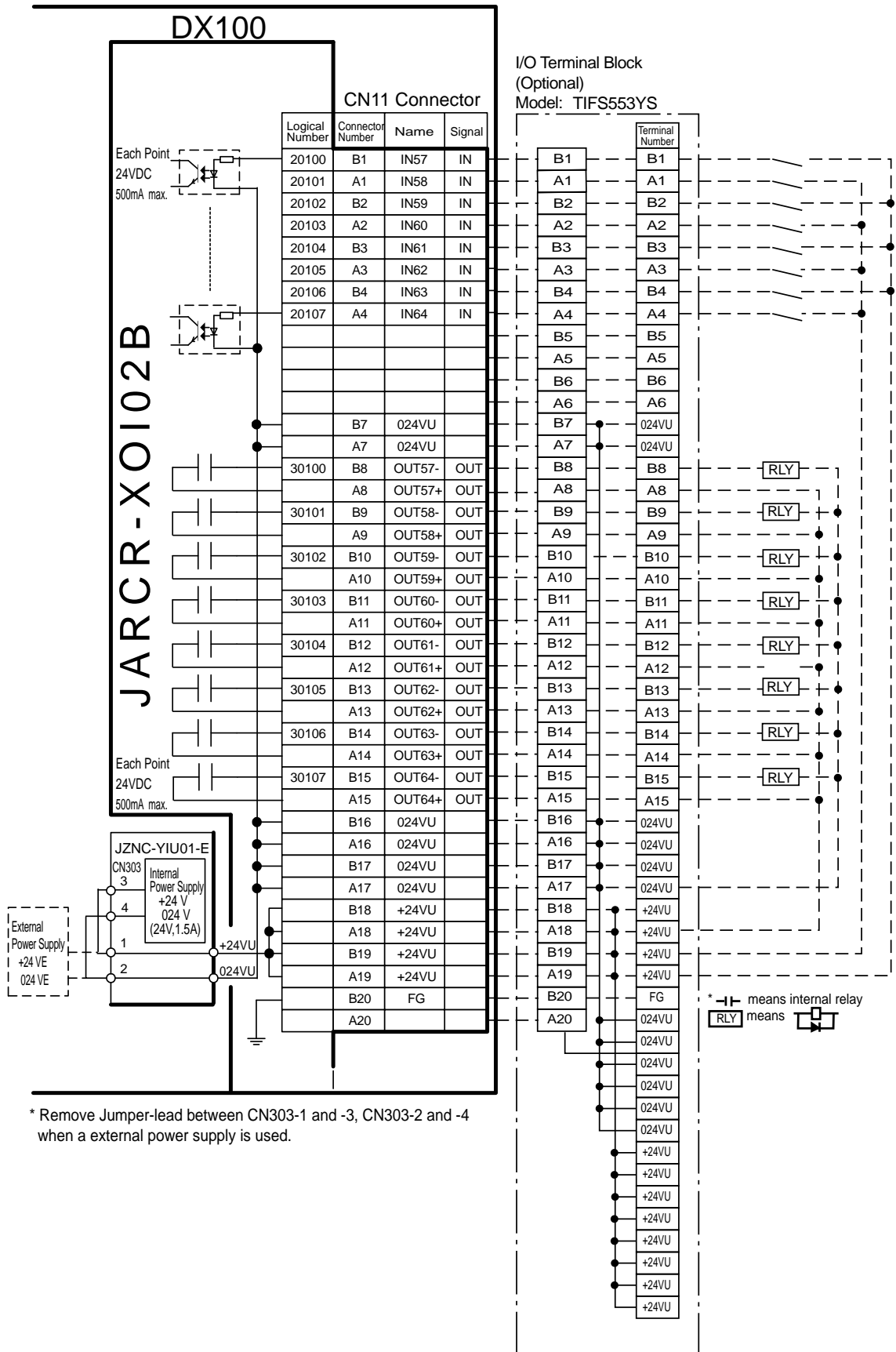

DX100 OPTIONS

JARCR-XOI02B BOARD INSTRUCTIONS

FOR I/O EXPANSION FOR EUROPEAN STANDARDS

HEAD OFFICE

2-1 Kurosakishiroishi, Yahatanishi-ku, Kitakyushu 806-0004, Japan
Phone +81-93-645-7745 Fax +81-93-645-7746

YASKAWA America Inc. M Robotics Division
100 Automation Way, Miamisburg, OH 45342, U.S.A.
Phone +1-937-847-6200 Fax +1-937-847-6277

YASKAWA Nordic AB
Box 504 Verkstadsgatan 2, PO Box 504 SE-385 25 Torsås, Sweden
Phone +46-480-417-800 Fax +46-486-414-10

YASKAWA Europe GmbH Robotics Div.
Yaskawastrasse 1, 85391 Allershausen, Germany
Phone +49-8166-90-0 Fax +49-8166-90-103

YASKAWA Electric Korea Co., Ltd
9F, KYOBO Securities Bldg., 26-4, Yeoido-Dong Yeounggeungpo-ku, Seoul, Korea
Phone +82-2-784-7844 Fax +82-2-784-8495

YASKAWA Electric (Singapore) PTE Ltd.
151 Lorong Chuan, #04-02A, New Tech Park, Singapore 556741
Phone +65-6282-3003 Fax +65-6289-3003

YASKAWA Electric (Thailand) Co., Ltd.
252/246, 4th Floor. Muang Thai-Phatra Office Tower II Rachadaphisek Road,
Huaykwang Bangkok, 10320, Thailand
Phone +66-2-693-2200 Fax +66-2-693-4200

YASKAWA Shougang Robot Co. Ltd.
1015, Boxuenan Rd. Maluzhen, Jiading District, Shanghai, China
Phone +86-21-5950-3521 Fax +86-20-3878-0651

YASKAWA ELECTRIC CHINA Co., Ltd.
12F Carlton Building, No. 21-42 Huanghe Road, Shanghai 200003, China
Phone +86-21-5385-2200 Fax +86-21-5385-3299

YASKAWA Robotics India Ltd.
#426, Udyog Vihar, Phase- IV, Gurgaon, Haryana, India
Phone +91-124-475-8500 Fax +91-124-475-8542

Specifications are subject to change without notice
for ongoing product modifications and improvements.