

FS100 OPTIONS INSTRUCTIONS

SUPPORT DOCUMENTATION FOR
MOTOFIT POWER SUPPLY BOX

Upon receipt of the product and prior to initial operation, read these instructions thoroughly, and retain for future reference.

MOTOMAN INSTRUCTIONS

- MOTOMAN-□□□ INSTRUCTIONS
- MOTOFIT INSTRUCTIONS
- FS100 INSTRUCTIONS
- FS100 OPERATOR'S MANUAL
- FS100 MAINTENANCE MANUAL

Part Number: 165600-1CD
Revision: 0



MANDATORY

- This manual explains setup, diagnosis, maintenance, hardware, etc. of the FS100 system. Read this manual carefully and be sure to understand its contents before handling the FS100.
- General items related to safety are listed in *chapter 1 "Safety" at page 1-1*. To ensure correct and safe operation, carefully read the chapter.



CAUTION

- Some drawings in this manual are shown with the protective covers or shields removed for clarity. Be sure all covers and shields are replaced before operating this product.
- The drawings and photos in this manual are representative examples and differences may exist between them and the delivered product.
- YASKAWA may modify this model without notice when necessary due to product improvements, modifications, or changes in specifications. If such modification is made, the manual number will also be revised.
- If your copy of the manual is damaged or lost, contact a YASKAWA representative to order a new copy. The representatives are listed on the back cover. Be sure to tell the representative the manual number listed on the front cover.
- YASKAWA is not responsible for incidents arising from unauthorized modification of its products. Unauthorized modification voids your product's warranty.

Notes for Safe Operation

Read this manual carefully before installation, operation, maintenance, or inspection of the FS100.

In this manual, the Notes for Safe Operation are classified as "WARNING", "CAUTION", "MANDATORY" or "PROHIBITED".



WARNING

Indicates a potentially hazardous situation which, if not avoided, could result in death or serious injury to personnel.



CAUTION

Indicates a potentially hazardous situation which, if not avoided, could result in minor or moderate injury to personnel and damage to equipment. It may also be used to alert against unsafe practices.



MANDATORY

Always be sure to follow explicitly the items listed under this heading.



PROHIBITED

Must never be performed.

Even items described as "CAUTION" may result in a serious accident in some situations.

At any rate, be sure to follow these important items.



To ensure safe and efficient operation at all times, be sure to follow all instructions, even if not designated as "CAUTION" and "WARNING".



WARNING

- Confirm that no person is present in the manipulator's operating range and that you are in a safe location before:
 - Turning ON the FS100 power.
 - Moving the manipulator with the programming pendant.
 - Running the system in the check mode.
 - Performing automatic operations.

Injury may result if anyone enters the manipulator's operating range during operation. Always press the emergency stop button immediately if there is a problem. The emergency stop button is located on the right of the programming pendant.

- Observe the following precautions when performing teaching operations within the manipulator's operating range:
 - View the manipulator from the front whenever possible.
 - Always follow the predetermined operating procedure.
 - Keep in mind the emergency response measures against the manipulator's unexpected motion toward you.
 - Ensure that you have a safe place to retreat in case of emergency.

Improper or unintended manipulator operation may result in injury.

- Before operating the manipulator, check that servo power is turned OFF when the emergency stop button on the programming pendant is pressed. When the servo power is turned OFF, the SERVO ON LED on the programming pendant is turned OFF.

Injury or damage to machinery may result if the emergency stop circuit cannot stop the manipulator during an emergency. The manipulator should not be used if the emergency stop button does not function.

Fig. : Emergency Stop Button



- In the case of not using the programming pendant, be sure to supply the emergency stop button on the equipment. Then before operating the manipulator, check to be sure that the servo power is turned OFF by pressing the emergency stop button. Connect the external emergency stop button to the 5-6 pin and 16-17 pin of the robot system signal connector (CN2).
- Upon shipment of the FS100, this signal is connected by a jumper cable in the dummy connector. To use the signal, make sure to supply a new connector, and then input it.

If the signal is input with the jumper cable connected, it does not function, which may result in personal injury or equipment damage.



WARNING

- Once the emergency stop button is released, clear the cell of all items which could interfere with the operation of the manipulator. Then turn the servo power ON.

Injury may result from unintentional or unexpected manipulator motion.

Fig. : Release of Emergency Stop



CAUTION

- Perform the following inspection procedures prior to conducting manipulator teaching. If a problem is found, correct it and take all other necessary actions immediately.
 - Check for problems in manipulator movement.
 - Check for damage to insulation and sheathing of external wires.
- Return the programming pendant to a safe place after use.

If the programming pendant is inadvertently left on the manipulator, on a fixture, or on the floor, the manipulator or a tool may collide with the programming pendant during manipulator movement, which may result in personal injury or equipment damage.

- Read and understand the Explanation of the Warning Labels before operating the manipulator.

Explanation of Warning Labels

The following warning labels are attached to the manipulator and FS100.
Fully comply with the precautions on the warning labels.



WARNING

- The label described below is attached to the manipulator.

Observe the precautions on the warning labels.

- Failure to observe this caution may result in injury or damage to equipment.





Refer to the manipulator manual for the warning label location.

- The following warning labels are attached to FS100.

Observe the precautions on the warning labels.

Failure to observe this warning may result in injury or damage to equipment.

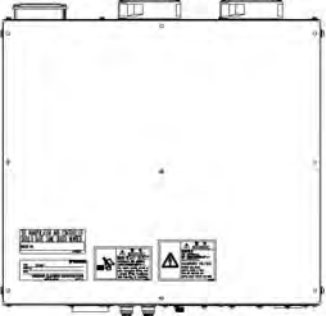

Top View



Heavy Object Warning NP

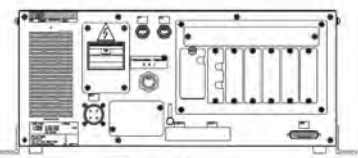

Front View



Electric Shock Warning NP



Electric Shock Warning NP

Read and understand the FS100 before operating the MotoFit Power-Supply Box.
Refer to FS100 Operation Manual (159644-1CD).

1. Composition of FS100	1-1
1.1 Outline View.....	1-1
1.2 Arrangement Plan	1-2
1.3 Wiring Diagram	1-3
2. The Notes by the Installation Method	2-1
2.1 Single Controller	2-1
2.2 Multi-Controller.....	2-2
3. Failure Diagnosis.....	3-1
4. Exchange Method.....	4-1
5. Use Apparatus List (Recommended Spare Parts).....	5-1

1. Composition of FS100

1.1 Outline View

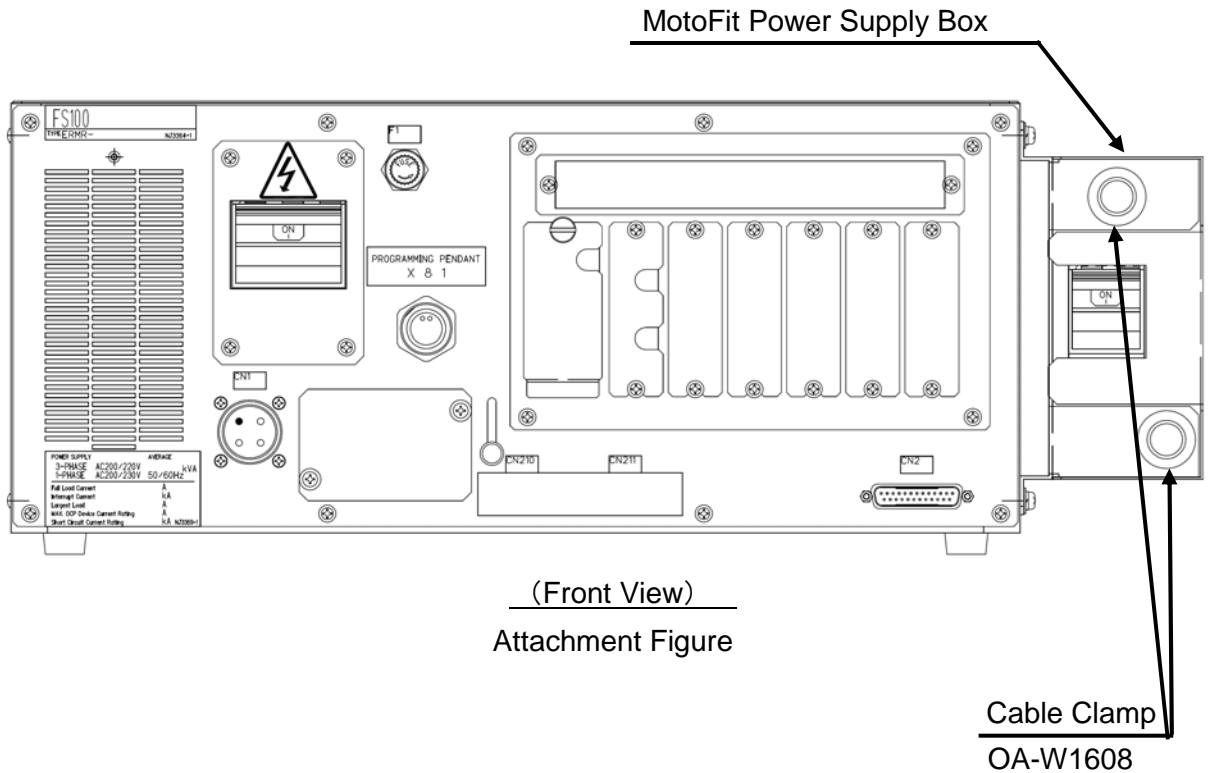

(Front View)
Attachment Figure

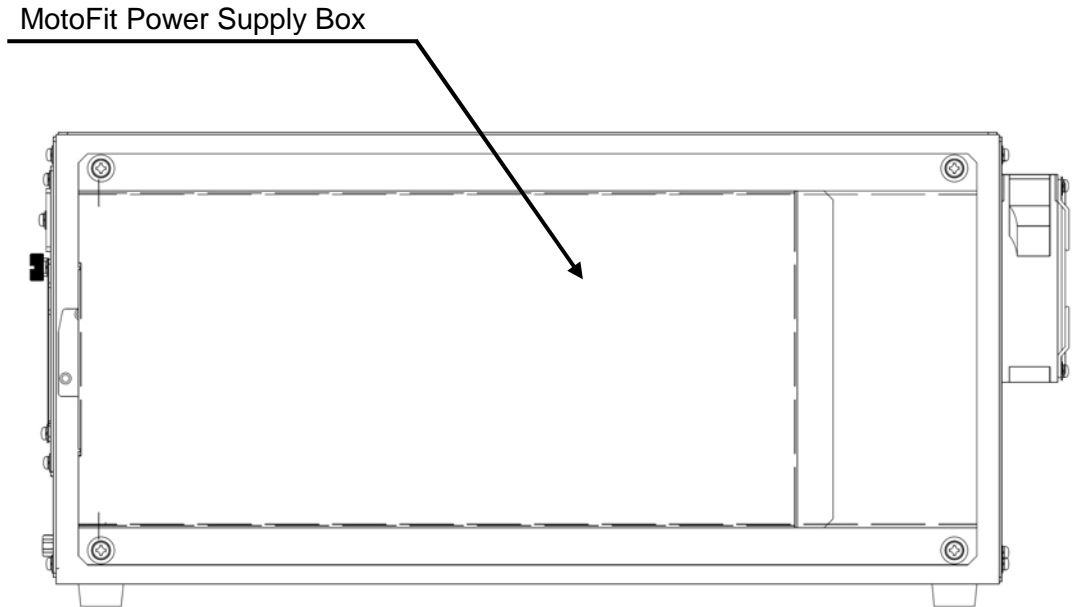

(Right Side View)
Attachment Figure

1.2 Arrangement Plan

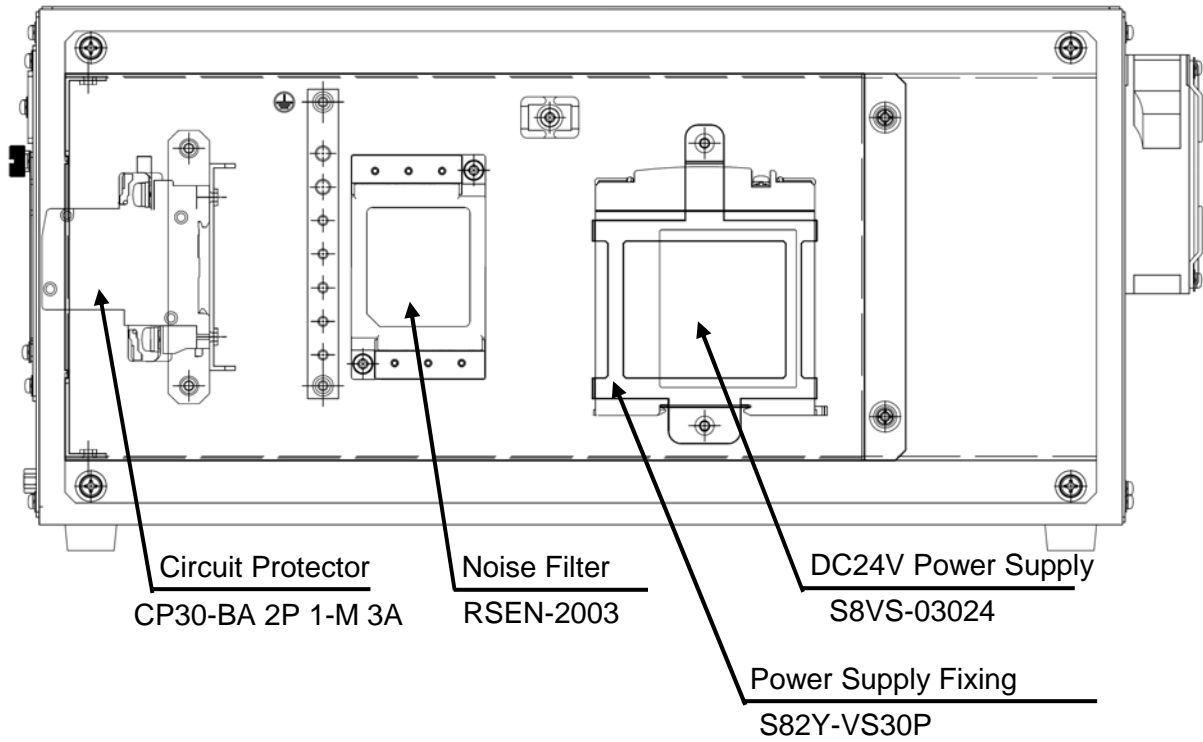

(Right Side View)
Internal Alignment Figure

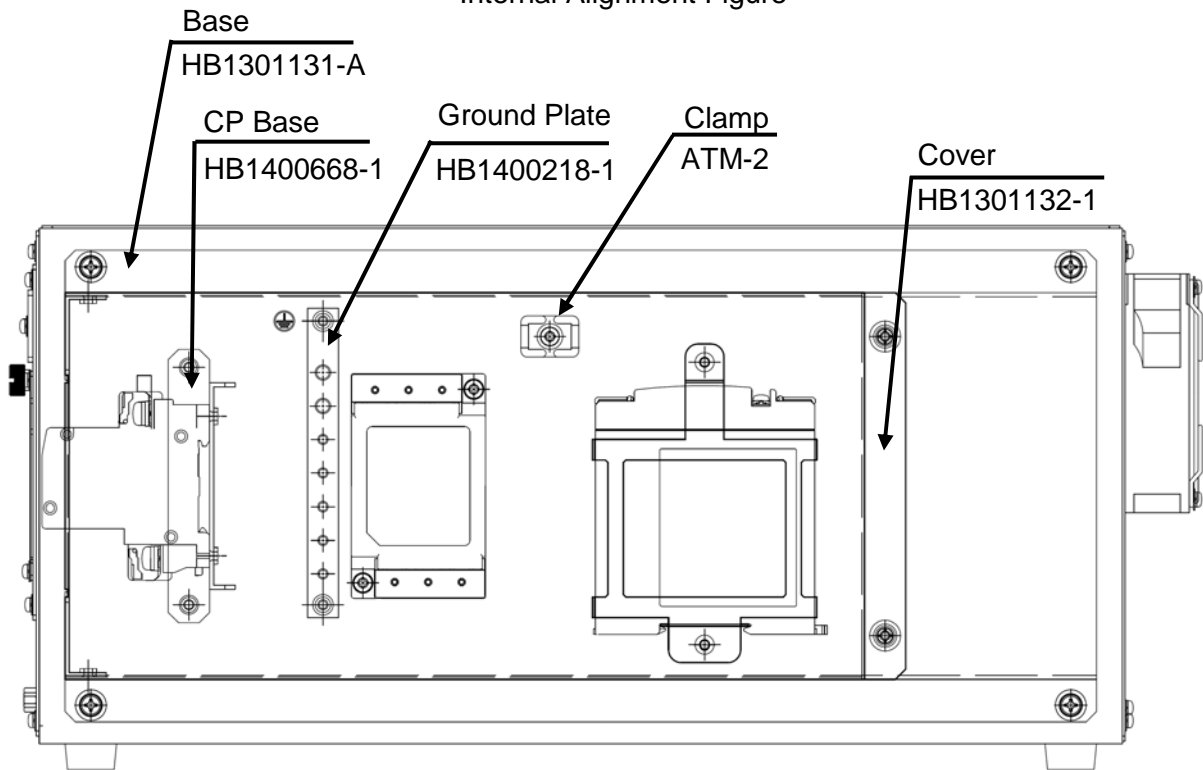

(Right Side View)
Internal Alignment Figure

1.3 Wiring diagram

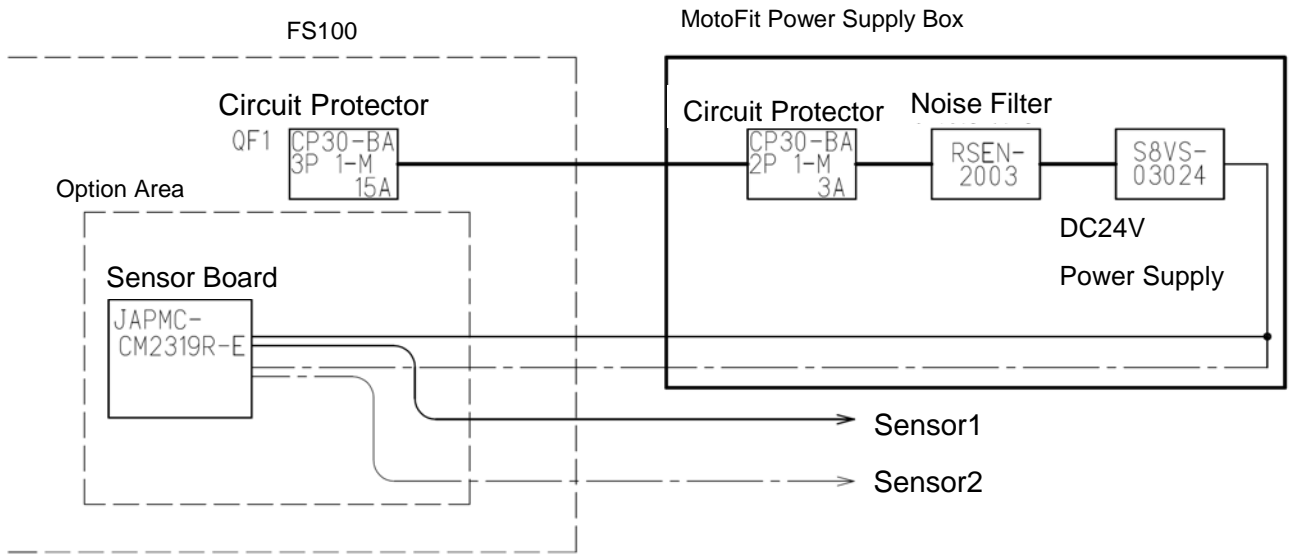

Wiring Diagram

2. The Notes by the Installation Method

2.1 Single-arm Robot Controller

The MotoFit Power Supply Box can be used with width and length. Turning the MotoFit power supply box turns the case of every length up.

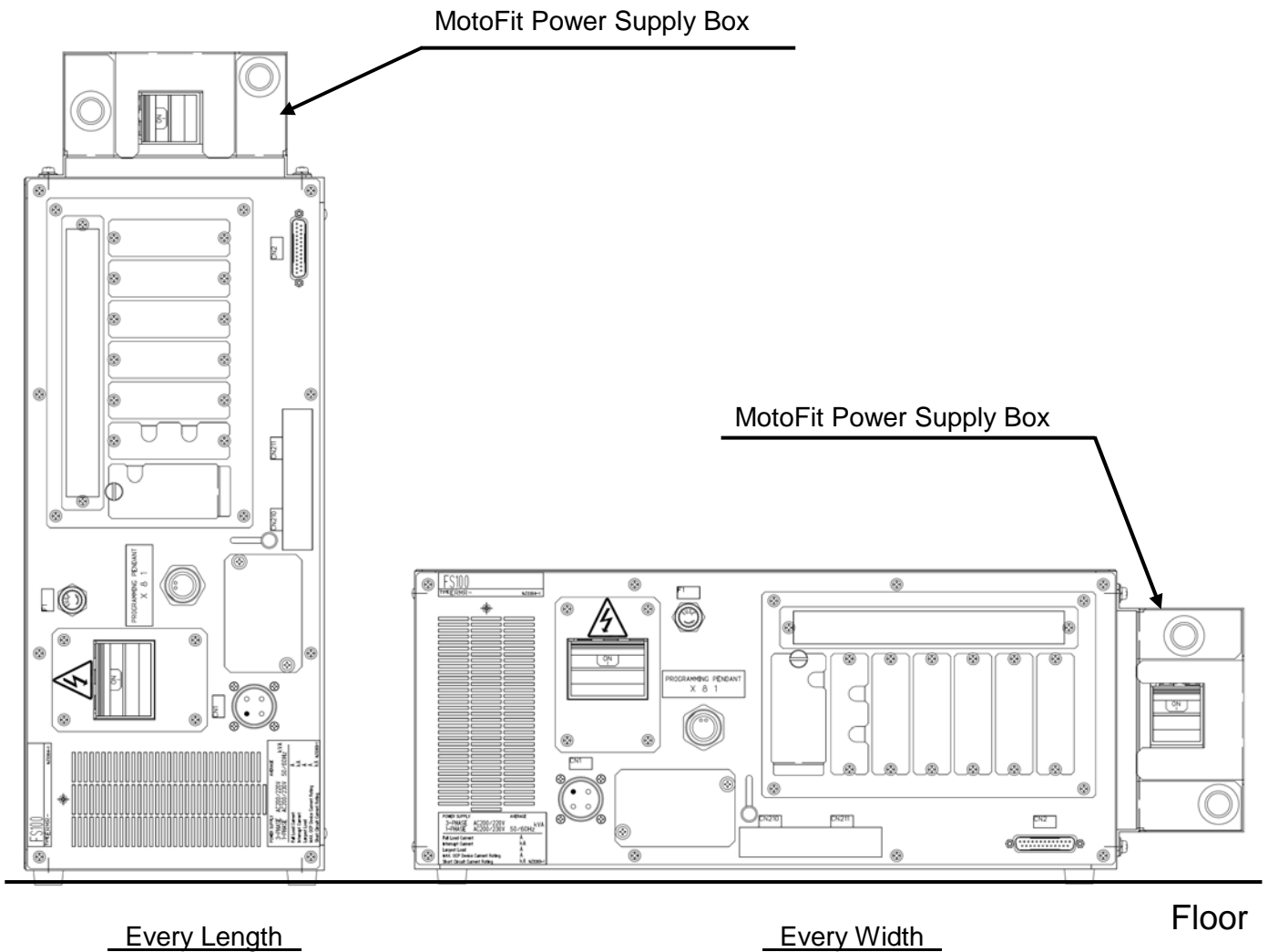

2.2 Dual-arm Robot Controller

It can be used by every side. (SDA**F controller)

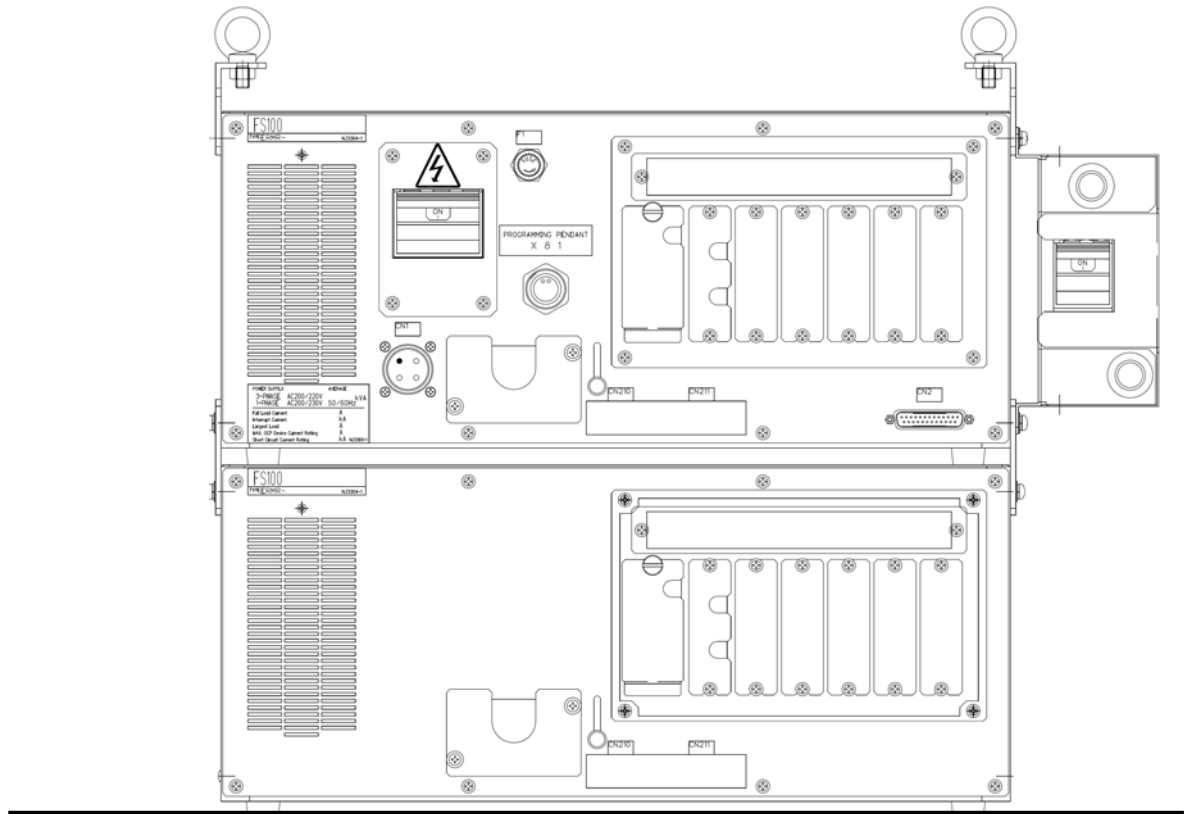

Every Width

3. Failure Diagnosis

Please give me the following correspondence according to the phenomenon of failure.
Please refer to an operation manual (159644-1CD) for operation of FS100.

Condition	Cause	The correspondence method
The force sensor does not operate.	The circuit protector of the MOTOFIT power supply BOX is come by off.	Please turn ON the circuit protector of the MOTOFIT power supply BOX.
	The poor connector connection to a sensor board output.	Please check connection of the output connector of a sensor board.
	Poor insertion of a sensor board.	Please insert a sensor board certainly.
	Failure of a sensor board.	Please exchange a sensor board.
	Failure of DC24V power supply.	Please exchange DC24V power supply.



CAUTION

There is fear of an electric shock and an injury.

- The specified person needs to perform maintenance and check.

4. Exchange method



CAUTION

Turn OFF the circuit protector on the FS100 and the MotoFit power supply before working on the FS100 or the MotoFit power supply box.

Failure to turn OFF the circuit protectors may cause electric shock and an injury.

If four screws of the MotoFit power supply box are removed, a cover will come off.

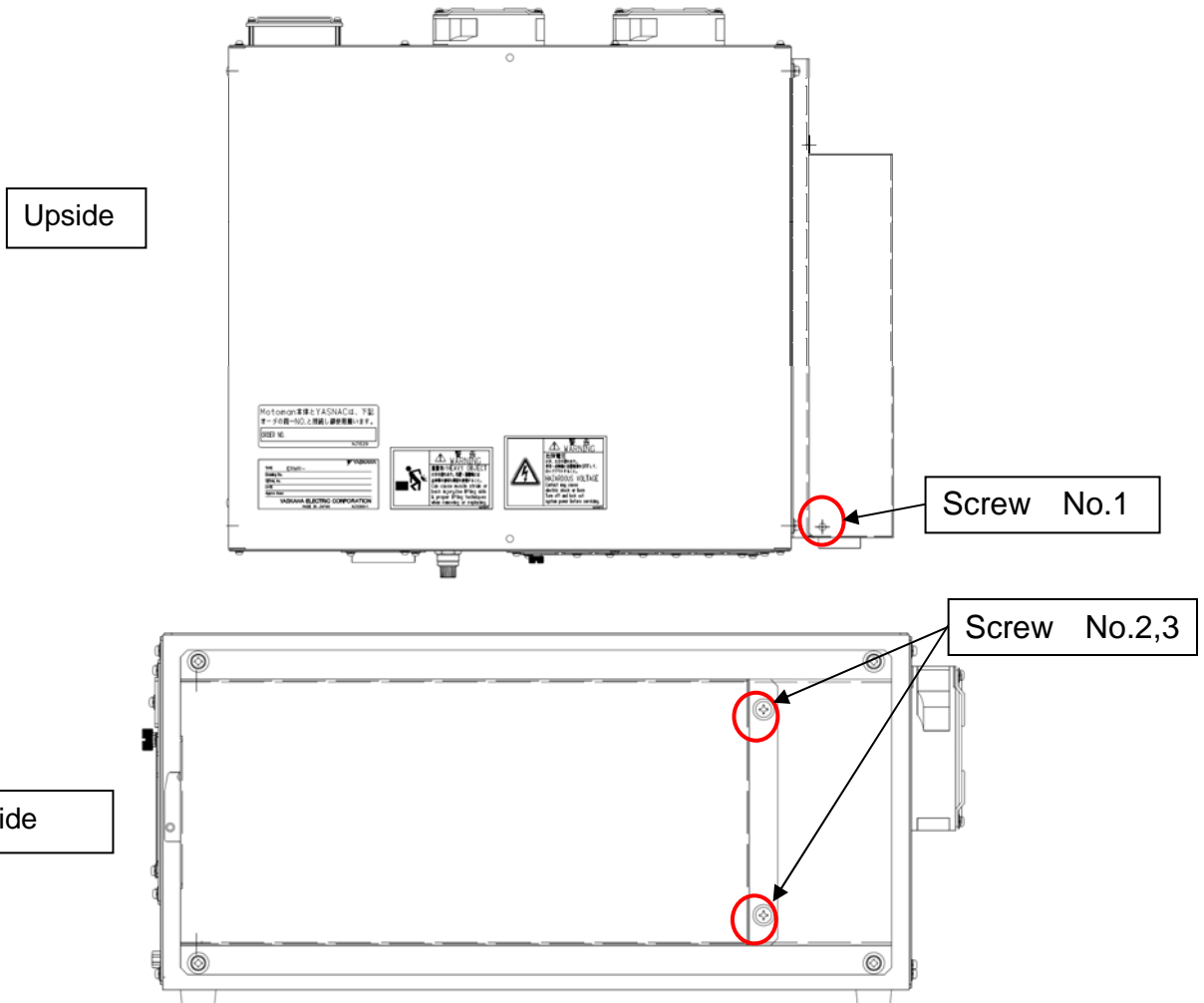

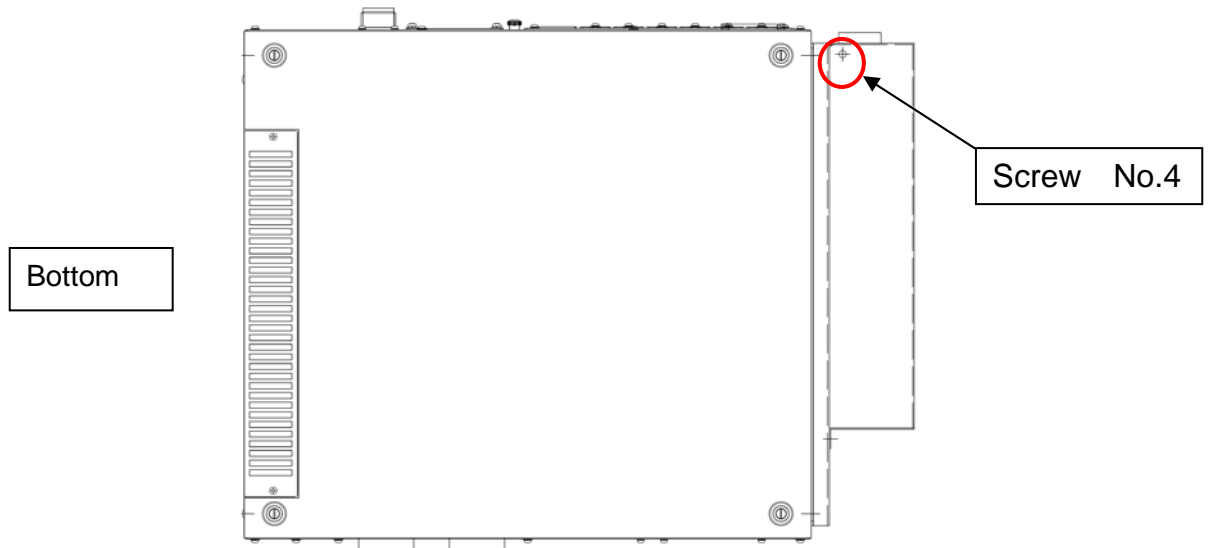

1. Remove cover and exchange internal apparatus.
2. Remove the wiring connected to the parts to exchange.
3. Prepare parts and attach parts and wiring connection.
4. Attach cover after checking wiring.

 The marks shown in the following figures indicate where to attach screws.

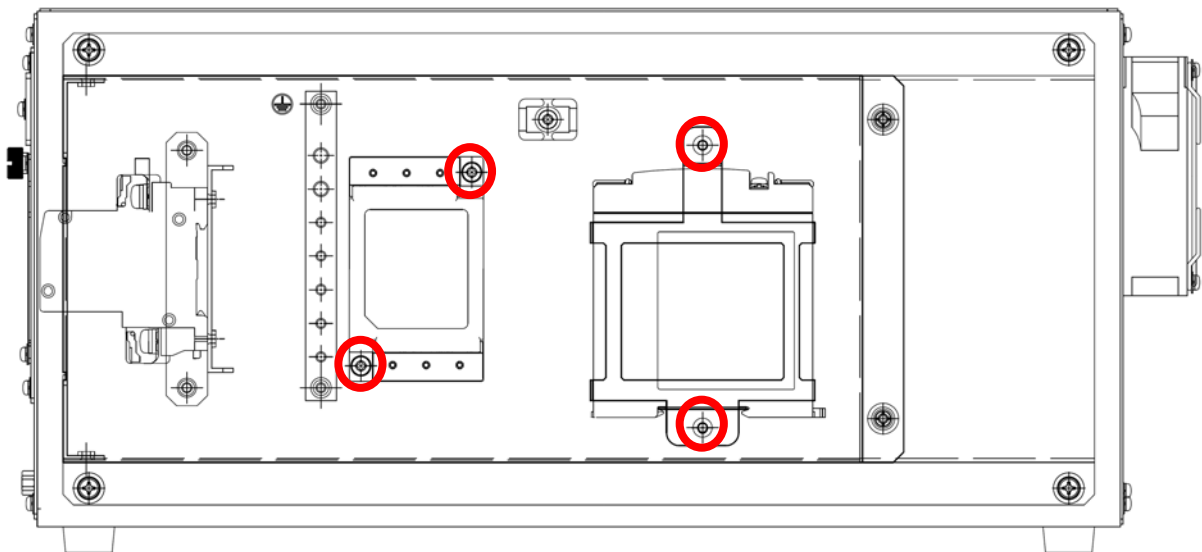

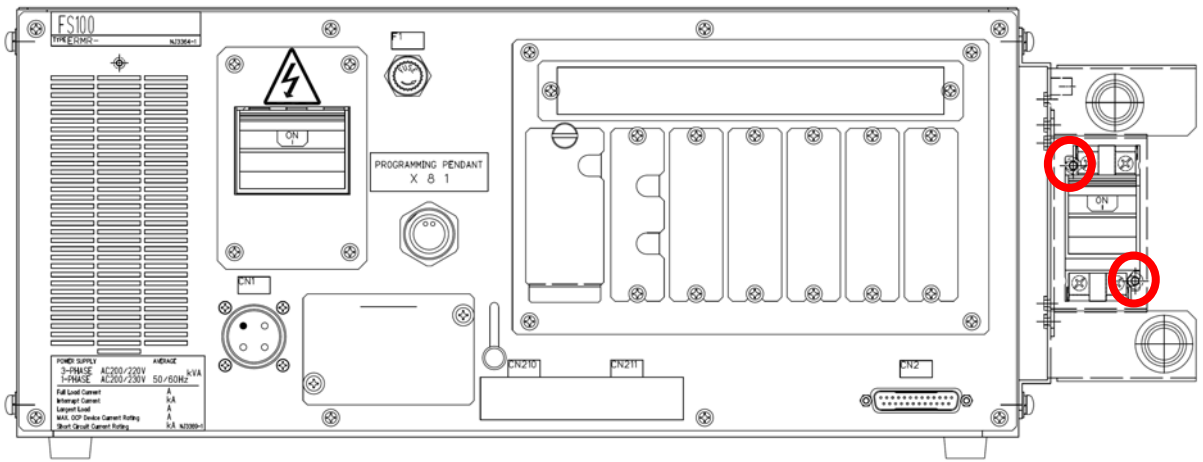

5. Use Apparatus List (Recommended Spare Parts)

The electric part used for the MotoFit power supply box is as follows.

Rank	Name	Model	Manufacturer	Note
A	DC24V Power Supply	S8VS-03024	OMRON	
B	Circuit Protector	CP30-BA 2P 1-M 3A	MITSUBISHI	
B	Noise Filter	RSEN-2003	TDK Lamda	

- Rank A : The thing of exchange frequency expected to be comparatively large
- Rank B : The thing of exchange frequency expected to be comparatively small

FS100 OPTIONS INSTRUCTIONS

SUPPORT DOCUMENTATION FOR
MOTOFIT POWER SUPPLY BOX

HEAD OFFICE

2-1 Kurosakishiroishi, Yahatanishi-ku, Kitakyushu 806-0004 Japan
Phone +81-93-645-7745 Fax +81-93-645-7746

YASKAWA America Inc. MOTOMAN Robotics Division
100 Automation Way, Miamisburg, OH 45342, U.S.A.
Phone +1-937-847-6200 Fax +1-937-847-6277

YASKAWA Nordic AB
Verkstadsgatan 2, PO Box 504, SE-385 25 Torsås, Sweden
Phone +46-480-417-800 Fax +46-486-414-10

YASKAWA Europe GmbH Robotics Div.
Kammerfeldstr. 1, 80591 Allershausen, Germany
Phone +49-8166-90-0 Fax +49-8166-90-103

YASKAWA Electric Korea Co., Ltd
9F, KYOBO Securities Bldg., 26-4, Yeoido-Dong Yeoungpo-ku, Seoul, KOREA
Phone +82-2-784-7844 Fax +82-2-784-8495

YASKAWA Electric (Singapore) PTE Ltd.
151 Lorong Chuan, #04-02A, New Tech Park, Singapore 556741
Phone +65-6282-3003 Fax +65-6289-3003

YASKAWA Electric (Thailand) Co., Ltd.
252/246, 4th Floor, Muang Thai-Phatra Office Tower II Rachadaphisek Road, Huaykwang Bangkok, 10320 Thailand
Phone +66-2-693-2200 Fax +66-2-693-4200

YASKAWA Shougang Robot Co. Ltd.
No.7, Yongchang-North Road, Beijing E&T Development Area, China 100176
Phone +86-10-6788-0548 Fax +86-10-6788-0548-813

YASKAWA ELECTRIC (SHANGHAI) Co., Ltd.
No.18Xizang Zhong Road, 17F, Harbour Ring Plaza, Shanghai 200001, CHINA
Phone +86-21-5385-0655 Fax +86-21-5385-2770

YASKAWA Robotics India Ltd.
#426, Udyog Vihar, Phase- IV, Gurgaon, Haryana, India
Phone +91-124-475-8500 Fax +91-124-414-8016

Specifications are subject to change without notice
for ongoing product modifications and improvements.