

# DX200 OPTIONS INSTRUCTIONS

FOR I/O OUTPUT TIMING CONTROL FUNCTION

---

Upon receipt of the product and prior to initial operation, read these instructions thoroughly, and retain for future reference.

---

## MOTOMAN INSTRUCTIONS

MOTOMAN-□□□ INSTRUCTIONS  
DX200 INSTRUCTIONS  
DX200 OPERATOR'S MANUAL  
DX200 MAINTENACE MANUAL

The DX200 operator's manual above corresponds to specific usage.  
Be sure to use the appropriate manual.

Part Number: 165473-1CD  
Revision: 0



## MANDATORY

- This manual explains the I/O output timing control function of the DX200 system. Read this manual carefully and be sure to understand its contents before handling the DX200.
- General items related to safety are listed in the Chapter 1: Safety of the DX200 Instructions. To ensure correct and safe operation, carefully read the DX200 Instructions before reading this manual.



## CAUTION

- Some drawings in this manual are shown with the protective covers or shields removed for clarity. Be sure all covers and shields are replaced before operating this product.
- The drawings and photos in this manual are representative examples and differences may exist between them and the delivered product.
- YASKAWA may modify this model without notice when necessary due to product improvements, modifications, or changes in specifications. If such modification is made, the manual number will also be revised.
- If your copy of the manual is damaged or lost, contact a YASKAWA representative to order a new copy. The representatives are listed on the back cover. Be sure to tell the representative the manual number listed on the front cover.
- YASKAWA is not responsible for incidents arising from unauthorized modification of its products. Unauthorized modification voids your product's warranty.

## Notes for Safe Operation

Read this manual carefully before installation, operation, maintenance, or inspection of the DX200.

In this manual, the Notes for Safe Operation are classified as “WARNING”, “CAUTION”, “MANDATORY”, or “PROHIBITED”.



### WARNING

Indicates a potentially hazardous situation which, if not avoided, could result in death or serious injury to personnel.



### CAUTION

Indicates a potentially hazardous situation which, if not avoided, could result in minor or moderate injury to personnel and damage to equipment. It may also be used to alert against unsafe practices.



### MANDATORY

Always be sure to follow explicitly the items listed under this heading.



### PROHIBITED

Must never be performed.

Even items described as “CAUTION” may result in a serious accident in some situations. At any rate, be sure to follow these important items.



To ensure safe and efficient operation at all times, be sure to follow all instructions, even if not designated as “CAUTION” and “WARNING”.



## WARNING

- Before operating the manipulator, check that servo power is turned OFF when the emergency stop buttons on the front door of the DX200 and the programming pendant are pressed. When the servo power is turned OFF, the SERVO ON LED on the programming pendant is turned OFF.

Injury or damage to machinery may result if the emergency stop circuit cannot stop the manipulator during an emergency. The manipulator should not be used if the emergency stop buttons do not function.

*Figure 1: Emergency Stop Button*



- Once the emergency stop button is released, clear the cell of all items which could interfere with the operation of the manipulator. Then turn the servo power ON.

Injury may result from unintentional or unexpected manipulator motion.

*Figure 2: Release of Emergency Stop*

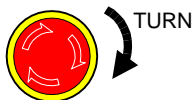

- Observe the following precautions when performing teaching operations within the P-point maximum envelope of the manipulator:
  - View the manipulator from the front whenever possible.
  - Always follow the predetermined operating procedure.
  - Keep in mind the emergency response measures against the manipulator's unexpected motion toward you.
  - Ensure that you have a safe place to retreat in case of emergency.

Improper or unintended manipulator operation may result in injury.

- Confirm that no person is present in the P-point maximum envelope of the manipulator and that you are in a safe location before:
  - Turning ON the DX200 power
  - Moving the manipulator with the programming pendant
  - Running the system in the check mode
  - Performing automatic operations

Injury may result if anyone enters the P-point maximum envelope of the manipulator during operation. Always press an emergency stop button immediately if there is a problem. The emergency stop buttons are located on the right of the front door of the DX200 and the programming pendant.

**CAUTION**

- Perform the following inspection procedures prior to conducting manipulator teaching. If problems are found, repair them immediately, and be sure that all other necessary processing has been performed.
  - Check for problems in manipulator movement.
  - Check for damage to insulation and sheathing of external wires.
- Always return the programming pendant to the hook on the DX200 cabinet after use.

The programming pendant can be damaged if it is left in the manipulator's work area, on the floor, or near fixtures.

- Read and understand the Explanation of the Warning Labels in the DX200 Instructions before operating the manipulator.

## Definition of Terms Used Often in This Manual

The MOTOMAN is the YASKAWA industrial robot product.

The MOTOMAN usually consists of the manipulator, the controller, the programming pendant, and supply cables.

In this manual, the equipment is designated as follows:

<b>Equipment</b>	<b>Manual Designation</b>
DX200 controller	DX200
DX200 programming pendant	Programming pendant
Cable between the manipulator and the controller	Manipulator cable

## I/O Output Timing Control

Descriptions of the programming pendant keys, buttons, and displays are shown as follows:

Equipment		Manual Designation
Programming Pendant	Character Keys	The keys which have characters printed on them are denoted with [ ]. ex. [ENTER]
	Symbol Keys	The keys which have a symbol printed on them are not denoted with [ ] but depicted with a small picture.  ex. page key  The cursor key is an exception, and a picture is not shown.
	Axis Keys Numeric Keys	“Axis Keys” and “Numeric Keys” are generic names for the keys for axis operation and number input.
	Keys pressed simultaneously	When two keys are to be pressed simultaneously, the keys are shown with a “+” sign between them, ex. [SHIFT]+[COORD]
	Displays	The menu displayed in the programming pendant is denoted with { }. ex. {JOB}

## Description of the Operation Procedure

In the explanation of the operation procedure, the expression "Select ●●●" means that the cursor is moved to the object item and the SELECT key is pressed, or that the item is directly selected by touching the screen.

## Registered Trademark

In this manual, names of companies, corporations, or products are trademarks, registered trademarks, or brand names for each company or corporation. The indications of (R) and <sup>TM</sup> are omitted.

---

1	About I/O Output Timing Control Function.....	1-1
2	Setup of I/O Output Timing Control Function.....	2-1
2.1	Instruction of I/O Output Timing Control Function .....	2-1
2.1.1	Configuration of Synchronized Signal Output Instruction.....	2-1
2.1.2	Configuration of +DOUT Instruction .....	2-2
2.1.3	Registration of +DOUT Instruction .....	2-4
2.1.4	Configuration of +PULSE Instruction.....	2-8
2.1.5	Registration of +PULSE Instruction.....	2-10
2.2	Device Response Delay Time Compensate Parameter .....	2-14
2.3	Signal Output Control Parameter During the FWD Operation.....	2-14
2.4	Notes .....	2-14
2.5	The Examples of the I/O Output Timing Specifying Function .....	2-15

# 1 About I/O Output Timing Control Function

I/O output timing control function is a function that can adjust the timing of general output signal by distance or time which based on the teaching position for the move instruction.

When the manipulator reaches to the specifying point which specified the time or distance while the manipulator is operating the move instruction, this function can output the general output signal. This function can adjust to deviation of work timing from the operation delay of the manipulator or devices which controlled by general output signal such as, valve and cylinder. Therefore, the manipulator can operate correctly, when it reaches to the expected position.

Fig. 1-1: I/O Output Timing Control Function

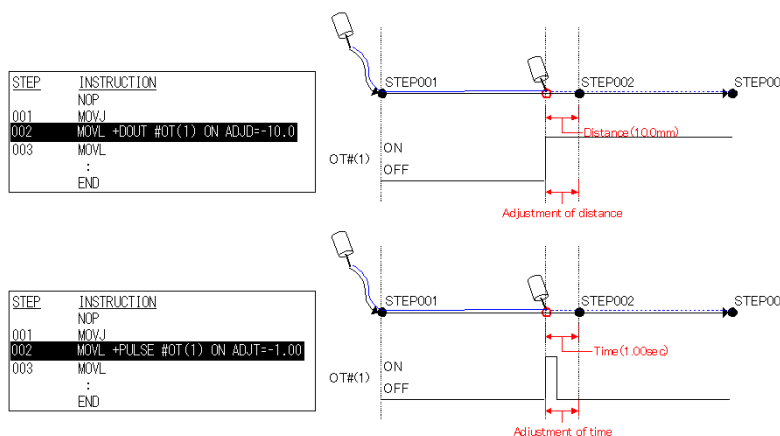

In case of the signal output is specified as distance, and the manipulator does not reach to the signal output position, such as the movement of the inward turning operation, the signal will be outputted when the manipulator comes to closest approach.

**NOTE**

STEP	INSTRUCTION
001	NOP
002	MOVJ +DOUT #OT(1) ON ADJD=0.0
003	MOVL : END

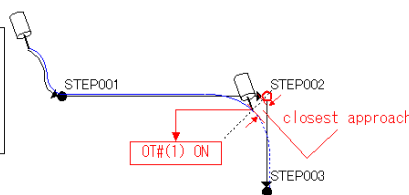



## 2 Setup of I/O Output Timing Control Function

### 2.1 Instruction of I/O Output Timing Control Function

#### 2.1.1 Configuration of Synchronized Signal Output Instruction at Move Instruction

On the I/O output timing control function, as shown in *Table 2-1 Configuration of Synchronized Output Signal*. The synchronized signal output instruction (+DOUT/+PULSE) added to the move instruction will output the general output signal. The configuration of instruction is shown as follows.

Fig. 2-1: Configuration of Synchronized Output Signal

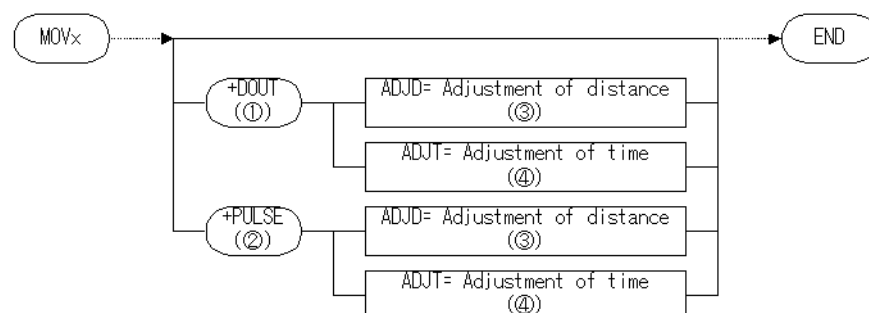

- ① +DOUT  
Synchronized signal output instruction
- ② +PULSE  
Synchronized pulse output instruction
- ③ ADJD=  
Adjustment distance tag (setting data range: -3276.8 to 0.0[mm])
- ④ ADJT=  
Adjustment time tag (setting data range: -3276.8 to 0.0[mm])

#### NOTE

The synchronized signal output instruction (+DOUT/+PULSE) can be added four move instructions, as follows  
• MOVJ/MOVL/MOVC/IMOV

#### NOTE

The I/O output timing control function can only adjust timing of the signal output to the previous direction (-direction) against the teaching position. For the backward direction (+direction) from the teaching position, operate the signal output to adjust to the previous direction against the teaching position of the next move instruction.

## 2.1.2 Configuration of +DOUT Instruction

+DOUT instruction which is added to the move instruction performs adjustment to the output timing of the general output signal.

The additional item of the +DOUT instruction is shown as follows.

Fig. 2-2: Configuration of +DOUT

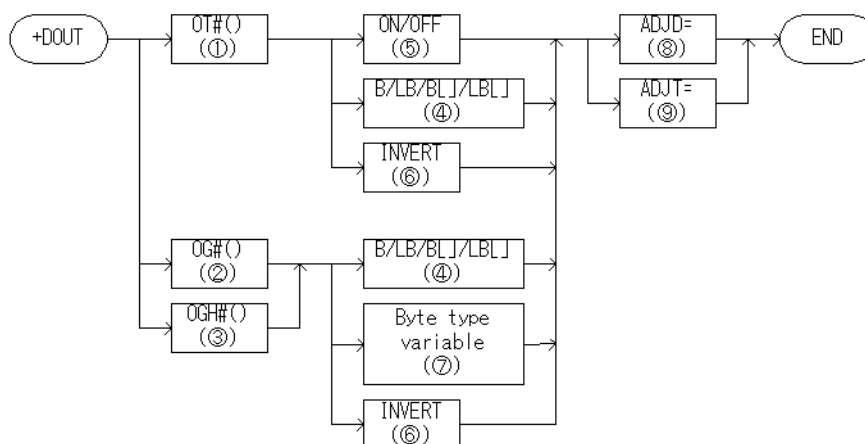

Choose of the tags from the following table

No	Tag	Explanation	Note
1	OT# (Output No.)	Specifies the output number signal.	No:1 to 4096 Variable B/I/D/LB/LI/LD can be used.
2	OG# (Output group No.)	Specifies the output number group signal (1group 8 points).	No:1 to 512 Variable B/I/D/LB/LI/LD can be used.
3	OGH# (Output group No.)	Specifies the output number group signal (1group 4 points).	No:1 to 1024 Variable B/I/D/LB/LI/LD can be used.

### Output signal

Output signal OT#(x) is 1 point, OGH#(x) is 1 group 4 points,  
and OG#(x) is 1 group 8 points.



OT#(8)	OT#(7)	OT#(6)	OT#(5)	OT#(4)	OT#(3)	OT#(2)	OT#(1)
OGH#(2)				OGH#(1)			
OG#(1)							

No	Tag	Explanation	Note
4	B Variable number/ LB Variable number / B [Array number]/ LB [Array number]	The least significant bit of the specified byte type variable specifies ON/OFF of the output signal.	Least significant bit: 0: OFF 1: ON
5	ON/OFF	Specifies ON/OFF of the output signal.	
6	INVERT	Refers the current signal status to output OFF when the status is ON, and output ON when the status is OFF.	

No	Tag	Explanation	Note
7	Byte type constant	When the constant byte type is expressed in bit form, the corresponding ON/OFF output signal is specified. Specifies ON/OFF of the output signal by bit value.	
8	ADJD	Based on the teaching position for the move instruction, specifies the distance of the previous direction (-direction) against the teaching position. In case of specified [ADJD=0.0], the signal will be outputted when the manipulator passed the teaching position or comes to the closest approach.	No:-3276.8 to 0.0 [mm] Variable B/I/D/LB/LI/LD can be used.



If specified adjustment distance from [ADJD=] is longer than the movement distance of the target step, the signal will be outputted at the moment of the cursor moves to the move instruction. Unable to adjust the signal output timing across the steps.

No	Tag	Explanation	Note
9	ADJT	Based on the teaching position for the move instruction, specifies the time of the previous direction (-direction) against the teaching position.	No: -327.68 to 0.00 [sec] Variable B/I/D/LB/LI/LD can be used.



If specified adjustment time from [ADJT=] is longer than the movement time of the target step, the signal will be outputted at the moment of the cursor moves to the move instruction. Unable to adjust the signal output timing across the steps.

**2.1.3 Registration of +DOUT Instruction**

Perform the registration of instructions while the cursor is in the address area of the job content display on the teach mode.

1. Select {JOB} under the main menu.
2. Select {JOB CONTENT}.
3. Move the cursor to desired move instruction of the teaching position to register the +DOUT instruction.



4. Press [SELECT].
  - Move instruction appears in the input buffer line.



## 5. Changing additional item of the +DOUT instructions

- Move the cursor to the input buffer line, and then press the [SELECT] key to appear the detail edit display of the move instruction.

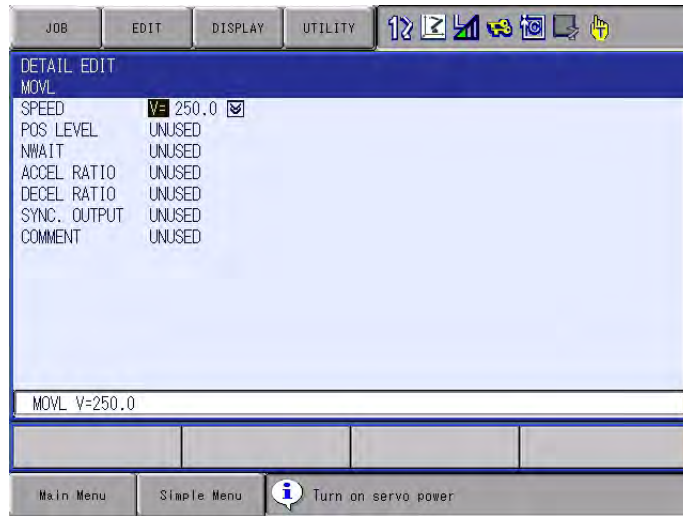

- Move the cursor to the [UNUSED] of the [SYNC. OUTPUT], and press [SELECT] key.

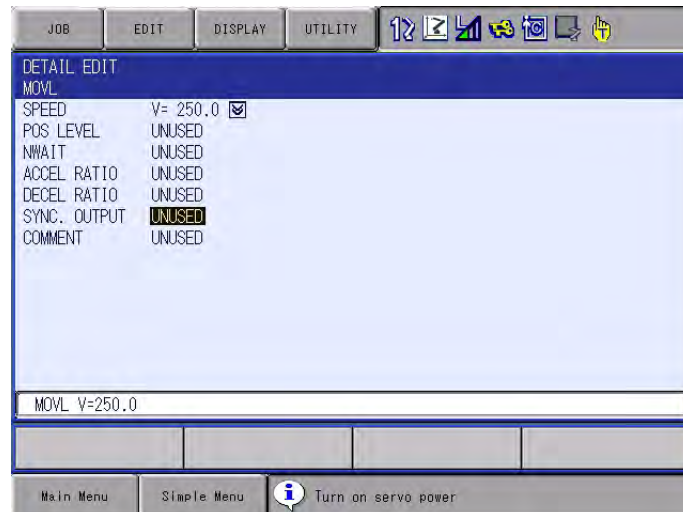

- When the selection dialog appears, select the [+DOUT] to display the detail edit display of the [+DOUT].



- To change from [OUTPUT TO] to [OG#()] or [OGH#()], move the cursor to [OT#()] of [OUTPUT TO], and press [SELECT] key. The selection dialog will appear, then select [OG#()] or [OGH#()].

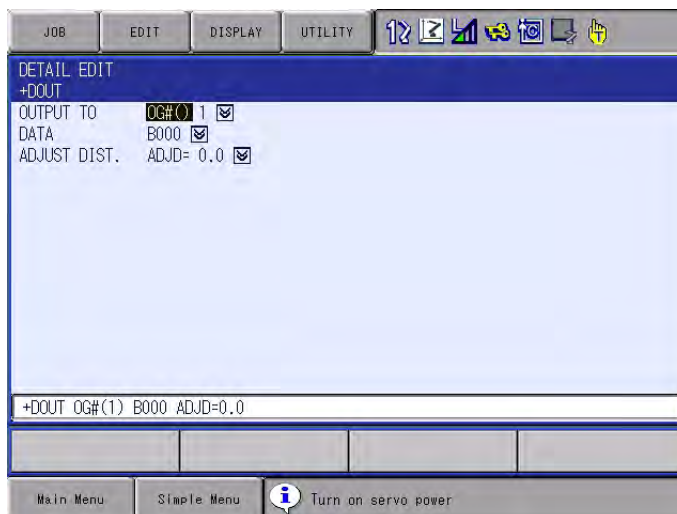

- To add [ADJUST TIME], move the cursor to [ADJ=], and press [SELECT] key. The selection dialog will appear, then select [ADJT=].

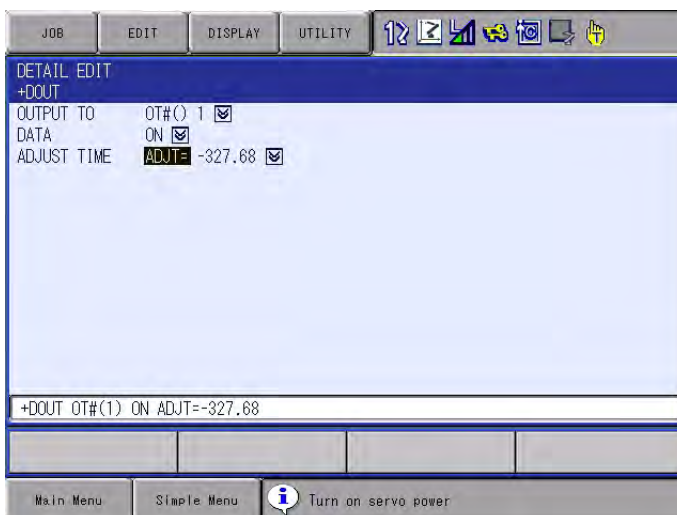

- After adding or changing of additional items, and press [ENTER] key. The detail edit display of [+DOUT] will disappear, and the detail edit display of the move instruction will appear again.



- Press [ENTER] key, and the detail edit display of the move instruction will disappear. The job content display will appear.

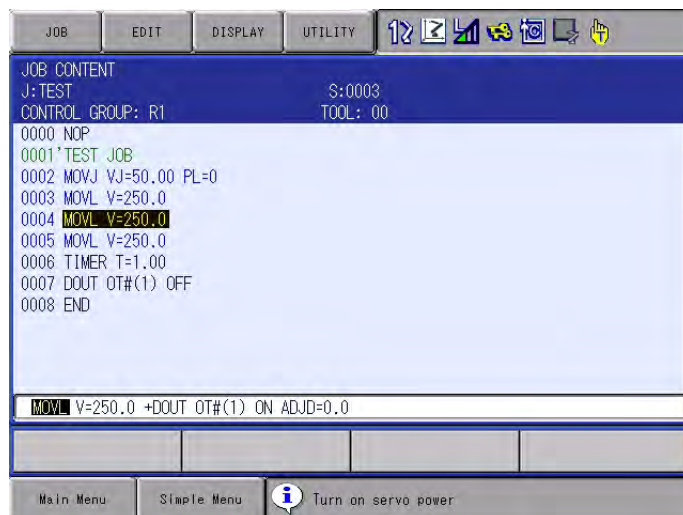

#### 6. Press [ENTER] key.

- The instruction in the input buffer line will be registered.

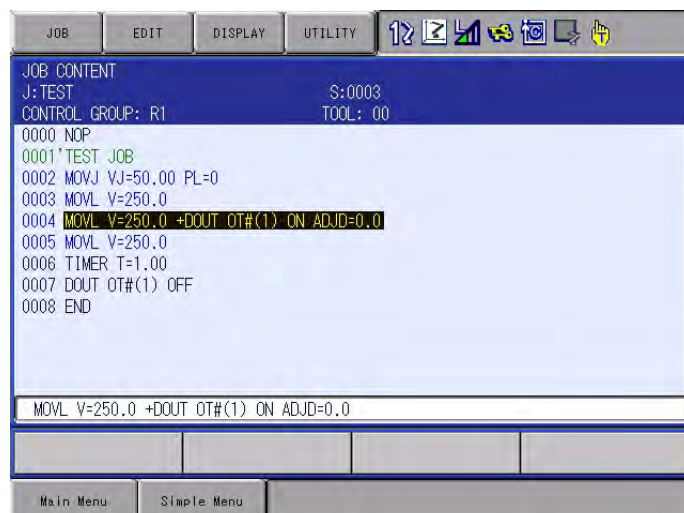



## 2.1.4 Configuration of +PULSE Instruction

+PULSE instruction which is added to the move instruction performs adjustment to the pulse output timing of the general output signal.

The additional item of the +PULSE instruction is shown as follows.

Fig. 2-3: The Configuration of +PULSE Instruction

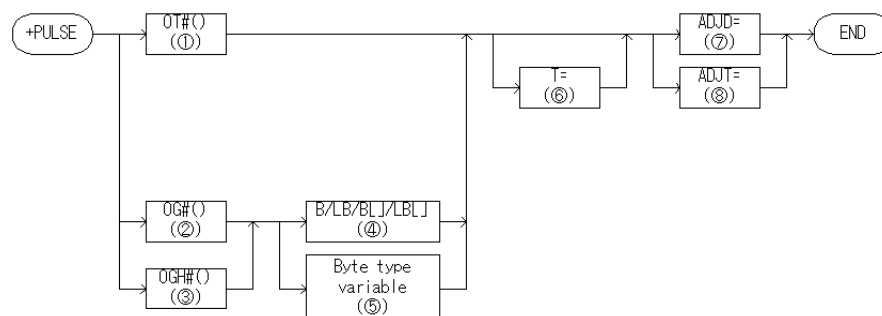

Choose one of the tags from the following table

No	Tag	Explanation	Note
1	OT# (Output No.)	Specifies the number of the signal to which the pulse signal is output.	No.: 1 to 4096 Variable B/I/D/LB/LI/ LD can be used.
2	OG# (Output group No.)	Specifies the group number of the signal (1 group 8 points) to which the pulse signal is output.	No.: 1 to 512 Variable B/I/D/LB/LI/ LD can be used.
3	OGH# (Output group No.)	Specifies the group number of the signal (1 group 4 points) to which the pulse signal is output.	No.: 1 to 1024 Variable B/I/D/LB/LI/ LD can be used.

### Output signal

Output signal OT#(x) is 1 point, OGH#(x) is 1 group 4 points, and OG#(x) is 1 group 8 points.



OT#(8)	OT#(7)	OT#(6)	OT#(5)	OT#(4)	OT#(3)	OT#(2)	OT#(1)
OGH#(2)				OGH#(1)			
OG#(1)							



No.	Tag	Explanation	Note
4	B Variable number/ LB Variable number/ B [Array Number] / LB [Array Number]	Specifies the number of the corresponding pulse output signal when the contents of the specified byte type variable is expressed in bits.	Bit: 0: OFF 1: ON
5	Byte type constant	Specifies the number of the corresponding pulse output signal when the specified byte type constant is expressed in bits.	
6	T=Time	Specifies the time during which the pulse signal is output. The pulse signal is output during the specified time T.	Units: seconds Variable I/LI/I[]/LI[] can be used. (Units: 0.01 seconds) When the time is not specified, the pulse signal is output during 0.30 seconds.
7	ADJD	Based on the teaching position for the move instruction, specifies the distance of the previous direction (-direction) against the teaching position. In case of specified "ADJD=0.0", the signal will be outputted when the manipulator passed the teaching position or comes to the closest approach.	No:-3276.8 to 0.0 [mm] Variable B/I/D/LB/LI/LD can be used.



If specified adjustment distance from [ADJD=] is longer than the movement distance of target step, the signal will be outputted at the moment of the cursor moves to the move instruction. Unable to adjust the timing of signal output across the step.

No.	Tag	Explanation	Note
8	ADJT	Based on the teaching position for the move instruction, specifies the time of the previous direction (-direction) against the teaching position.	No: -327.68 to 0.00 [sec] Variable B/I/D/LB/LI/LD can be used.



If specified adjustment time from [ADJT=] is longer than the movement time of target step, the signal will be outputted at the moment of the cursor moves to the move instruction. Unable to adjust the timing of signal output across the step.

**2.1.5 Registration of +PULSE Instruction**

Perform the registration of instructions while the cursor is in the address area of the job content display on the teach mode.

1. Select {JOB} under the main menu.
2. Select {JOB CONTENT}.
3. Move the cursor to desired move instruction of the teaching position to register the +PULSE instruction.



4. Press [SELECT].
  - Move instruction appears in the input buffer line.



## 5. Changing additional item of the +PULSE instructions

- Move the cursor to the input buffer line, and then press the [SELECT] key to appear the detail edit display of the move instruction.

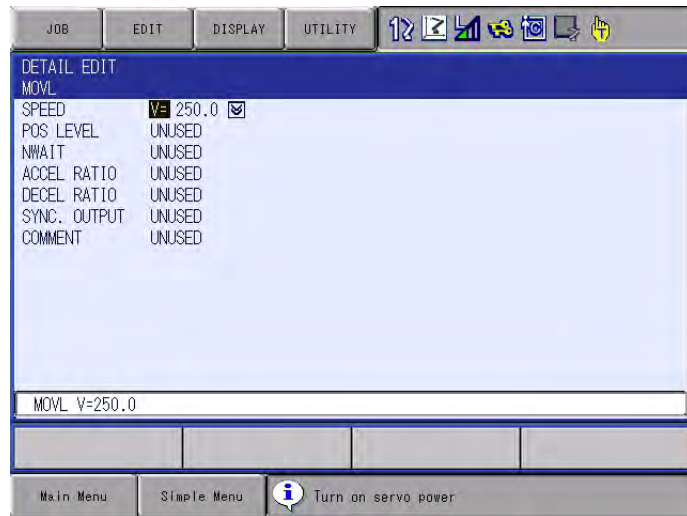

- Move the cursor to the [UNUSED] of [SYNC OUTPUT], and press [SELECT] key.

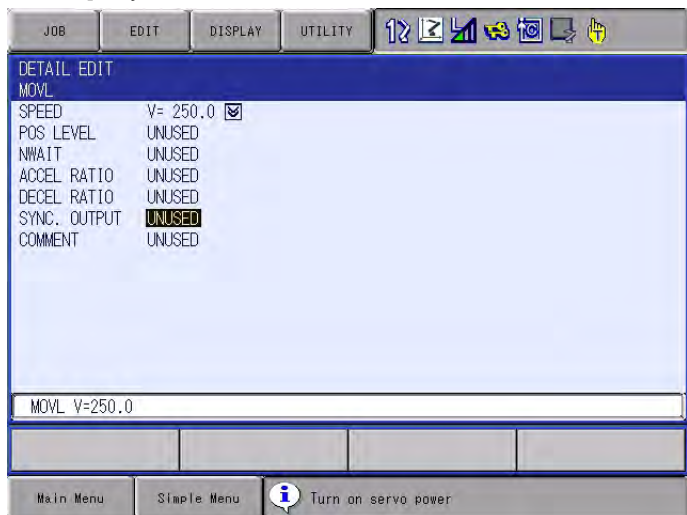

- When the selection dialog appears, select the [+PULSE] to display the detail edit display of the [+PULSE].

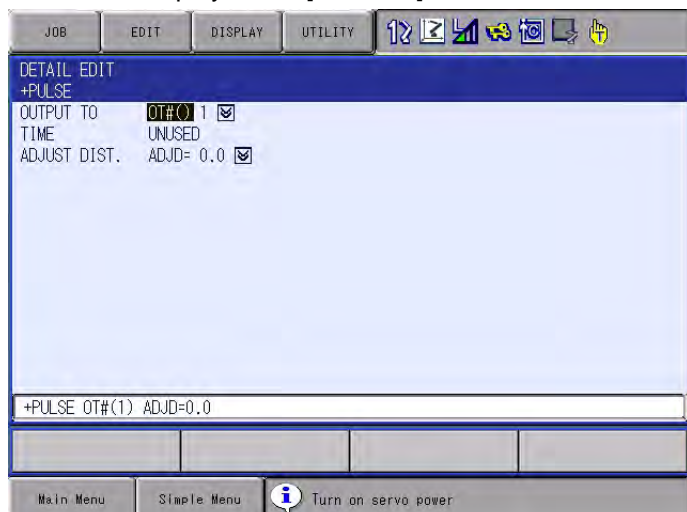

- To change from [OUTPUT TO] to [OG#()] or [OGH#()], move the cursor to [OT#()] of [OUTPUT TO], and press [SELECT] key. The selection dialog will appear, then select [OG#()] or [OGH#()].

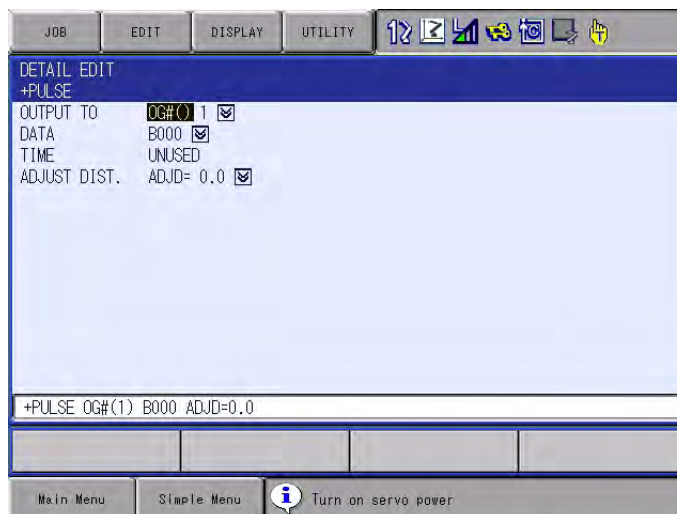

- To add [ADJUST TIME], move the cursor to [ADJ=], and press [SELECT] key. The selection dialog will appear, then select [ADJT=].

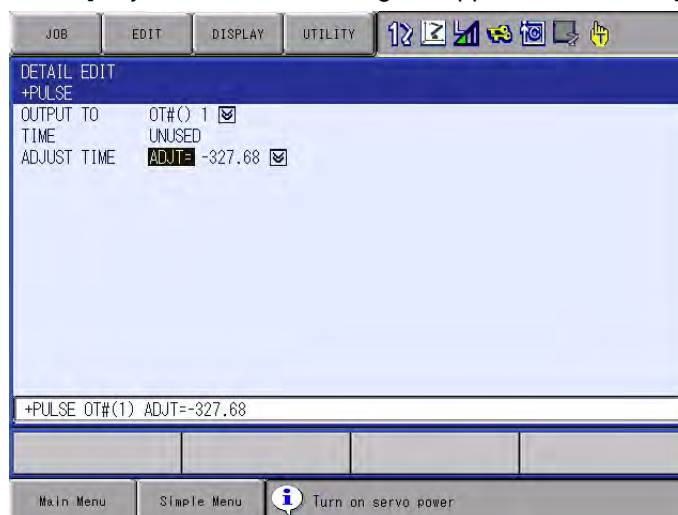

- After adding or changing of additional items, and press [ENTER] key. The detail edit display of [+PULSE] will disappear, and the detail edit display of the move instruction will appear again.

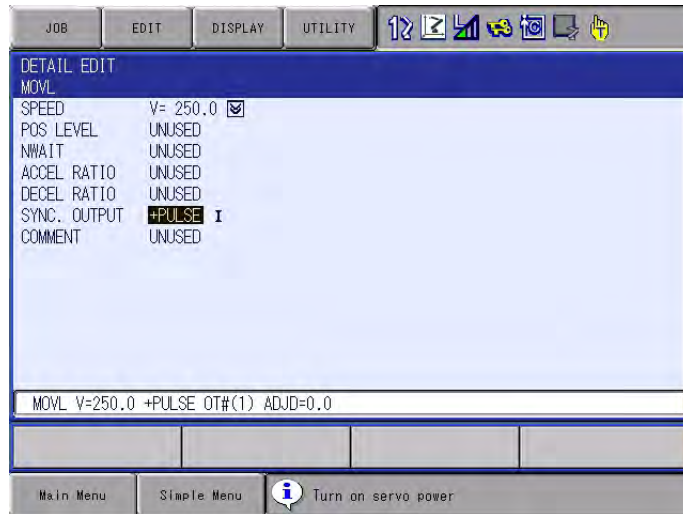

- Press [ENTER] key, and the detail edit display of the move instruction will disappear. The job content display will appear.

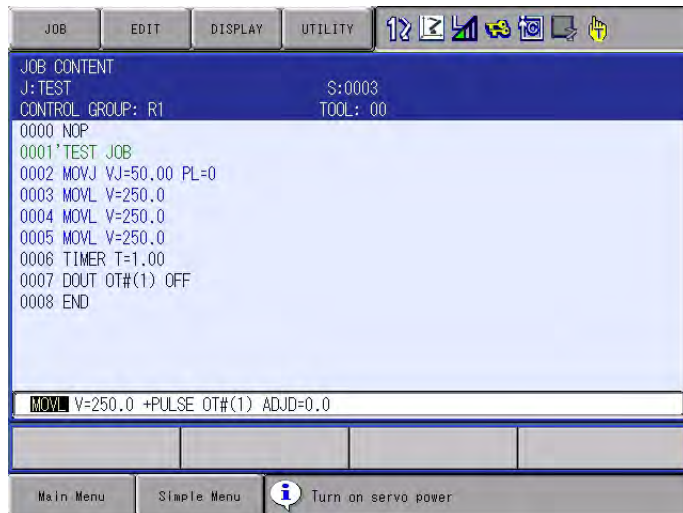

## 6. Press [ENTER] key.

- The instruction in the input buffer line will be registered.

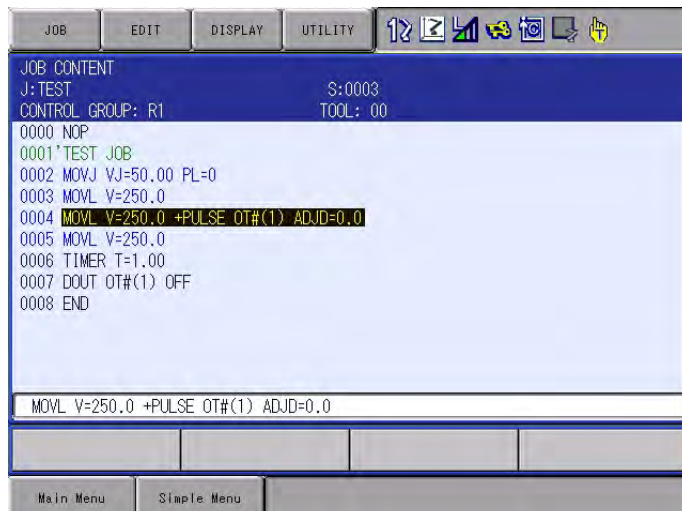

## 2.2 Device Response Delay Time Compensate Parameter

The response time of devices such as valve and cylinder which are controlled from the synchronized signal output instruction (+DOUT/+PULSE) is known from catalog.

In these cases, the synchronized signal output instruction (+DOUT/+PULSE) will be able to output the signal in advance by setting the response time from these devices on to the parameter. It is unnecessary to consider delayed time from the devices during the adjustment operation of the adjustment distance or adjustment time. Therefore, it will reduce the adjustment man-hours.

JOB KIND	No	Semantics	Unit	Initial value
S4C	321	Compensating time of device response delay	0.01sec	0

## 2.3 Signal Output Control Parameter During the FWD Operation

At the teaching mode, when the move instruction with synchronized signal output instruction (+DOUT/+PULSE) in the FWD operation will be executed, it is able to specify the general output signal as [output] or [no output]. The parameter shown as follows. The initial value is set on as [0: output]. To output signal during the FWD operation, change the setting to [1: output].

JOB KIND	No	Semantics	Unit	Initial value
S4C	247	+DOUT/+PULSE during the FWD operation Execute specification 0: No output 1: Output	-	0

## 2.4 Notes

- The synchronized signal output instruction (+DOUT/+PULSE) is added to the move instruction of the first line. Thus, the control group which is monitored at the setting position as [adjustment distance] or [adjustment time] will be a specified robot in the first line.
- When the synchronized signal output instruction will be added to the joint move instruction, adjustment distance at specified at ADJD will be the straight line between the previous step teaching position and the current step teaching position added with synchronized signal output instruction.
- When the move instruction with the synchronized signal output instruction will operate by the BACK operation, the signal would not be outputted.
- The signal may be outputted in the different position from the specified distance when the synchronized signal output instruction (+DOUT/+PULSE) is used at the distance (ADJD) in the operation locus which the controlled point of the manipulator will be operated reciprocating/helical motion in the short pitch.

## 2.5 The Examples of the I/O Output Timing Specifying Function

### ■ Specifying distance

In the case of setting [5] in to the parameter [S4C321: device response delay time]

STEP	INSTRUCTION
	NOP
001	MOVJ
002	MOVL +DOUT #OT(1) ON ADJD=-10.0
003	MOVL
	:
	END

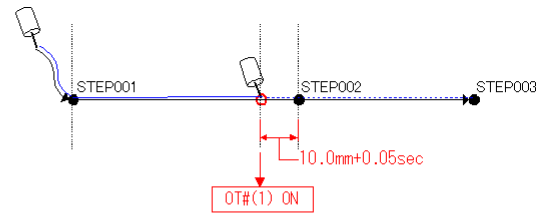

STEP	INSTRUCTION
	NOP
001	MOVJ
002	MOVL +DOUT #OT(1) ON ADJD=-1.0
003	MOVL
	:
	END

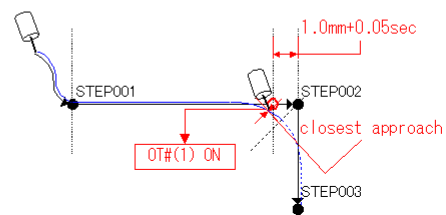

### ■ Specifying time

In the case of setting [5] in to the parameter [S4C321: device response delay time]

STEP	INSTRUCTION
	NOP
001	MOVJ
002	MOVL +DOUT #OT(1) ON ADJT=-1.00
003	MOVL
	:
	END

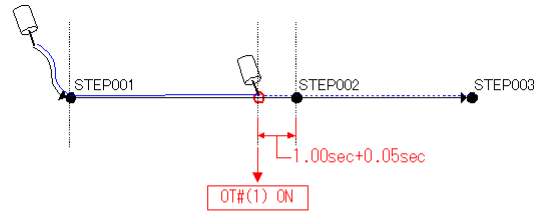

STEP	INSTRUCTION
	NOP
001	MOVJ
002	MOVL +DOUT #OT(1) ON ADJT=-1.00
003	MOVL
	:
	END

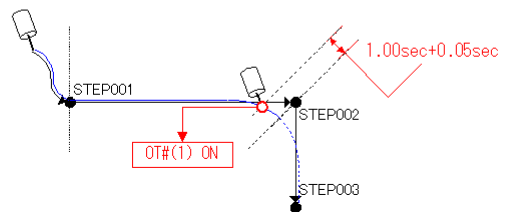



# DX200 OPTIONS INSTRUCTIONS

FOR I/O OUTPUT TIMING CONTROL FUNCTION

---

## HEAD OFFICE

2-1 Kurosakishiroishi, Yahatanishi-ku, Kitakyushu 806-0004, Japan  
Phone +81-93-645-7745 Fax +81-93-645-7746

YASKAWA America Inc. M Robotics Division  
100 Automation Way, Miamisburg, OH 45342, U.S.A.  
Phone +1-937-847-6200 Fax +1-937-847-6277

YASKAWA Nordic AB  
Box 504 Verkstadsgatan 2, PO Box 504 SE-385 25 Torsås, Sweden  
Phone +46-480-417-800 Fax +46-486-414-10

YASKAWA Europe GmbH Robotics Div.  
Yaskawastrasse 1, 85391 Allershausen, Germany  
Phone +49-8166-90-0 Fax +49-8166-90-103

YASKAWA Electric Korea Co., Ltd  
9F, KYOBO Securities Bldg., 26-4, Yeoido-Dong Yeounggeungpo-ku, Seoul, Korea  
Phone +82-2-784-7844 Fax +82-2-784-8495

YASKAWA Electric (Singapore) PTE Ltd.  
151 Lorong Chuan, #04-02A, New Tech Park, Singapore 556741  
Phone +65-6282-3003 Fax +65-6289-3003

YASKAWA Electric (Thailand) Co., Ltd.  
252/246, 4th Floor. Muang Thai-Phatra Office Tower II Rachadaphisek Road,  
Huaykwang Bangkok, 10320, Thailand  
Phone +66-2-693-2200 Fax +66-2-693-4200

YASKAWA Shougang Robot Co. Ltd.  
1015, Boxuenan Rd. Maluzhen, Jiading District, Shanghai, China  
Phone +86-21-5950-3521 Fax +86-20-3878-0651

YASKAWA ELECTRIC CHINA Co., Ltd.  
12F Carlton Building, No. 21-42 Huanghe Road, Shanghai 200003, China  
Phone +86-21-5385-2200 Fax +86-21-5385-3299

YASKAWA Robotics India Ltd.  
#426, Udyog Vihar, Phase- IV, Gurgaon, Haryana, India  
Phone +91-124-475-8500 Fax +91-124-475-8542

---

Specifications are subject to change without notice  
for ongoing product modifications and improvements.