

# DX200 OPTIONS INSTRUCTIONS

FOR TWIN DRIVE FUNCTION

---

Upon receipt of the product and prior to initial operation, read these instructions thoroughly, and retain for future reference.

---

## MOTOMAN INSTRUCTIONS

MOTOMAN--□□□ INSTRUCTIONS  
DX200 INSTRUCTIONS  
DX200 OPERATOR'S MANUAL  
DX200 MAINTENANCE MANUAL

The DX200 Operator's manual above corresponds to specific usage.  
Be sure to use the appropriate manual.

Part Number: 165308-1CD  
Revision: 0



## MANDATORY

- This manual explains the twin drive function of the DX200 system. Read this manual carefully and be sure to understand its contents before handling the DX200.
- General items related to safety are listed in Chapter 1: Safety of the DX200 Instructions. To ensure correct and safe operation, carefully read the DX200 Instructions before reading this manual.



## CAUTION

- Some drawings in this manual are shown with the protective covers or shields removed for clarity. Be sure all covers and shields are replaced before operating this product.
- The drawings and photos in this manual are representative examples and differences may exist between them and the delivered product.
- YASKAWA may modify this model without notice when necessary due to product improvements, modifications, or changes in specifications.
- If such modification is made, the manual number will also be revised.
- If your copy of the manual is damaged or lost, contact a YASKAWA representative to order a new copy. The representatives are listed on the back cover. Be sure to tell the representative the manual number listed on the front cover.
- YASKAWA is not responsible for incidents arising from unauthorized modification of its products. Unauthorized modification voids your product's warranty.

## Notes for Safe Operation

Read this manual carefully before installation, operation, maintenance, or inspection of the DX200.

In this manual, the Notes for Safe Operation are classified as "WARNING", "CAUTION", "MANDATORY", or "PROHIBITED".



### WARNING

Indicates a potentially hazardous situation which, if not avoided, could result in death or serious injury to personnel.



### CAUTION

Indicates a potentially hazardous situation which, if not avoided, could result in minor or moderate injury to personnel and damage to equipment. It may also be used to alert against unsafe practices.



### MANDATORY

Always be sure to follow explicitly the items listed under this heading.



### PROHIBITED

Must never be performed.

Even items described as "CAUTION" may result in a serious accident in some situations.

At any rate, be sure to follow these important items



To ensure safe and efficient operation at all times, be sure to follow all instructions, even if not designated as "CAUTION" and "WARNING".



## WARNING

- Before operating the manipulator, check that servo power is turned OFF pressing the emergency stop buttons on the front door of the DX200 and the programming pendant.  
When the servo power is turned OFF, the SERVO ON LED on the programming pendant is turned OFF.

Injury or damage to machinery may result if the emergency stop circuit cannot stop the manipulator during an emergency. The manipulator should not be used if the emergency stop buttons do not function.

*Figure 1: Emergency Stop Button*



- Once the emergency stop button is released, clear the cell of all items which could interfere with the operation of the manipulator.  
Then turn the servo power ON.

Injury may result from unintentional or unexpected manipulator motion.

*Figure 2: Release of Emergency Stop*

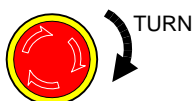

- Observe the following precautions when performing teaching operations within the P-point maximum envelope of the manipulator:
  - View the manipulator from the front whenever possible.
  - Always follow the predetermined operating procedure.
  - Keep in mind the emergency response measures against the manipulator's unexpected motion toward you.
  - Ensure that you have a safe place to retreat in case of emergency.

Improper or unintended manipulator operation may result in injury.

- Confirm that no person is present in the P-point maximum envelope of the manipulator and that you are in a safe location before:
  - Turning ON the power for the DX200.
  - Moving the manipulator with the programming pendant.
  - Running the system in the check mode.
  - Performing automatic operations.
- Injury may result if anyone enters the P-point maximum envelope of the manipulator during operation. Always press an emergency stop button immediately if there is a problem. The emergency stop buttons are located on the right of front door of the DX200 and the programming pendant.



## CAUTION

- Perform the following inspection procedures prior to conducting manipulator teaching. If problems are found, repair them immediately, and be sure that all other necessary processing has been performed.
  - Check for problems in manipulator movement.
  - Check for damage to insulation and sheathing of external wires.
- Always return the programming pendant to the hook on the cabinet of the DX200 after use.

The programming pendant can be damaged if it is left in the manipulator's work area, on the floor, or near fixtures.

- Read and understand the Explanation of Warning Labels in the DX200 Instructions before operating the manipulator:

## Definition of Terms Used Often in This Manual

The MOTOMAN is the YASKAWA industrial robot product.

The MOTOMAN usually consists of the manipulator, the controller, the programming pendant, and supply cables.

In this manual, the equipment is designated as follows:

Equipment	Manual Designation
DX200 controller	DX200
DX200 programming pendant	Programming pendant
Cable between the manipulator and the controller	Manipulator cable

Descriptions of the programming pendant keys, buttons, and displays are shown as follows:

Equipment		Manual Designation
Programming Pendant	Character Keys /Symbol Keys	The keys which have characters or its symbol printed on them are denoted with [ ]. ex. [ENTER]
	Axis Keys /Numeric Keys	[Axis Key] and [Numeric Key] are generic names for the keys for axis operation and number input.
	Keys pressed simultaneously	When two keys are to be pressed simultaneously, the keys are shown with a "+" sign between them, ex. [SHIFT]+[COORD]
	Displays	The menu displayed in the programming pendant is denoted with { }. ex. {JOB}

## Description of the Operation Procedure

In the explanation of the operation procedure, the expression "Select ●●●" means that the cursor is moved to the object item and the SELECT key is pressed, or that the item is directly selected by touching the screen.

## Registered Trademark

In this manual, names of companies, corporations, or products are trademarks, registered trademarks, or brand names for each company or corporation. The indications of (R) and <sup>TM</sup> are omitted.

## Table of Contents

---

1	Outline .....	1-1
2	Applicable Types.....	2-1
3	Operation .....	3-1
3.1	Axis Operation .....	3-1
3.1.1	Twin Motion Mode .....	3-2
3.1.2	Single Motion Mode.....	3-3
3.1.3	Precautions .....	3-3
4	Setting Parameters .....	4-1
5	Status Display .....	5-1
6	Precautions.....	6-1
6.1	Precautions when selecting Motor.....	6-1
6.2	Precautions when Setting External Axes.....	6-1
6.2.1	Setting Mechanical Specifications .....	6-1
6.2.2	Setting Motor Specifications .....	6-1
6.2.3	Setting the Rotating Direction.....	6-1
6.3	Setting the Home Position .....	6-2
6.4	Precautions upon Application with Coordinated Motion .....	6-2
6.4.1	Coordinated Motion with TWIN-2 .....	6-2

## 1 Outline

When configuring the external axes (base or station axes) in the DX200 and using a single motor to control an axis with a heavy load applied during an operation, a large-capacity motor with sufficient capacity and torque is required.

In this case, the external axis becomes very large and requires a wide space for equipment installation.

A system, where an external axis with a heavy load is operated by two motors may be built to provide the necessary motor capacity and torque.

In such a system, the two motors must be operated at the same time, or the system and external axes may be damaged.

Use the twin drive function to operate the motor on the slave axis side at the same time as the external master axis during teaching.

This function economizes on system space and obtains sufficient motor power.

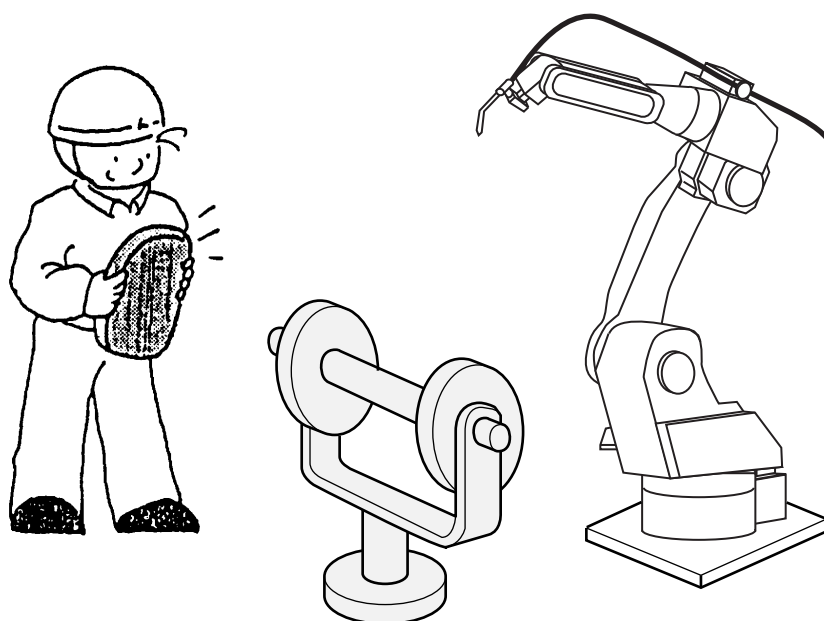



## 2 Applicable Types

The twin drive function is valid only for the station axes that have been configured for the twin drive.

The following table lists the configurations and the three types of stations where the twin drive can be used.

Station type	Configuration			Remarks
	Number of station axes	Master axis	Slave axis	
TWIN -3A (TDT3A)	3 axes	Second axis	Third axis	See Fig. 2-1(a)
TWIN -3B (TDT3B)	3 axes	First axis	Third axis	See Fig. 2-2(a)
TWIN -2 (TDT2)	2 axes	First axis	Second axis	See Fig. 2-3(a)

The above three station types can be selected when setting the station axis for the system configuration.

Fig. 2-1(a): TWIN-3A

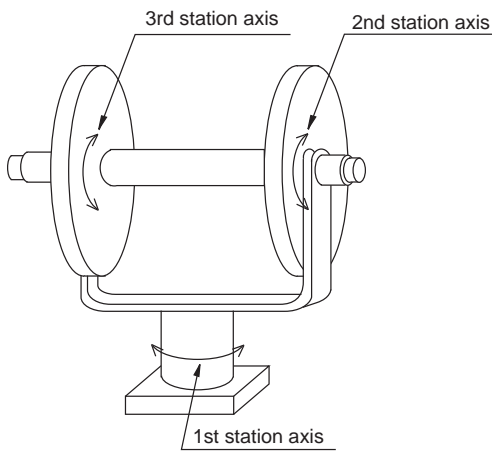

Fig. 2-2(a): TWIN-3B

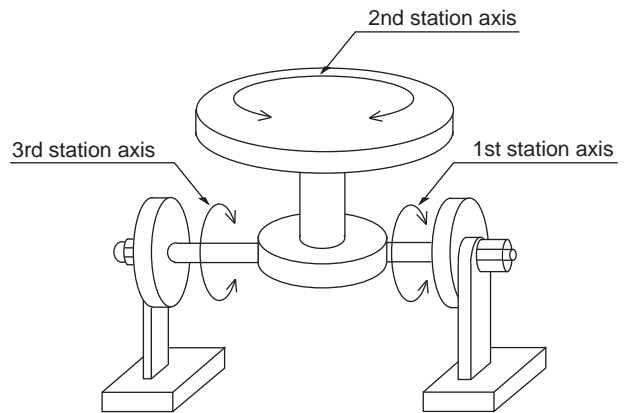
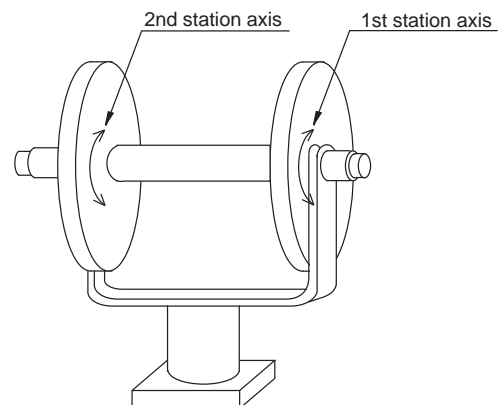

Fig. 2-3(a): TWIN-2



## 3 Operation

When the external axis with the twin drive is selected for the axis operation, the twin-driven axes (master axis and slave axis) can be operated at the same time by a single instruction.

External axis operation and teaching can be easily performed when teaching.

During playback, the axes move according to the taught job data.

### 3.1 Axis Operation

When the external axis with the twin drive is selected for the axis operation, the following motion is performed.

For the external axis with the twin drive, press the master axis key, and the slave axis and the master axis move at the same time.

However, the external input signal specified by the parameters restricts the axis as outlined in the following table.

External input signal	ON	Single motion mode
	OFF	Twin motion mode

The following describes each mode.

### 3.1.1 Twin Motion Mode

When using the twin drive, the axes can move in twin motion mode.

When the specified external input status is OFF, the axes move in the twin (concurrent) motion mode.

[Example] For TWIN-2

Press the 1st axis key to move the 2nd axis and the 1st axis at the same time.

In this case, no axis moves when the 2nd axis key is pressed.

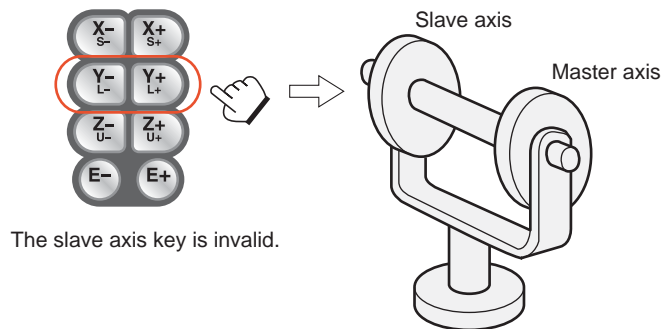
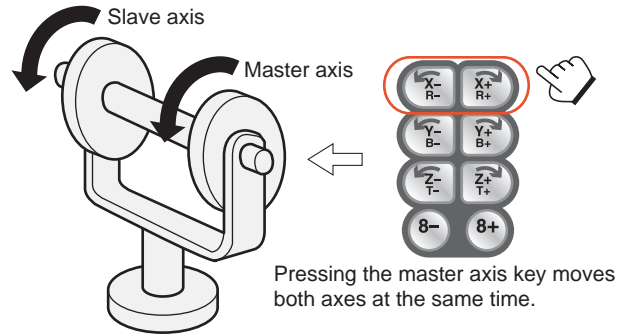

**3.1.2 Single Motion Mode**

In this mode, the master axis and the slave axis move individually.

When the specified external input status is ON, each axis moves in a single motion.

[Example] For TWIN-2

Press the 1st axis key or the 2nd axis key to move the corresponding axis only.

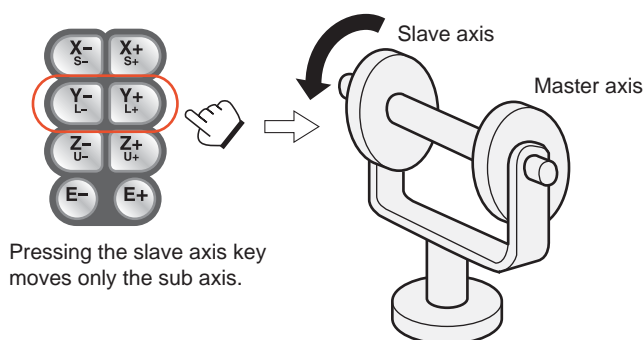
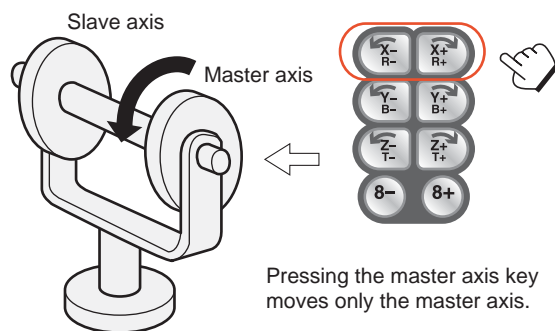
**3.1.3 Precautions**

Select either the twin motion mode or the single motion mode by external input before starting the axis operation.

The motion mode does not change when the external input status is changed while an axis key is pressed.

The motion mode is determined according to the external input status that exists when the axis key is pressed, not after.

## 4 Setting Parameters

In the twin drive, the status of external general-purpose input signal determines the mode as the twin motion or single motion.

The following parameters specify the general-purpose input numbers.

Parameter	Contents	
S4C262	General-purpose input number specification in the twin drive	Station 1
S4C263		Station 2
S4C264		Station 3
S4C265		Station 4
S4C266		Station 5
S4C267		Station 6
:		:
S4C285		Station 24

When general-purpose input numbers are not set to the above parameters (when "0" is set) for the station axes with twin drive function, the twin motion is the default mode.

## 5 Status Display

The application status of the twin drive function can be confirmed.

1. Select {ROBOT} from the menu.
2. Select {TWIN DRIVE}.
  - The twin drive display appears.



**MASTER** : The number of the master axis appears when the twin drive function is used.

**SUB** : The number of the slave axis appears when the twin drive function is used.

**INPUT NO.** : The general-purpose input number set for the parameter appears.

When there is not set general-purpose input number, "[ - - ]" appears.

**MODE** : The external input signal status appears.

"TWIN" : The specified general-purpose input is OFF.  
The twin (concurrent) motion is possible.

"SINGLE" : The specified general-purpose input is ON.  
The single motion is possible.

## **6 Precautions**

Observe the following precautions when using the twin drive.

### **6.1 Precautions when selecting Motor**

When using the twin drive, both twin-driven axes have to move in the same way and the same level for both axis operation and playback.

Use the same motors for the twin-driven axes.

### **6.2 Precautions when Setting External Axes**

To use the twin drive function, the external axes must be in maintenance mode.

Note the following precautions when setting the external axes.

For operation methods in the maintenance mode, refer to “DX200 Instruction Manual” (MANUAL NO.: 165557-1CD).

#### **6.2.1 Setting Mechanical Specifications**

When setting the station axis, enter the following data for the mechanical specifications.

- MOTION RANGE (+)
- MOTION RANGE (-)
- REDUCTION RATIO (NUMER)
- REDUCTION RATIO (DENOM)

When using the twin drive, both twin-driven axes have to move in the same way and the same level for both axis operation and playback. Set the same condition data for both axes.

#### **6.2.2 Setting Motor Specifications**

When setting a station axis, enter the following data for the motor specifications.

- ROTATION DIRECTION (NORMAL/REVERSE)
- MAX. RPM
- ACCELERATION TIME
- INERTIA RATIO

When using the twin drive function, both twin-driven axes have to move in the same way and the same level for both axis operation and playback. Set the same condition data for “MAX. RPM”, “ACCELERATION TIME”, and “INERTIA RATIO” of both axes.

#### **6.2.3 Setting the Rotating Direction**

When using the twin drive, specify the same motor rotating direction for both twin-driven axes. Specifying a different direction for each axis may damage a jig and break down the system.

Before using the twin drive, confirm the rotating direction of the twin-driven axes to set the correct rotating direction.

### **6.3 Setting the Home Position**

Operate the two station axes configured for the twin drive at the same time and teach the home position so that the two axes have the same “0” position.

Because the two axes have the same “0” pulse position, axis operation and playback can be performed with the same pulse value.

### **6.4 Precautions upon Application with Coordinated Motion**

The station coordinated function can be used as an option. The following restrictions apply for the station axes with the twin drive.

#### **6.4.1 Coordinated Motion with TWIN-2**

When the robot moves in a coordinated motion using TWIN-2, the coordinated motion is applied to the 1st station axis. The 2nd station axis and the 1st station axis move in twin drive.

Calibrate the 1st station axis only.

The coordinated motion is not valid for the 2nd station axis.



# DX200 OPTIONS INSTRUCTIONS

FOR TWIN DRIVE FUNCTION

---

## HEAD OFFICE

2-1 Kurosakishiroishi, Yahatanishi-ku, Kitakyushu 806-0004, Japan  
Phone +81-93-645-7745 Fax +81-93-645-7746

YASKAWA America Inc. M Robotics Division  
100 Automation Way, Miamisburg, OH 45342, U.S.A.  
Phone +1-937-847-6200 Fax +1-937-847-6277

YASKAWA Nordic AB  
Box 504 Verkstadsgatan 2, PO Box 504 SE-385 25 Torsås, Sweden  
Phone +46-480-417-800 Fax +46-486-414-10

YASKAWA Europe GmbH Robotics Div.  
Yaskawastrasse 1, 85391 Allershausen, Germany  
Phone +49-8166-90-0 Fax +49-8166-90-103

YASKAWA Electric Korea Co., Ltd  
9F, KYOBO Securities Bldg., 26-4, Yeoido-Dong Yeounggeungpo-ku, Seoul, Korea  
Phone +82-2-784-7844 Fax +82-2-784-8495

YASKAWA Electric (Singapore) PTE Ltd.  
151 Lorong Chuan, #04-02A, New Tech Park, Singapore 556741  
Phone +65-6282-3003 Fax +65-6289-3003

YASKAWA Electric (Thailand) Co., Ltd.  
252/246, 4th Floor. Muang Thai-Phatra Office Tower II Rachadaphisek Road,  
Huaykwang Bangkok, 10320, Thailand  
Phone +66-2-693-2200 Fax +66-2-693-4200

YASKAWA Shougang Robot Co. Ltd.  
1015, Boxuenan Rd. Maluzhen, Jiading District, Shanghai, China  
Phone +86-21-5950-3521 Fax +86-20-3878-0651

YASKAWA ELECTRIC CHINA Co., Ltd.  
12F Carlton Building, No. 21-42 Huanghe Road, Shanghai 200003, China  
Phone +86-21-5385-2200 Fax +86-21-5385-3299

YASKAWA Robotics India Ltd.  
#426, Udyog Vihar, Phase- IV, Gurgaon, Haryana, India  
Phone +91-124-475-8500 Fax +91-124-475-8542

---

Specifications are subject to change without notice  
for ongoing product modifications and improvements.