

NX100

Concurrent I/O

Upon receipt of the product and prior to initial operation, read these instructions thoroughly, and retain for future reference.

MOTOMAN INSTRUCTIONS

MOTOMAN-□□□ INSTRUCTIONS

NX100 INSTRUCTIONS

NX100 OPERATOR'S MANUAL

NX100 MAINTENANCE MANUAL

The NX100 operator's manual above corresponds to specific usage.

Be sure to use the appropriate manual.

Part Number: 149230-1CD

Revision: 4

Copyright © 2016, Yaskawa America, Inc.

Terms of Use and Copyright Notice

All rights reserved. This manual is freely available as a service to Yaskawa customers to assist in the operation of Motoman robots, related equipment and software. This manual is copyrighted property of Yaskawa and may not be sold or redistributed in any way. You are welcome to copy this document to your computer or mobile device for easy access but you may not copy the PDF files to another website, blog, cloud storage site or any other means of storing or distributing online content.

Printed in the United States of America

First Printing, 2016

Yaskawa America, Inc.
Motoman Robotics Division
100 Automation Way
Miamisburg, OH 45342
Phone: 937-847-6200

www.motoman.com



MANDATORY

- This manual explains the various components of the NX100 system and general operations. Read this manual carefully and be sure to understand its contents before handling the NX100.
- General items related to safety are listed in Section 1: Safety of the NX100 Instructions. To ensure correct and safe operation, carefully read the NX100 Instructions before reading this manual.



CAUTION

- Some drawings in this manual are shown with the protective covers or shields removed for clarity. Be sure all covers and shields are replaced before operating this product.
- The drawings and photos in this manual are representative examples and differences may exist between them and the delivered product.
- YASKAWA may modify this model without notice when necessary due to product improvements, modifications, or changes in specifications. If such modification is made, the manual number will also be revised.
- If your copy of the manual is damaged or lost, contact a YASKAWA representative to order a new copy. The representatives are listed on the back cover. Be sure to tell the representative the manual number listed on the front cover.
- YASKAWA is not responsible for incidents arising from unauthorized modification of its products. Unauthorized modification voids your product's warranty.

We suggest that you obtain and review a copy of the ANSI/RIA National Safety Standard for Industrial Robots and Robot Systems (ANSI/RIA R15.06-2012). You can obtain this document from the Robotic Industries Association (RIA) at the following address:

Robotic Industries Association
900 Victors Way
P.O. Box 3724
Ann Arbor, Michigan 48106
TEL: (734) 994-6088
FAX: (734) 994-3338
www.roboticsonline.com

Ultimately, well-trained personnel are the best safeguard against accidents and damage that can result from improper operation of the equipment. The customer is responsible for providing adequately trained personnel to operate, program, and maintain the equipment. **NEVER ALLOW UNTRAINED PERSONNEL TO OPERATE, PROGRAM, OR REPAIR THE EQUIPMENT!**

We recommend approved Yaskawa training courses for all personnel involved with the operation, programming, or repair of the equipment.

This equipment has been tested and found to comply with the limits for a Class A digital device, pursuant to part 15 of the FCC rules. These limits are designed to provide reasonable protection against harmful interference when the equipment is operated in a commercial environment. This equipment generates, uses, and can radiate radio frequency energy and, if not installed and used in accordance with the instruction manual, may cause harmful interference to radio communications.

NOTES FOR SAFE OPERATION

Read this manual carefully before installation, operation, maintenance, or inspection of the NX100. In this manual, the Notes for Safe Operation are classified as "WARNING", "CAUTION", "MANDATORY", or "PROHIBITED".



WARNING

Indicates a potentially hazardous situation which, if not avoided, could result in death or serious injury to personnel.



CAUTION

Indicates a potentially hazardous situation which, if not avoided, could result in minor or moderate injury to personnel and damage to equipment. It may also be used to alert against unsafe practices.



MANDATORY

Always be sure to follow explicitly the items listed under this heading.



PROHIBITED

Must never be performed.

Even items described as "CAUTION" may result in a serious accident in some situations. At any rate, be sure to follow these important items.



To ensure safe and efficient operation at all times, be sure to follow all instructions, even if not designated as "CAUTION" and "WARNING".

NOTES FOR SAFE OPERATION



WARNING

- Before operating the manipulator, check that servo power is turned off when the emergency stop button on the front door of the NX100 and the programming pendant is pressed. When the servo power is turned OFF, the SERVO ON READY lamp on the SERVO ON LED on the programming pendant is turned OFF.

Injury or damage to machinery may result if the emergency stop circuit cannot stop the manipulator during an emergency. The manipulator should not be used if the emergency stop buttons do not function.



Emergency Stop Button

- Once the emergency stop button is released, clear the cell of all items which could interfere with the operation of the manipulator. Then turn OFF the servo power.

Injury may result from unintentional or unexpected manipulator motion.

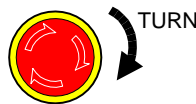

Release of Emergency Stop

- Observe the following precautions when performing teaching operations within the working envelope of the manipulator:
 - View the manipulator from the front whenever possible.
 - Always follow the predetermined operating procedure.
 - Ensure that you have a safe place to retreat in case of emergency.

Improper or unintended manipulator operation may result in injury.

- Confirm that no persons are present in the manipulator's work envelope and that you are in a safe location before:
 - Turning ON the NX100 power.
 - Moving the manipulator with the programming pendant.
 - Running check operations.
 - Performing automatic operations.

Injury may result if anyone enters the working envelope of the manipulator during operation. Always press an emergency stop button immediately if there are problems. The emergency stop button is located on the right of the front door of the NX100 and the programming pendant.



CAUTION

- Perform the following inspection procedures prior to conducting manipulator teaching. If problems are found, repair them immediately, and be sure that all other necessary processing has been performed.
 - Check for problems in manipulator movement.
 - Check for damage to insulation and sheathing of external wires.

- Always return the programming pendant to the hook on the NX100 cabinet after use.

The programming pendant can be damaged if it is left in the manipulator's work area, on the floor, or near fixtures.

- Read and understand the Explanation of Warning Labels in the NX100 Instructions before operating the manipulator.

Definition of Terms Used Often in This Manual

The MOTOMAN is the YASKAWA industrial robot product.

The MOTOMAN usually consists of the manipulator, the controller, the programming pendant, and the manipulator cables.

In this manual, the equipment is designated as follows:.

Equipment	Manual Designation
NX100 Controller	NX100
NX100 Programming Pendant	Programming Pendant
Cable between the manipulator and the controller	Manipulator Cable

Description of the Operation Procedure

Descriptions of the programming pendant keys, buttons, and displays are shown as follows:

Equipment		Manual Designation
Programming Pendant	Character Keys	The keys which have characters printed on them are denoted with []. ex. [ENTER]
	Symbol Keys	The keys which have a symbol printed on them are not denoted with [] but depicted with a small picture. ex. page key  The cursor key is an exception, and a picture is not shown.
	Axis Keys Number Keys	“Axis Keys” and “Number Keys” are generic names for the keys for axis operation and number input.
	Keys pressed simultaneously	When two keys are to be pressed simultaneously, the keys are shown with a “+” sign between them, ex. [SHIFT]+[COORD]
	Displays	The menu displayed in the programming pendant is denoted with { }. ex. {JOB}

Description of the Operation Procedure

In the explanation of the operation procedure, the expression “Select •••” means that the cursor is moved to the object item and the SELECT key is pressed, or that the item is directly selected by touching the screen.

Registered Trademark

In this manual, names of companies, corporations, or products are trademarks, registered trademarks, or brand names for each company or corporation. The indications of (R) and TM are omitted.

Customer Support Information

If you need assistance with any aspect of your Concurrent I/O system, please contact YASKAWA Customer Support at the following 24-hour telephone number:

(937) 847-3200

For **routine** technical inquiries, you can also contact YASKAWA Customer Support at the following e-mail address:

techsupport@motoman.com

When using e-mail to contact YASKAWA Customer Support, please provide a detailed description of your issue, along with complete contact information. Please allow approximately 24 to 36 hours for a response to your inquiry.



Please use e-mail for **routine** inquiries only. If you have an urgent or emergency need for service, replacement parts, or information, you must contact YASKAWA Customer Support at the telephone number shown above.

Please have the following information ready before you call Customer Support:

- | | |
|----------------------------|--|
| • System | Concurrent I/O |
| • Robots | _____ |
| • Primary Application | _____ |
| • Controller | NX100 |
| • Software Version | Access this information on the Programming Pendant's LCD display screen by selecting {MAIN MENU} - {SYSTEM INFO} - {VERSION} |
| • Robot Serial Number | Located on the robot data plate |
| • Robot Sales Order Number | Located on the NX100 controller data plate |

Table of Contents

1	Concurrent I/O	
1.1	Features of Concurrent I/O	1-1
1.2	Construction and Specifications of the Concurrent I/O	1-1
2	Classification of I/O Signals	
2.1	I/O Signals	2-2
■	Meaning of Number	2-2
2.2	Register	2-4
■	General Register	2-4
■	System Register	2-4
■	Analog Output Register	2-5
■	Analog Input Register	2-6
■	Numeric Data	2-6
3	Configuration of I/O Signals	
3.1	Arc Welding	3-1
3.2	Handling, Spot Welding, and General-Purpose Applications	3-2
4	Specific I/O Signals	
4.1	Specific Input Signals for All Applications	4-1
4.2	Specific Input Signals for Arc Welding	4-8
4.3	Specific Input Signals for Handling	4-12
4.4	Specific Input Signals for Spot Welding	4-16
4.5	Specific Input Signals for General-Purpose Applications	4-20

4.6	Specific Input Signals: Explanation	4-24
4.6.1	Alarm and Message Display	4-24
■	40010: SYSTEM ALARM REQUEST	4-24
■	40011: SYSTEM MESSAGE REQUEST	4-25
■	40012: USER ALARM REQUEST	4-25
■	40013: USER MESSAGE REQUEST	4-25
■	40014: ALARM RESET	4-26
4.6.2	Selecting Mode/Cycle and Calling Master Job	4-27
■	40030: MASTER JOB CALLING	4-27
■	40040, 40041: Selection of Modes	4-27
■	40042, 40056, 40057: Selection of Operating Modes	4-27
■	40050 to 40052: Selection of Cycles	4-28
4.6.3	Start and Stop Signals	4-28
■	40044: EXTERNAL START	4-28
■	40045: EXTERNAL SERVO ON	4-28
■	40054, 40065, 40066: EXTERNAL SERVO OFF	4-29
■	40067: EXTERNAL HOLD	4-29
4.6.4	Operating Instructions	4-29
■	40016: In-Guard Safe Operating Instruction	4-29
■	40046: Check Operation	4-29
■	40047: PROHIBIT WEAVING	4-29
■	40053: PLAY MODE ENABLE	4-30
■	40060: MACHINE LOCK	4-30
■	40061: INVALID SHOCK DETECTION	4-30
■	40063: OVERRUN RELEASE REQUEST	4-30
■	40064: EDIT LOCK	4-30
■	40070 to 40073: 1-Step Back Operating Instruction	4-30
■	40090 to 40093: SEQUENCE WAIT	4-30
■	40110 to 40113: Work Home Position Return Request	4-32
■	40337: PP Buzzer	4-33
4.6.5	Independent Control Signals (Optional)	4-33
■	40021 to 40027: SUB 1, 2, 3, 4, 5, 6, 7 ALARM REQUEST	4-33
■	40031 to 40037: SUB1, 2, 3, 4, 5, 6, 7 MASTER CALL	4-33
■	40170 to 40177: SUB 1, 2, 3, 4, 5, 6, 7, and MASTER START REQUEST	4-34
■	40180 to 40187: SUB 1, 2, 3, 4, 5, 6, 7 HOLD REQUEST	4-34
4.6.6	Signals for Arc Welding	4-34
■	40570, 40630, 40690, 40750: WORK START RESPONSE	4-34
■	40571, 40631, 40691, 40751: WORK END RESPONSE	4-34
■	40572, 40632, 40692, 40752: WORK TIME MEASURE	4-34
■	40573, 40633, 40693, 40753: TIP REPLACEMENT COMPLETED	4-35
■	40574, 40634, 40694, 40754: NOZZLE CLEANING COMPLETED	4-35
■	40575, 40635, 40695, 40755: RETRY REQUEST	4-35
■	40576, 40636, 40696, 40756: RETRY RETURN REQUEST	4-35

Table of Contents

■	40577, 40637, 40697, 40757: AUTOMATIC ANTI-STICKING REQUEST	4-35
■	40580, 40640, 40700, 40760: RESTART REQUEST (ARC SHORTAGE)	4-35
■	40581, 40641, 40701, 40761: RESTART REQUEST (GAS SHORTAGE)	4-35
■	40582, 40642, 40702, 40762: RESTART REQUEST (WIRE SHORTAGE).	4-36
■	40583, 40643, 40703, 40763: RESTART RESET PROCESS	4-36
■	40584, 40644, 40704, 40764: RETRY TIMES CLEAR . . .	4-36
■	40585, 40645, 40705, 40766: ARC SHORTAGE RESTART TIMES CLEAR	4-36
■	40586, 40646, 40706, 40766: AUTOMATIC ANTI-STICKING TIMES CLEAR	4-36
■	40600, 40660, 40720, 40780: SENSING PROHIBIT.	4-36
4.6.7	Signals for Handling	4-37
■	40570, 40630, 40690, 40750: WORK START RESPONSE	4-37
■	40571, 40631, 40691, 40751: WORK END RESPONSE . .	4-37
■	40572, 40632, 40692, 40752: WORK TIME MEASURE . .	4-37
■	40580 to 40587, 40640 to 40647, 40700 to 40707, 40760 to 40767: SENSOR INPUT	4-37
4.6.8	Signals for Spot Welding	4-38
■	40572, 40632, 40692, 40752: WORK TIME MEASURE . .	4-38
■	40575, 40585, 40595, 40605: ELECTRODE REPLACEMENT.	4-38
■	40587, 40597, 40607, 40617: WELDING STOP	4-38
4.6.9	Signals for General-Purpose Applications	4-39
■	40570, 40630, 40690, 40750: WORK START RESPONSE	4-39
■	40571, 40631, 40691, 40751: WORK END RESPONSE . .	4-39
■	40572, 40632, 40692, 40752: WORK TIME MEASURE . .	4-39
4.7	Specific Output Signals for All Applications	4-40
4.8	Specific Output Signals for Arc Welding	4-50
4.9	Specific Output Signals for Handling.	4-54
4.10	Specific Output Signals for Spot Welding	4-58
4.11	Specific Output Signals for General-Purpose Applications	4-62
4.12	Specific Output Signals: Explanation	4-66
4.12.1	Alarms and Messages Display	4-66
■	50010 to 50014: ALARM/ERROR OCCURRENCE	4-66
■	50015, 50016: BATTERY WEAK	4-66
■	50017: COOLING FAN ERROR.	4-66
4.12.2	Setting of Mode / Cycle and Particular Play Operation	4-67
■	50050 to 50052: CYCLE SETTING	4-67
■	50053 to 50054: MODE SETTING	4-67
■	50056: COMMAND REMOTE SETTING	4-67
■	50060: IN-GUARD SAFE OPERATION SETTING.	4-67
■	50061: DRY-RUN SETTING.	4-67

■	50062: MACHINE LOCK SETTING	4-67
■	50063: SOFT LIMIT RELEASE SETTING	4-67
■	50064: CHECK RUN SETTING	4-67
4.12.3	Start and Stop Signals	4-67
■	50020: HEAD OF MASTER JOB	4-67
■	50065: PERMISSIBLE WORK IN TEST RUN (FOR ARC ONLY)	4-68
■	50066: POSITION CHECK COMPLETED	4-68
■	50067: FULL SPEED RUNNING	4-68
■	50070: RUNNING (Start Lamp)	4-68
■	50071: HOLDING (Hold Lamp)	4-68
■	50073: SERVO ON	4-68
■	50074: I/O SIMULATED	4-68
■	50075: JOB EDITING OPERATION INDICATION	4-68
■	50076: JOG OPERATION INDICATION	4-68
■	50077: OT RELEASE	4-69
■	50180 to 50197: SERVO ON STATUS	4-69
■	50200, 50201, 50202, 50203: SEQUENCE WAITING	4-69
■	50220, 50221, 50222, 50223: SEQUENCE CONTINUING	4-69
■	50240 to 50243: CONTROL GROUP RUNNING	4-69
■	50260, 50261, 50262, 50283: WORK RESTART PROHIBIT	4-70
■	50264, 50265, 50266, 50267: PERMISSIBLE WORK RUNNING	4-70
■	50270, 50271, 50272, 50273: SEARCH START	4-70
■	50280, 50281, 50282, 50283: LOCUS DEVIATION	4-70
■	50350, 50351, 50352: SECURITY MODE	4-70
■	50354: PLAY MODE ENABLE	4-71
4.12.4	Interference Signals	4-71
■	50080 to 50117: IN-CUBE	4-71
■	50140, 50141, 50150, 50151, 50160, 50161, 50170, 50171: S-AXIS INTERFERENCE AREA	4-71
■	50142, 50144, 50146, 50147, 50152, 50154, 50156, 50157, 50162, 50164, 50166, 50167, 50172 to 50177: MOVING SPHERE INTERFERENCE AREA	4-71
4.12.5	Arithmetic Instruction Signal	4-71
■	50640, 50641, 50642: Arithmetic Flag	4-71
4.12.6	Signals During Operation and for Jog Offset Junction (Optional)	4-72
■	50021, 50022, 50023, 50024, 50025, 50026, 50027: TOP SUB 1, 2, 3, 4, 5, 6, 7 MASTER	4-72
■	50031, 50032, 50033, 50034, 50035, 50036, 50037: SUB HELD	4-72
■	50041, 50042, 50043, 50044, 50045, 50046, 50047: SUB ALARM OCCUR	4-72
■	50143, 50145, 50153, 50155, 50163, 50165: CRD WORKING	4-73
■	50320 to 50327: SUB 1, 2, 3, 4, 5, 6, 7, MASTER OPERATING	4-73
■	50330 to 50337: SUB 1, 2, 3, 4, 5, 6, 7, MASTER HOLDING	4-73

Table of Contents

4.12.7	Signals for Servo Float Function (Optional)	4-73
■	50274, 50275, 50276, 50277: SERVO FLOAT ON	4-73
■	50300 to 50303: SHOCK DETECTION VALID.	4-73
■	50357: SHOCK DTCT ALM	4-73
4.12.8	Singals for Arc Welding	4-74
■	50770, 50830, 50890, 50950: WORK START Instructions	4-74
■	50771, 50831, 50891, 50951: WORK END Instructions.	4-74
■	50772, 50832, 50892, 50952: WORK CONTINUING PROHIBIT Instructions	4-74
■	50773, 50833, 50893, 50953: TIP REPLACEMENT REQUEST	4-74
■	50774, 50834, 50894, 50954: NOZZLE CLEANING REQUEST	4-74
■	50775, 50835, 50895, 50955: INCHING.	4-74
■	50776, 50836, 50896, 50956: RETRACT.	4-75
■	50777, 50837, 50897, 50957: RETRY RETURN PROCESSING	4-75
■	50780, 50840, 50900, 50960: RESTART PROCESSING (ARC SHORTAGE)	4-75
■	50781, 50841, 50901, 50961: RESTART PROCESSING (GAS SHORTAGE)	4-75
■	50782, 50842, 50902, 50962: RESTART PROCESSING (WIRE SHORTAGE).	4-75
■	50783, 50843, 50903, 50963: RESTART RETURN PROCESSING	4-75
■	50784, 50844, 50904, 50964: RETRY SETTING TIME EXCEEDED	4-75
■	50785, 50845, 50905, 50965, : ARC SHORTAGE RESTART SETTING TIMES EXCEEDED	4-76
■	50786, 50846, 50906, 50966: AUTOMATIC ANTI-STICKING SETTING TIMES EXCEEDED	4-76
■	50787, 50847, 50907, 50967: RETRY REPLAY MODE.	4-76
4.12.9	Signals for Handling	4-76
■	50776, 50836, 50896, 50956: SHOCK SENSOR FUNCTION SELECT	4-76
■	50777, 50837, 50897, 50957: SHOCK SENSOR INPUT.	4-76
■	50780 to 50787, 50840 to 50847, 50900 to 50907, 50960 to 50967: TOOL VALVE OUTPUT	4-76
4.12.10	Signals for Spot Welding.	4-77
■	50773, 50783, 50793, 50803: WEAR DETECTION NORMAL	4-77
■	50774, 50784, 50794, 50804: WEAR DETECTION ERROR (Motor Gun)	4-77
■	50775, 50785, 50795, 50805: CHANGE TIP ALM (Motor Gun)	4-77
■	50776, 50786, 50796, 50806: SVSPOT EXECUTE (Motor Gun)	4-77
■	50777: WELDING ON/OFF	4-77
■	50780, 50790, 50800, 50810: SENSOR DETECTING.	4-77

4.12.11	Signals for General-Purpose Applications	4-77
■	50770, 50830, 50890, 50950: WORK START Instructions .	4-78
■	50771, 50831, 50891, 50951: WORK END Instructions . .	4-78
■	50772, 50832, 50892, 50952: WORK CONTINUING PROHIBIT Instructions	4-78
5	Internal Signal Used in Standard Ladder	
5.1	Signals for Arc Welding	5-1
5.2	Signals for Handling	5-3
5.3	Signals for Spot Welding	5-4
5.4	Signals for General-Purpose Applications	5-6
6	Internal Control Status Signals	
6.1	Internal Control Status Signals	6-1
6.1.1	Internal Control Status Signal (Monitor)	6-4
■	80010: EDITING PROHIBITION	6-4
■	80011 to 80013: MODE SELECTION	6-4
■	80015: *PROGRAMMING PENDANT PANEL HOLD	6-4
■	80016: OPERATION START	6-4
■	80017: SERVO POWER ON	6-4
■	80023: *SAFETY PLUG INPUT	6-5
■	80024: *NCP01 CPU ERROR	6-5
■	80025: *EXTERNAL EMERGENCY STOP	6-5
■	80026: *PROGRAMMING PENDANT EMERGENCY STOP	6-5
■	80027: * NX100 DOOR EMERGENCY STOP	6-5
■	80031: SERVO ON CONDITION 1	6-5
■	80032: MAINTENANCE INPUT	6-5
■	80033: SERVO ON CONDITION 2	6-6
■	80034: DEADMAN SWITCH INPUT	6-6
■	80035: *EXTERNAL HOLD	6-6
■	80036: EXTERNAL DEADMAN SWITCH INPUT	6-6
■	80037: EXTERNAL SERVO ON INPUT	6-6
■	80040: SAFE SPEED 2	6-6
■	80041: SAFE SPEED 1	6-6
■	80046: SAFE SPEED MODE SELECT	6-6
■	80047: FULL-SPEED TEST	6-7
■	80050: 24V OK	6-7
■	80051: EXTERNAL 24V OK	6-7
■	80060: *SHOCK SENSOR OPERATION HOLD	6-7
■	80061: *SERVO ON ENABLED	6-7
■	80062: *BRAKE FUSE BLOWN-OFF	6-7
■	80064: *SERVO CPU ERROR	6-7
■	80065: *SHOCK SENSOR OPERATION EMERGENCY STOP	6-7

Table of Contents

■	80066: *EXTERNAL AXIS OVERTRAVEL	6-7
■	80067: *OVERTRAVEL	6-8
■	80070 to 80073: DIRECT IN (SYSTEM) 1 to 4.	6-8
■	80080 to 80084: DIRECT IN (SERVO) 1 to 5.	6-8
7	Pseudo Input Signals	
	7.1 Pseudo Input Signals.	7-1
	■ 82014 to 82016: REMOTE FUNCTION SELECTION	7-1
	■ 82020 to 82027: SIGNAL SELECT STATUS (SPOT WELDING)	7-1
8	Network I/O Signals	
9	Interface Panel Signals	
10	I/O Except Concurrent I/O	
	10.1 Hardware Specific Input	10-1
	10.2 I/O Except Concurrent I/O: Explanation	10-3
	■ EXESP: FOR EXTERNAL EMERGENCY STOP	10-3
	■ EXHOLD: FOR EXTERNAL HOLD	10-3
	■ SAFF: FOR SAFETY PLUG	10-3
	■ EXSVON: FOR EXTERNAL SERVO ON	10-3
	■ CPDIN1 to 4: FOR DIRECT IN (SYSTEM) INPUT SIGNAL 1 to 4.	10-3
	■ AXDIN1 to 5: FOR DIRECT IN (SERVO) INPUT SIGNAL 1 to 5.	10-4
	■ MAINT: MAINTENANCE INPUT SIGNAL	10-4
11	Register	
	11.1 Common Usage for All Applications.	11-1
	11.1.1 General Register	11-1
	11.1.2 System Register.	11-3
	11.2 Arc Welding	11-5
	11.3 Handling.	11-6
	11.4 General Purposes	11-7
	11.5 Spot Welding	11-8

12 Standard Ladder Program

12.1	List of Usable Instructions	12-1
12.2	Instruction Description	12-6
	■ STR Instruction	12-6
	■ STR-NOT Instruction	12-6
	■ AND Instruction	12-7
	■ AND-NOT Instruction	12-7
	■ OR Instruction	12-8
	■ OR-NOT Instruction	12-8
	■ AND-STR Instruction	12-9
	■ OR-STR Instruction	12-9
	■ OUT Instruction	12-10
	■ PART Instruction	12-10
	■ END Instruction	12-11
	■ TMR Instruction	12-11
	■ CNT Instruction	12-12
	■ GSTR Instruction / GOUT Instruction	12-14
	■ PLS Instruction	12-14
	■ PLF Instruction	12-15
	■ ADD Instruction	12-16
	■ SUB Instruction	12-17
	■ MUL Instruction	12-18
	■ DIV Instruction	12-19
	■ MOD Instruction	12-20
	■ BIN Instruction	12-21
	■ BCD Instruction	12-22
	■ MOV Instruction	12-23
	■ WAND Instruction	12-24
	■ WOR Instruction	12-25
	■ WXOR Instruction	12-26
	■ WNOT Instruction	12-27
	■ SHL Instruction	12-28
	■ SHR Instruction	12-29
	■ ROL Instruction	12-30
	■ ROR Instruction	12-31
12.3	Arithmetic Flag	12-32
	■ Flag Type	12-32
	■ Flag Transition under Scanning	12-32
12.4	Arc Welding	12-33
	■ Ladder Program List	12-33
	■ I/O Alarm	12-65
	■ I/O Message	12-66
	■ USER OPEN SIGNALS	12-67
12.5	Handling	12-69
	■ LADDER PROGRAM LIST	12-69
	■ I/O ALARM	12-86
	■ I/O Message	12-87

Table of Contents

12.6	Spot Welding	12-88
■	Ladder Program List	12-88
■	I/O Alarm	12-106
■	I/O Message	12-107
12.7	General-Purpose Applications	12-108
■	LADDER PROGRAM LIST	12-108
■	I/O ALARM	12-124
■	I/O MESSAGE	12-125

13 How to Monitor Signals

13.1	Monitoring I/O Signals.....	13-1
13.1.1	I/O Windows.....	13-1
13.2	I/O Status Window.....	13-3
13.2.1	Universal Output Window.....	13-5
13.2.2	Universal Input Window	13-6
13.2.3	Changing Signal Status from the External Output Window	13-10
13.2.4	Changing Signal Status from the External Input Window..	13-13
13.3	Pseudo Input Signal Window	13-16
13.4	Register Window.....	13-19
13.5	Servo Power Status Window.....	13-23
13.6	Analog Output Window	13-24
13.7	I/O Messages and I/O Alarms	13-25
13.7.1	Registering the User Section	13-25
13.8	Ladder Program Window	13-27

14 Editing Ladder Programs

14.1	Flow of Data by Ladder Programs.....	14-1
14.2	Editing by Mnemonic and Ladder Editor Program	14-2
14.3	Mnemonic Editing Window	14-3
14.3.1	Basic Operation	14-3
14.3.2	Editing Operation	14-5
■	Inserting Instruction	14-5
■	Changing Instructions.....	14-8
■	Delete Instructions	14-10
■	Editing Operands	14-11
■	Cancelling Editing.....	14-12
14.3.3	Compile	14-13

14.3.4 Search.....	14-14
■ Top Line, End Line	14-15
■ Search for Line No. and Block No.	14-15
■ Search for Relay No. and Register No.....	14-16

15 Clearing Signals

15.1 Clearing the Universal Output Signals.....	15-1
■ Clearing Signals when Powering ON	15-1
■ Clearing Signals when Changing the Teach/Play Mode...	15-1
15.2 Clearing the Interface Panel Signals	15-3
■ Clearing Signals when Powering ON	15-3
15.3 Clearing the Auxiliary Relay Signals.....	15-4
■ Clearing Signals when Powering ON	15-4
15.4 Clearing the Universal Register	15-7
■ Clearing Registers when Powering ON.....	15-7

1 Concurrent I/O

Concurrent I/O control is an I/O control function that processes controls relative to the NX100 I/O independent of the manipulator operation (in parallel with manipulator operation).

1.1 Features of Concurrent I/O

Terminals and connectors to which I/O signals are connected can be used effectively.

Terminals and connectors are provided for connecting I/O signals. Although the number of connections are limited, the terminals can be used effectively because only the necessary signals can be selected and connected to the desired terminal.

Instructions relative to the I/O (Robot Language: INFORM III) can be simplified for smooth manipulator operation.

Fixed procedures relative to the I/O can be registered as independent ladder programs, thus enabling simplification of I/O instructions of the job (operation program) and reducing interruptions.

Reserved signals can be accepted while the manipulator is operating.

Reserved signals can be accepted during operation since manipulator operation processing and I/O processing can be executed at the same time.

1.2 Construction and Specifications of the Concurrent I/O

The Concurrent I/O consists of the following two blocks.

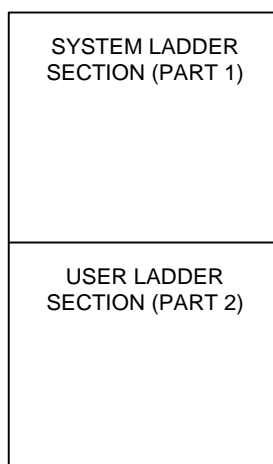

Construction of Concurrent I/O Ladder Program

System Ladder Section A standard ladder selected for your applications is prepared at the factory. For more information, see "11 Standard Ladder Program" The ladder program cannot be edited.

1.2 Construction and Specifications of the Concurrent I/O

User Ladder Section Specification of signal connections and interface signal with system ladder are prepared at the factory. The ladder program can be edited including these signals.

Concurrent I/O Specifications

Item	Contents
Control Method	Scan control by stored program
Programming	Relay ladder program symbology
Scan Time	10 msec
Memory Capacity	10000 steps (Up to 15000 steps: optional)
Number of Instructions	33 types
General Input Port	1024 points (Concurrent I/O → Manipulator Control Section)
General Output Port	1024 points (Concurrent I/O ← Manipulator Control Section)
Specific Input Port	640 points including unspecified signals (Concurrent I/O → Manipulator Control Section)
Specific Output Port	800 points including unspecified signals (Concurrent I/O ← Manipulator Control Section)
Hardware Status Signal Points	512 points (Concurrent I/O → Manipulator Control Section)
Auxiliary Relays	7992 points
External Inputs	1024 points
External Outputs	1024 points
Register (Numeric Data)	General Register 260 points (0-65535) System Register 160 points (0-65535) Analog output register 40 points (0-65535) Analog input register 40 points (0-65535)
Pseudo Input Signal Points	96 points (Concurrent I/O ← System Parameter)
Power Failure Protective Function	Ladder Program (Battery Back-Up) Output status is reset.

1 Concurrent I/O

1.2 Construction and Specifications of the Concurrent I/O

Concurrent I/O Specifications

Item	Contents
Diagnostic Functions	Error Detection of CPU, system program and ladder programs. Ladder programming error detection as follows: <ul style="list-style-type: none"> • Double Use of Output Relay • No END Instruction • Circuit Error • Format Error • Exceeded Program Capacity
Monitor Function	Monitor each signal status in concurrent I/O on CRT window.



Although the scan time is as mentioned above, please keep ON or OFF status of the inputting signal sufficiently longer than the scan time so that the signal is correctly recognized.

2 Classification of I/O Signals

Classification of I/O signals

Logic Name	Classification	Description	Range
0 xxxx	General Input	Referenced with input instruction of the job	00010 - 01287 (1024 signals)
1 xxxx	General Output	Referenced with output instruction of the job	10010 - 11287 (1024 signals)
2 xxxx	External Input	Signal No. corresponding to the input terminal	20010 - 21287 (1024 signals)
3 xxxx	External Output	Signal No. corresponding to the output terminal	30010 - 31287 (1024 signals)
4 xxxx	Specific Input	Signal to change the operating condition of the robot	40010 - 40807 (640 signals)
5 xxxx	Specific Output	Signal notifying the operating condition of the robot	50010 - 51007 (800 signals)
6 xxxx	Interface Panel Input	Signal notifying the operating condition of the interface panel	60010 - 60647 (512 signals)
7 xxxx	Auxiliary Relay	Auxiliary relay in the concurrent I/O	70010 - 79997 (7992 signals)
80 xxx	Control Status	Monitoring of the hardware signal status of the robot control section	80010 - 80647 (512 signals)
82 xxx	Pseudo Input	Pseudo input relay reading from the system parameter	82010 - 82127 (96 signals)
22 xxx	Network Input	Input signal from the network device	22010 - 23287 (1024 signals)
32 xxx	Network Output	Input signal to the network device	32010 - 33287 (1024 signals)
M xxx	Register	1 word data (16 bits) General Register: M000 - M259 Analog Output Register: M260 - M299 Analog Input Register: M300 - M339 System Register: M340 - M499	M000 - M499 (500 signals)

2 Classification of I/O Signals

2.1 I/O Signals

■ Meaning of Number

The I/O processing part and the manipulator operation processing part are connected by "Logical I/O". However, for the function, they are separated as a quite independent function. How to handle each signal is also different from the manipulator operation processing part.

In ladder programming, to specify each signal unitedly, the number is set to as follows. "Relay number" is specified by the numerical value of five digits. This numerical value is composed of the following three information.

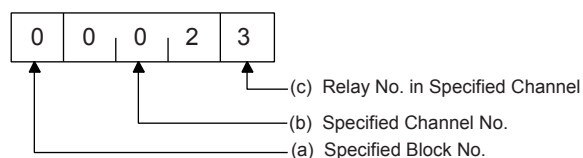

Specified Block Number

This is divided into the following block.

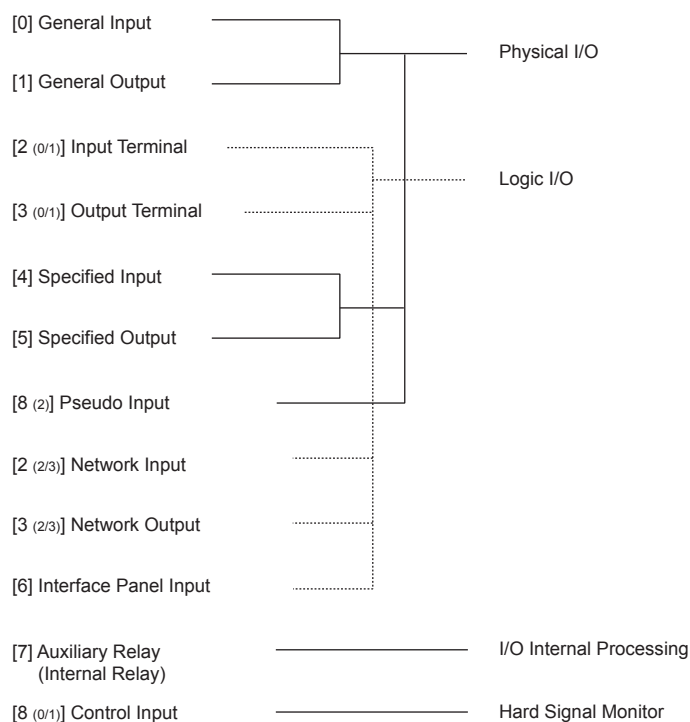

Specified Channel Number

Eight signals are defined as one channel.

[001] Last eight signals



[nnn] Last eight signals

Refer to the under mentioned table for concrete channel number.

Relay Number in Specified Channel

One of eight signals is specified by numerical value (0-7).

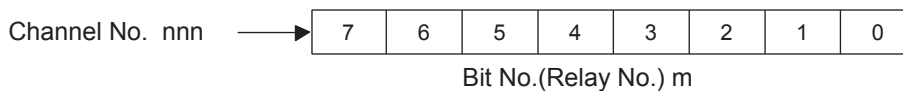

As for each block, a minimum digit is specified by the numerical value to 0-7 for a relay number as understood from the table. In a word, it is a serial number which omits 8 and 9.

Moreover, the first relay number of each block starts from xxx10 because channel number enters between digits of 10, 100, and 1000.

The relay number will be specified by the numerical value of the fifth digit in the frame.

Block Number: 0

Relay Number: 0 nnn m

nn: Channel01 →	00019	00018	00017	00016	00015	00014	00013	00012	00011	00010
Channel02 →	00029	00028	00027	00026	00025	00024	00023	00022	00021	00020
Channel03 →	00039	00038	00037	00036	00035	00034	00033	00032	00031	00030
Channel04 →	00049	00048	00047	00046	00045	00044	00043	00042	00041	00040
Channel05 →	00059	00058	00057	00056	00055	00054	00053	00052	00051	00050
Channel06 →	00069	00068	00067	00066	00065	00064	00063	00062	00061	00060

↑ There are no relays which correspond to these numbers.
(These numbers cannot be used.)



The relay is occasionally treated by the units (8 bits) of the byte (channel) or the units (16 bits) of the word.

2 Classification of I/O Signals

2.2 Register

2.2 Register

The register is data of each every word (16 bits).

General register (M000 - M259) and analog output register (M260 - M299) are readable and writable. System register (M340 - M499) and analog input register (M300 - M339) are readable only, and the data is set by the system.



The register is treated by the unit of one word (16 bits). Therefore, it is not possible to handle it by the bit specification instruction (STR, AND, OR, and OUT, etc.) and the PLS instructions, etc.

■ General Register

This is composed of one word (16 bits).

Bit	15	14	13	12	11	10	9	8	7	6	5	4	3	2	1	0
M000																
M001																
:																
M259																

■ System Register

This is composed of one word (16 bits).

Bit	15	14	13	12	11	10	9	8	7	6	5	4	3	2	1	0
M340																
M341																
:																
M499																

■ Analog Output Register

This is composed of one word (16 bits). The analog output registers (M260 - M299) correspond to the analog outputs 1 to 40. Since an analog output board with different digital resolution (D/A circuit) is used in common with the analog output register, the data below the resolution is cut off at output.

Analog output	Bit	15	14	13	12	11	10	9	8	7	6	5	4	3	2	1	0
AOUT01	M260																
AOUT02	M261																
:	:																
AOUT40	M299																

Resolution and Valid Data

- 8-bit resolution : Bit 8 to Bit 15 are valid data.
- 12-bit resolution: Bit 4 to Bit 15 are valid data.
- 16-bit resolution: Bit 0 to Bit 15 are valid data.

Resolution	Bit	15	14	13	12	11	10	9	8	7	6	5	4	3	2	1	0
8-bit		■	■	■	■	■	■	■	■								
12-bit		■	■	■	■	■	■	■	■	■	■	■					
16-bit		■	■	■	■	■	■	■	■	■	■	■	■	■	■	■	■

Regardless of the resolution, the register value per 1 V is:
 $1 \text{ (V)} = 32767 \text{ (7fffH)} / 14 \text{ (V)} \doteq 2340 \text{ (924H)}$

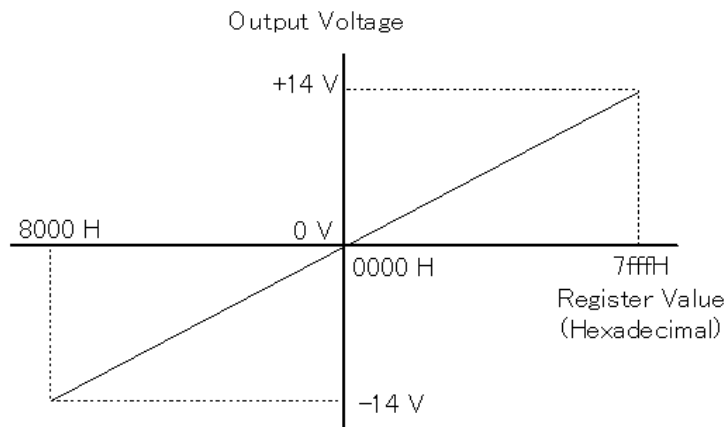

Analog output board (JANCD-NEW01-□, JANCD-XEW01-□, JANCD-XEW02) uses a 12-bit resolution D/A circuit.

2 Classification of I/O Signals

2.2 Register

■ Analog Input Register

This is composed of one word (16 bits). The analog input registers (M300 - M339) correspond to the analog inputs 1 to 40.

Analog input	Bit	15	14	13	12	11	10	9	8	7	6	5	4	3	2	1	0
AIN01	M300																
AIN02	M301																
:	:																
AIN40	M339																

The register value per 1 V is:

$$1 \text{ (V)} = 32767 \text{ (7fffH)} / 5 \text{ (V)} \doteq 6553 \text{ (1999H)}$$

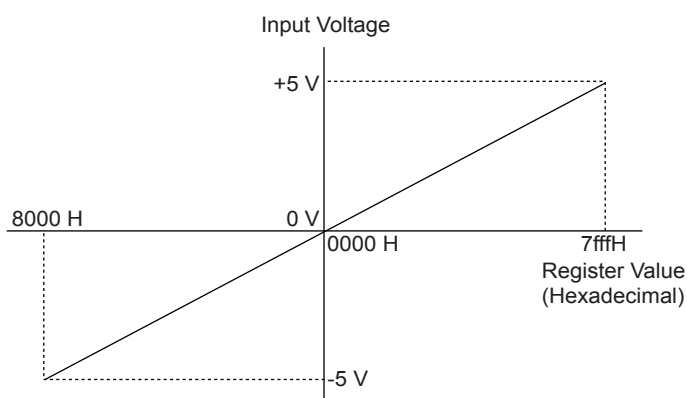

■ Numeric Data

Binary number is the one that the numeric data was expressed by 1(ON) and 0(OFF). Internal data of a usual computer is expressed by the binary number. On the other hand, BCD (Binary Code Decimal) makes one digit of the decimal number by using four bits of the binary number, that is, four digits, combines these, and shows the decimal number. The equipment connected with NX100 occasionally uses BCD as an input and a output signal. When transferring the data between these, it is necessary to convert BCD into the binary number when NX100 receives the data, and it is necessary to convert the binary number into BCD when outputting the data to the equipment. It is possible to convert the data by BIN and the BCD instruction in the concurrent I/O function.

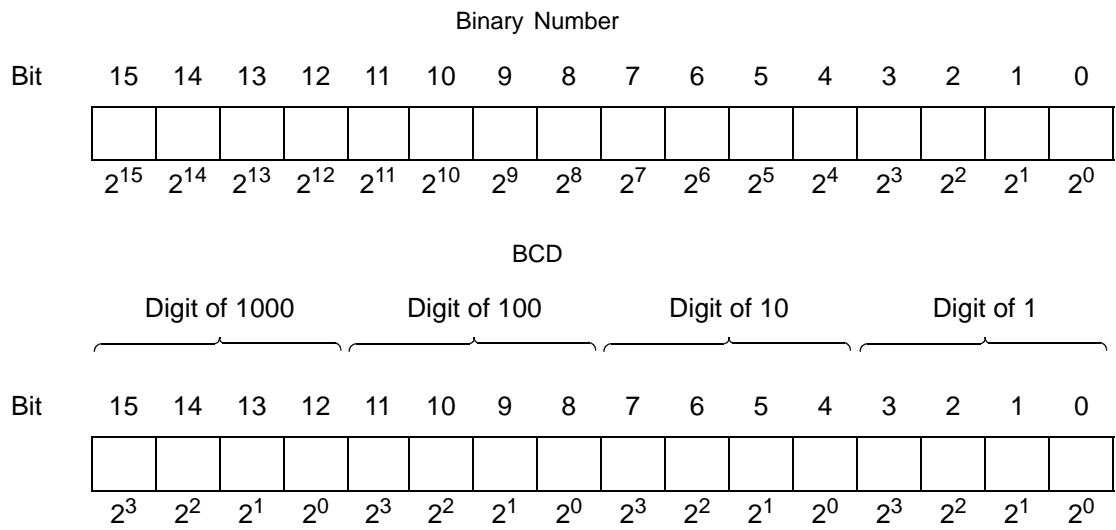

Binary number and BCD expression of the decimal number

Decimal Number	Binary	BCD
1	0000 0000 0000 0001	0000 0000 0000 0001
12	0000 0000 0000 1100	0000 0000 0001 0010
123	0000 0000 0111 1011	0000 0001 0010 0011
1234	0000 0100 1101 0010	0001 0010 0011 0100

3 Configuration of I/O Signals

3.1 Arc Welding

3 Configuration of I/O Signals

3.1 Arc Welding

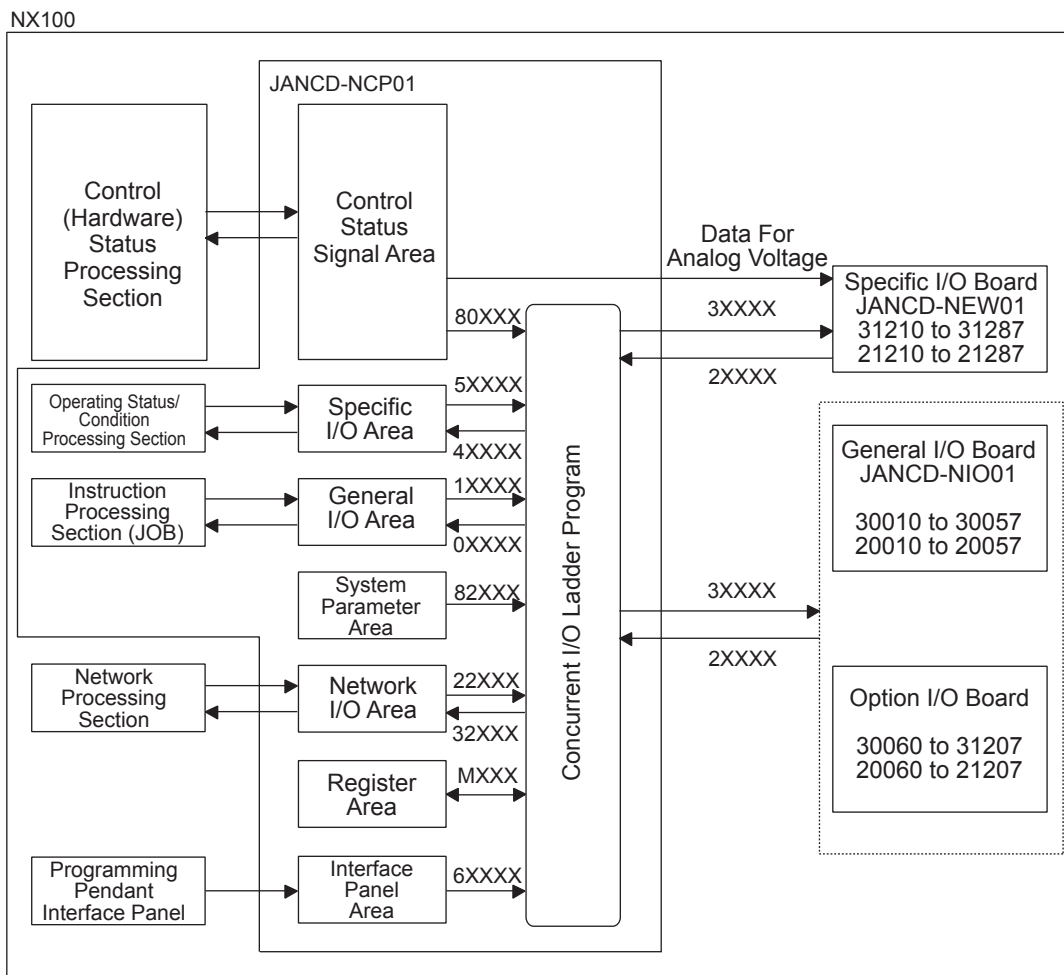

How to Monitor Signal Status

To monitor a signal, verify the signal status of the signal logic number in the I/O monitor window (refer to section 13.1.1 "I/O Windows").

3.2 Handling, Spot Welding, and General-Purpose Applications

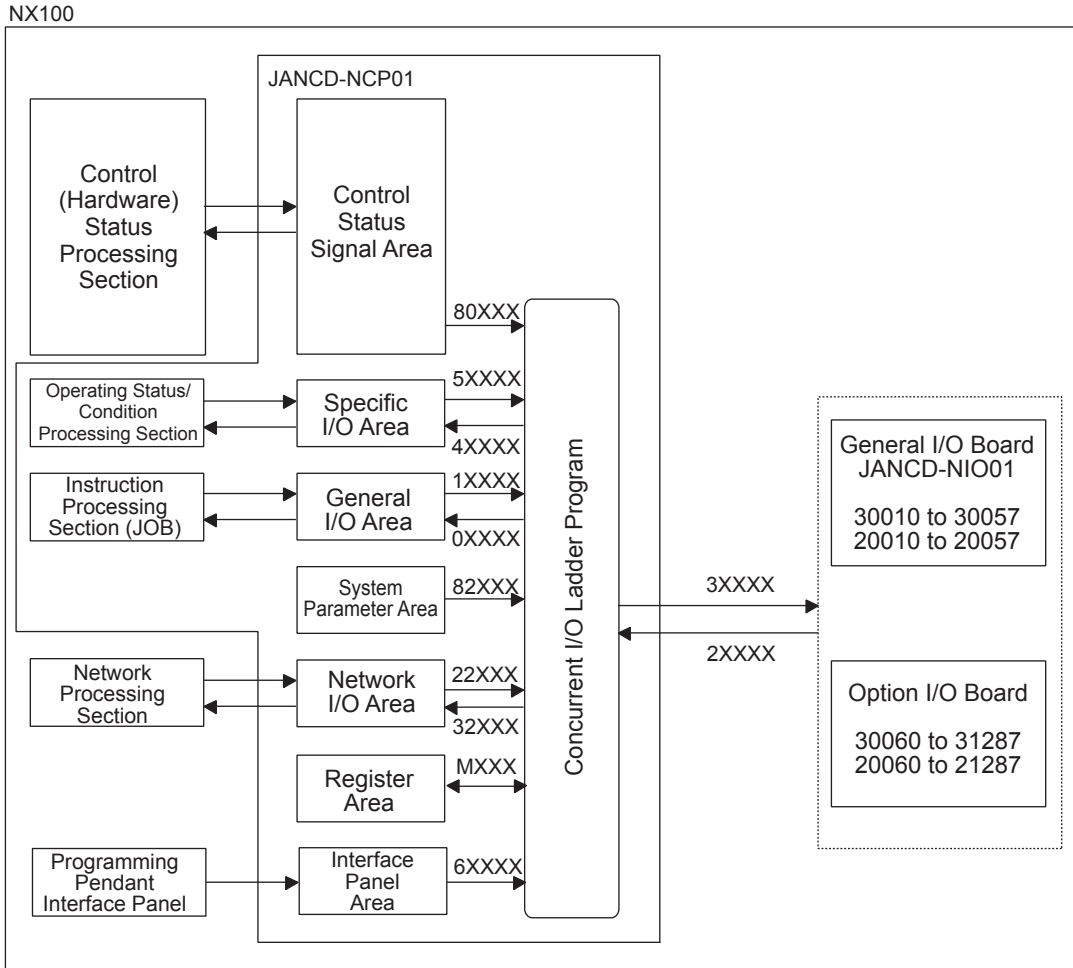

How to Monitor Signal Status

To monitor a signal, verify the signal status of the signal logic number in the I/O monitor window (refer to section 13.1.1 "I/O Windows").

4 Specific I/O Signals

4.1 Specific Input Signals for All Applications

4 Specific I/O Signals

4.1 Specific Input Signals for All Applications

40017	40016	40015	40014	40013	40012	40011	40010
SIN#008	SIN#007	SIN#006	SIN#005	SIN#004	SIN#003	SIN#002	SIN#001
	SAFETY SPEED		ALARM RESET	USER MESSAGE REQUEST	USER ALARM REQUEST	SYSTEM MESSAGE REQUEST	SYSTEM ALARM REQUEST

40027	40026	40025	40024	40023	40022	40021	40020
SIN#016	SIN#015	SIN#014	SIN#013	SIN#012	SIN#011	SIN#010	SIN#009
SUB TASK 7 ALARM REQUEST	SUB TASK 6 ALARM REQUEST	SUB TASK 5 ALARM REQUEST	SUB TASK 4 ALARM REQUEST	SUB TASK 3 ALARM REQUEST	SUB TASK 2 ALARM REQUEST	SUB TASK 1 ALARM REQUEST	

40037	40036	40035	40034	40033	40032	40031	40030
SIN#024	SIN#023	SIN#022	SIN#021	SIN#020	SIN#019	SIN#018	SIN#017
SUB MASTER JOB 7 CALL	SUB MASTER JOB 6 CALL	SUB MASTER JOB 5 CALL	SUB MASTER JOB 4 CALL	SUB MASTER JOB 3 CALL	SUB MASTER JOB 2 CALL	SUB MASTER JOB 1 CALL	MASTER JOB CALL

40047	40046	40045	40044	40043	40042	40041	40040
SIN#032	SIN#031	SIN#030	SIN#029	SIN#028	SIN#027	SIN#026	SIN#025
PROHIBIT WEAVING	CHECK RUN	EXT SERVO ON	EXT START		CMD REMOTE SELECT	PLAY MODE SEL	TEACH MODE SEL

40057	40056	40055	40054	40053	40052	40051	40050
SIN#040	SIN#039	SIN#038	SIN#037	SIN#036	SIN#035	SIN#034	SIN#033
PROHIBIT I/O	PROHIBIT PP		EXT SERVO OFF 3 (E-STOP CATEGORY 1)	PLAY MODE ENABLE	CONTINUE CYCLE SELECT	1 CYCLE SELECT	STEP CYCLE SELECT

40067	40066	40065	40064	40063	40062	40061	40060
SIN#048	SIN#047	SIN#046	SIN#045	SIN#044	SIN#043	SIN#042	SIN#041
EXT HOLD	EXT SERVO OFF 2 (E-STOP CATEGORY 0)	EXT SERVO OFF 1	EDIT LOCK	OT RELEASE REQ		SHOCK DETECTION INVALID	MACHINE LOCK

40077	40076	40075	40074	40073	40072	40071	40070
SIN#056	SIN#055	SIN#054	SIN#053	SIN#052	SIN#051	SIN#050	SIN#049
				STEPBACK R4J	STEPBACK R3J	STEPBACK R2J	STEPBACK R1J

4 Specific I/O Signals
4.1 Specific Input Signals for All Applications

40087	40086	40085	40084	40083	40082	40081	40080
SIN#064	SIN#063	SIN#062	SIN#061	SIN#060	SIN#059	SIN#058	SIN#057

40097	40096	40095	40094	40093	40092	40091	40090
SIN#072	SIN#071	SIN#070	SIN#069	SIN#068	SIN#067	SIN#066	SIN#065
				WAIT JOB SEQ R4J	WAIT JOB SEQ R3J	WAIT JOB SEQ 2J	WAIT JOB SEQ R1J

40107	40106	40105	40104	40103	40102	40101	40100
SIN#080	SIN#079	SIN#078	SIN#077	SIN#076	SIN#075	SIN#074	SIN#073

40117	40116	40115	40114	40113	40112	40111	40110
SIN#088	SIN#087	SIN#086	SIN#085	SIN#084	SIN#083	SIN#082	SIN#081
				OPE ORG RET R4	OPE ORG RET R3	OPE ORG RET R2	OPE ORG RET R1

40127	40126	40125	40124	40123	40122	40121	40120
SIN#096	SIN#095	SIN#094	SIN#093	SIN#092	SIN#091	SIN#090	SIN#089

40137	40136	40135	40134	40133	40132	40131	40130	
SIN#104	SIN#103	SIN#102	SIN#101	SIN#100	SIN#099	SIN#098	SIN#097	
			SYSTEM ALARM CODE (BINARY)					
		d5	d4	d3	d2	d1	d0	

40147	40146	40145	40144	40143	40142	40141	40140	
SIN#112	SIN#111	SIN#110	SIN#109	SIN#108	SIN#107	SIN#106	SIN#105	
			USER ALARM CODE (BINARY)					
		d5	d4	d3	d2	d1	d0	

40157	40156	40155	40154	40153	40152	40151	40150	
SIN#120	SIN#119	SIN#118	SIN#117	SIN#116	SIN#115	SIN#114	SIN#113	
			SYSTEM MESSAGE CODE (BINARY)					
		d5	d4	d3	d2	d1	d0	

4 Specific I/O Signals

4.1 Specific Input Signals for All Applications

40167	40166	40165	40164	40163	40162	40161	40160
SIN#128	SIN#127	SIN#126	SIN#125	SIN#124	SIN#123	SIN#122	SIN#121
			USER MESSAGE CODE (BINARY)				
		d5	d4	d3	d2	d1	d0

40177	40176	40175	40174	40173	40172	40171	40170
SIN#136	SIN#135	SIN#134	SIN#133	SIN#132	SIN#131	SIN#130	SIN#129
SUB TASK 7 START REQUEST	SUB TASK 6 START REQUEST	SUB TASK 5 START REQUEST	SUB TASK 4 START REQUEST	SUB TASK 3 START REQUEST	SUB TASK 2 START REQUEST	SUB TASK 1 START REQUEST	MASTER JOB START REQUEST

40187	40186	40185	40184	40183	40182	40181	40180
SIN#144	SIN#143	SIN#142	SIN#141	SIN#140	SIN#139	SIN#138	SIN#137
SUB TASK 7 HOLD REQUEST	SUB TASK 6 HOLD REQUEST	SUB TASK 5 HOLD REQUEST	SUB TASK 4 HOLD REQUEST	SUB TASK 3 HOLD REQUEST	SUB TASK 2 HOLD REQUEST	SUB TASK 1 HOLD REQUEST	MASTER JOB HOLD REQUEST

40197	40196	40195	40194	40193	40192	40191	40190
SIN#152	SIN#151	SIN#150	SIN#149	SIN#148	SIN#147	SIN#146	SIN#145

40207	40206	40205	40204	40203	40202	40201	40200
SIN#160	SIN#159	SIN#158	SIN#157	SIN#156	SIN#155	SIN#154	SIN#153

40217	40216	40215	40214	40213	40212	40211	40210
SIN#168	SIN#167	SIN#166	SIN#165	SIN#164	SIN#163	SIN#162	SIN#161

40227	40226	40225	40224	40223	40222	40221	40220
SIN#176	SIN#175	SIN#174	SIN#173	SIN#172	SIN#171	SIN#170	SIN#169

40237	40236	40235	40234	40233	40232	40231	40230
SIN#184	SIN#183	SIN#182	SIN#181	SIN#180	SIN#179	SIN#178	SIN#177

40247	40246	40245	40244	40243	40242	40241	40240
SIN#192	SIN#191	SIN#190	SIN#189	SIN#188	SIN#187	SIN#186	SIN#185

4 Specific I/O Signals
4.1 Specific Input Signals for All Applications

40257	40256	40255	40254	40253	40252	40251	40250
SIN#200	SIN#199	SIN#198	SIN#197	SIN#196	SIN#195	SIN#194	SIN#193

40267	40266	40265	40264	40263	40262	40261	40260
SIN#208	SIN#207	SIN#206	SIN#205	SIN#204	SIN#203	SIN#202	SIN#201

40277	40276	40275	40274	40273	40272	40271	40270
SIN#216	SIN#215	SIN#214	SIN#213	SIN#212	SIN#211	SIN#210	SIN#209

40287	40286	40285	40284	40283	40282	40281	40280
SIN#224	SIN#223	SIN#222	SIN#221	SIN#220	SIN#219	SIN#218	SIN#217

40297	40296	40295	40294	40293	40292	40291	40290
SIN#232	SIN#231	SIN#230	SIN#229	SIN#228	SIN#227	SIN#226	SIN#225

40307	40306	40305	40304	40303	40302	40301	40300
SIN#240	SIN#239	SIN#238	SIN#237	SIN#236	SIN#235	SIN#234	SIN#233

40317	40316	40315	40314	40313	40312	40311	40310
SIN#248	SIN#247	SIN#246	SIN#245	SIN#244	SIN#243	SIN#242	SIN#241

40327	40326	40325	40324	40323	40322	40321	40320
SIN#256	SIN#255	SIN#254	SIN#253	SIN#252	SIN#251	SIN#250	SIN#249

4 Specific I/O Signals

4.1 Specific Input Signals for All Applications

40337	40336	40335	40334	40333	40332	40331	40330
SIN#264	SIN#263	SIN#262	SIN#261	SIN#260	SIN#259	SIN#258	SIN#257
PP BUZZER							

40347	40346	40345	40344	40343	40342	40341	40340
SIN#272	SIN#271	SIN#270	SIN#269	SIN#268	SIN#267	SIN#266	SIN#265

40357	40356	40355	40354	40353	40352	40351	40350
SIN#280	SIN#279	SIN#278	SIN#277	SIN#276	SIN#275	SIN#274	SIN#273

40367	40366	40365	40364	40363	40362	40361	40360
SIN#288	SIN#287	SIN#286	SIN#285	SIN#284	SIN#283	SIN#282	SIN#281

40377	40376	40375	40374	40373	40372	40371	40370
SIN#296	SIN#295	SIN#294	SIN#293	SIN#292	SIN#291	SIN#290	SIN#289

40387	40386	40385	40384	40383	40382	40381	40380
SIN#304	SIN#303	SIN#302	SIN#301	SIN#300	SIN#299	SIN#298	SIN#297

40397	40396	40395	40394	40393	40392	40391	40390
SIN#312	SIN#311	SIN#310	SIN#309	SIN#308	SIN#307	SIN#306	SIN#305

40407	40406	40405	40404	40403	40402	40401	40400
SIN#320	SIN#319	SIN#318	SIN#317	SIN#316	SIN#315	SIN#314	SIN#313

4 Specific I/O Signals
4.1 Specific Input Signals for All Applications

40417	40416	40415	40414	40413	40412	40411	40410
SIN#328	SIN#327	SIN#326	SIN#325	SIN#324	SIN#323	SIN#322	SIN#321

40427	40426	40425	40424	40423	40422	40421	40420
SIN#336	SIN#335	SIN#334	SIN#333	SIN#332	SIN#331	SIN#330	SIN#329

40437	40436	40435	40434	40433	40432	40431	40430
SIN#344	SIN#343	SIN#342	SIN#341	SIN#340	SIN#339	SIN#338	SIN#337

40447	40446	40445	40444	40443	40442	40441	40440
SIN#352	SIN#351	SIN#350	SIN#349	SIN#348	SIN#347	SIN#346	SIN#345

40457	40456	40455	40454	40453	40452	40451	40450
SIN#360	SIN#359	SIN#358	SIN#357	SIN#356	SIN#355	SIN#354	SIN#353

40467	40466	40465	40464	40463	40462	40461	40460
SIN#368	SIN#367	SIN#366	SIN#365	SIN#364	SIN#363	SIN#362	SIN#361

40477	40476	40475	40474	40473	40472	40471	40470
SIN#376	SIN#375	SIN#374	SIN#373	SIN#372	SIN#371	SIN#370	SIN#369

40487	40486	40485	40484	40483	40482	40481	40480
SIN#384	SIN#383	SIN#382	SIN#381	SIN#380	SIN#379	SIN#378	SIN#377

4 Specific I/O Signals

4.1 Specific Input Signals for All Applications

40497	40496	40495	40494	40493	40492	40491	40490
SIN#392	SIN#391	SIN#390	SIN#389	SIN#388	SIN#387	SIN#386	SIN#385

40507	40506	40505	40504	40503	40502	40501	40500
SIN#400	SIN#399	SIN#398	SIN#397	SIN#396	SIN#395	SIN#394	SIN#393

40517	40516	40515	40514	40513	40512	40511	40510
SIN#408	SIN#407	SIN#406	SIN#405	SIN#404	SIN#403	SIN#402	SIN#401

40527	40526	40525	40524	40523	40522	40521	40520
SIN#416	SIN#415	SIN#414	SIN#413	SIN#412	SIN#411	SIN#410	SIN#409

40537	40536	40535	40534	40533	40532	40531	40530
SIN#424	SIN#423	SIN#422	SIN#421	SIN#420	SIN#419	SIN#418	SIN#417

40547	40546	40545	40544	40543	40542	40541	40540
SIN#440	SIN#439	SIN#438	SIN#437	SIN#436	SIN#435	SIN#434	SIN#433

40557	40556	40555	40554	40553	40552	40551	40550
SIN#448	SIN#447	SIN#446	SIN#445	SIN#444	SIN#443	SIN#442	SIN#441

40567	40566	40565	40564	40563	40562	40561	40560
SIN#456	SIN#455	SIN#454	SIN#453	SIN#452	SIN#451	SIN#450	SIN#449

4.2 Specific Input Signals for Arc Welding

Device 1

40577	40576	40575	40574	40573	40572	40571	40570
SIN#456	SIN#455	SIN#454	SIN#453	SIN#452	SIN#451	SIN#450	SIN#449
ANTI-STICK REQUEST	RETRY RET REQUEST	RETRY REQUEST	NOZZLE CLEANED	TIP CHANGED	TIME MEASURE	WORKEND ANSWER	WORK START ANSWER

40587	40586	40585	40584	40583	40582	40581	40580
SIN#464	SIN#463	SIN#462	SIN#461	SIN#460	SIN#459	SIN#458	SIN#457
	CLEAR ANTI-STICCK NO	CLEAR RESTART NO	CLEAR RETRY NO	RESTART RESET	RESTART/WIRE	RESTART/GAS	RESTART/ARC

40597	40596	40595	40594	40593	40592	40591	40590
SIN#472	SIN#471	SIN#470	SIN#469	SIN#468	SIN#467	SIN#466	SIN#465

40607	40606	40605	40604	40603	40602	40601	40600
SIN#480	SIN#479	SIN#478	SIN#477	SIN#476	SIN#475	SIN#474	SIN#473
							PROHIBIT SENSING

40617	40616	40615	40614	40613	40612	40611	40610
SIN#488	SIN#487	SIN#486	SIN#485	SIN#484	SIN#483	SIN#482	SIN#481

40627	40626	40625	40624	40623	40622	40621	40620
SIN#496	SIN#495	SIN#494	SIN#493	SIN#492	SIN#491	SIN#490	SIN#489

4 Specific I/O Signals

4.2 Specific Input Signals for Arc Welding

Device 2

40637	40636	40635	40634	40633	40632	40631	40630
SIN#504	SIN#503	SIN#502	SIN#501	SIN#500	SIN#499	SIN#498	SIN#497
ANTI-STICK REQUEST	RETRY RET REQUEST	RETRY REQUEST	NOZZLE CLEANED	TIP CHANGED	TIME MEASURE	WORKEND ANSWER	WORK START ANSWER

40647	40646	40645	40644	40643	40642	40641	40640
SIN#512	SIN#511	SIN#510	SIN#509	SIN#508	SIN#507	SIN#506	SIN#505
	CLEAR ANTI-STICK NO	CLEAR RESTART NO	CLEAR RETRY NO	RESTART RESET	RESTART/WIRE	RESTART/GAS	RESTART/ARC

40657	40656	40655	40654	40653	40652	40651	40650
SIN#520	SIN#519	SIN#518	SIN#517	SIN#516	SIN#515	SIN#514	SIN#513

40667	40666	40665	40664	40663	40662	40661	40660
SIN#528	SIN#527	SIN#526	SIN#525	SIN#524	SIN#523	SIN#522	SIN#521
							PROHIBIT SENSING

40677	40676	40675	40674	40673	40672	40671	40670
SIN#536	SIN#535	SIN#534	SIN#533	SIN#532	SIN#531	SIN#530	SIN#529

40687	40686	40685	40684	40683	40682	40681	40680
SIN#544	SIN#543	SIN#542	SIN#541	SIN#540	SIN#539	SIN#538	SIN#537

Device 3

40697	40696	40695	40694	40693	40692	40691	40690
SIN#552	SIN#551	SIN#550	SIN#549	SIN#548	SIN#547	SIN#546	SIN#545
ANTI-STICK REQUEST	RETRY RET REQUEST	RETRY REQUEST	NOZZLE CLEANED	TIP CHANGED	TIME MEASURE	WORK END ANSWER	WORK START ANSWER

40707	40706	40705	40704	40703	40702	40701	40700
SIN#560	SIN#559	SIN#558	SIN#557	SIN#556	SIN#555	SIN#554	SIN#553
	CLEAR ANTI-STICK NO	CLEAR RESTART NO	CLEAR RETRY NO	RESTART RESET	RESTART/WIRE	RESTART/GAS	RESTART/ARC

40717	40716	40715	40714	40713	40712	40711	40710
SIN#568	SIN#567	SIN#566	SIN#565	SIN#564	SIN#563	SIN#562	SIN#561

40727	40726	40725	40724	40723	40722	40721	40720
SIN#576	SIN#575	SIN#574	SIN#573	SIN#572	SIN#571	SIN#570	SIN#569
							PROHIBIT SENSING

40737	40736	40735	40734	40733	40732	40731	40730
SIN#584	SIN#583	SIN#582	SIN#581	SIN#580	SIN#579	SIN#578	SIN#577

40747	40746	40745	40744	40743	40742	40741	40740
SIN#592	SIN#591	SIN#590	SIN#589	SIN#588	SIN#587	SIN#586	SIN#585

4 Specific I/O Signals

4.2 Specific Input Signals for Arc Welding

Device 4

40757	40756	40755	40754	40753	40452	40751	40750
SIN#600	SIN#599	SIN#598	SIN#597	SIN#596	SIN#595	SIN#594	SIN#593
ANTI-STICK REQUEST	RETRY RET REQUEST	RETRY REQUEST	NOZZLE CLEANED	TIP CHANGED	TIME MEASURE	WORKEND ANSWER	WORK START ANSWER

40767	40766	40765	40764	40763	40762	40761	40760
SIN#608	SIN#607	SIN#606	SIN#605	SIN#604	SIN#603	SIN#602	SIN#601
	CLEAR ANTI-STICK NO	CLEAR RESTART NO	CLEAR RETRY NO	RESTART RESET	RESTART/WIRE	RESTART/GAS	RESTART/ARC

40777	40776	40775	40774	40773	40772	40771	40770
SIN#616	SIN#615	SIN#614	SIN#613	SIN#612	SIN#611	SIN#610	SIN#609

40787	40786	40785	40784	40783	40782	40781	40780
SIN#624	SIN#623	SIN#622	SIN#621	SIN#620	SIN#619	SIN#618	SIN#617
							PROHIBIT SENSING

40797	40796	40795	40794	40793	40792	40791	40790
SIN#632	SIN#631	SIN#630	SIN#629	SIN#628	SIN#627	SIN#626	SIN#625

40807	40806	40805	40804	40803	40802	40801	40800
SIN#640	SIN#639	SIN#638	SIN#637	SIN#636	SIN#635	SIN#634	SIN#633

4.3 Specific Input Signals for Handling

Device 1

40577	40576	40575	40574	40573	40572	40571	40570
SIN#456	SIN#455	SIN#454	SIN#453	SIN#452	SIN#451	SIN#450	SIN#449
					TIME MEASURE	WORKEND ANSWER	WORK START ANSWER

40587	40586	40585	40584	40583	40582	40581	40580
SIN#464	SIN#463	SIN#462	SIN#461	SIN#460	SIN#459	SIN#458	SIN#457
SENSOR INPUT 8	SENSOR INPUT 7	SENSOR INPUT 6	SENSOR INPUT 5	SENSOR INPUT 4	SENSOR INPUT 3	SENSOR INPUT 2	SENSOR INPUT 1

40597	40596	40595	40594	40593	40592	40591	40590
SIN#472	SIN#471	SIN#470	SIN#469	SIN#468	SIN#467	SIN#466	SIN#465

40607	40606	40605	40604	40603	40602	40601	40600
SIN#480	SIN#479	SIN#478	SIN#477	SIN#476	SIN#475	SIN#474	SIN#473

40617	40616	40615	40614	40613	40612	40611	40610
SIN#488	SIN#487	SIN#486	SIN#485	SIN#484	SIN#483	SIN#482	SIN#481

40627	40626	40625	40624	40623	40622	40621	40620
SIN#496	SIN#495	SIN#494	SIN#493	SIN#492	SIN#491	SIN#490	SIN#489

4 Specific I/O Signals

4.3 Specific Input Signals for Handling

Device 2

40637	40636	40635	40634	40633	40632	40631	40630
SIN#504	SIN#503	SIN#502	SIN#501	SIN#500	SIN#499	SIN#498	SIN#497
					TIME MEASURE	WORKEND ANSWER	WORK START ANSWER

40647	40646	40645	40644	40643	40642	40641	40640
SIN#512	SIN#511	SIN#510	SIN#509	SIN#508	SIN#507	SIN#506	SIN#505
SENSOR INPUT 8	SENSOR INPUT 7	SENSOR INPUT 6	SENSOR INPUT 5	SENSOR INPUT 4	SENSOR INPUT 3	SENSOR INPUT 2	SENSOR INPUT 1

40657	40656	40655	40654	40653	40652	40651	40650
SIN#520	SIN#519	SIN#518	SIN#517	SIN#516	SIN#515	SIN#514	SIN#513

40667	40666	40665	40664	40663	40662	40661	40660
SIN#528	SIN#527	SIN#526	SIN#525	SIN#524	SIN#523	SIN#522	SIN#521

40677	40676	40675	40674	40673	40672	40671	40670
SIN#536	SIN#535	SIN#534	SIN#533	SIN#532	SIN#531	SIN#530	SIN#529

40687	40686	40685	40684	40683	40682	40681	40680
SIN#544	SIN#543	SIN#542	SIN#541	SIN#540	SIN#539	SIN#538	SIN#537

Device 3

40697	40696	40695	40694	40693	40692	40691	40690
SIN#552	SIN#551	SIN#550	SIN#549	SIN#548	SIN#547	SIN#546	SIN#545
					TIME MEASURE	WORKEND ANSWER	WORK START ANSWER

40707	40706	40705	40704	40703	40702	40701	40700
SIN#560	SIN#559	SIN#558	SIN#557	SIN#556	SIN#555	SIN#554	SIN#553
SENSOR INPUT 8	SENSOR INPUT 7	SENSOR INPUT 6	SENSOR INPUT 5	SENSOR INPUT 4	SENSOR INPUT 3	SENSOR INPUT 2	SENSOR INPUT 1

40717	40716	40715	40714	40713	40712	40711	40710
SIN#568	SIN#567	SIN#566	SIN#565	SIN#564	SIN#563	SIN#562	SIN#561

40727	40726	40725	40754	40723	40722	40721	40720
SIN#576	SIN#575	SIN#574	SIN#573	SIN#572	SIN#571	SIN#570	SIN#569

40737	40736	40735	40734	40733	40732	40731	40730
SIN#584	SIN#583	SIN#582	SIN#581	SIN#580	SIN#579	SIN#578	SIN#577

40747	40746	40745	40744	40743	40742	40741	40740
SIN#592	SIN#591	SIN#590	SIN#589	SIN#588	SIN#587	SIN#586	SIN#585

4 Specific I/O Signals

4.3 Specific Input Signals for Handling

Device 4

40757	40756	40755	40754	40753	40752	40751	40750
SIN#600	SIN#599	SIN#598	SIN#597	SIN#596	SIN#595	SIN#594	SIN#593
					TIME MEASURE	WORK END ANSWER	WORK START ANSWER

40767	40766	40765	40764	40763	40762	40761	40760
SIN#608	SIN#607	SIN#606	SIN#605	SIN#604	SIN#603	SIN#602	SIN#601
SENSOR INPUT 8	SENSOR INPUT 7	SENSOR INPUT 6	SENSOR INPUT 5	SENSOR INPUT 4	SENSOR INPUT 3	SENSOR INPUT 2	SENSOR INPUT 1

40777	40776	40775	40774	40773	40772	40771	40770
SIN#616	SIN#615	SIN#614	SIN#613	SIN#612	SIN#611	SIN#610	SIN#609

40787	40786	40785	40784	40783	40782	40781	40780
SIN#624	SIN#623	SIN#622	SIN#621	SIN#620	SIN#619	SIN#618	SIN#617

40797	40796	40795	40794	40793	40792	40791	40790
SIN#632	SIN#631	SIN#630	SIN#629	SIN#628	SIN#627	SIN#626	SIN#625

40807	40806	40805	40804	40803	40802	40801	40800
SIN#640	SIN#639	SIN#638	SIN#637	SIN#636	SIN#635	SIN#634	SIN#633

4.4 Specific Input Signals for Spot Welding

Device 1

40577	40576	40575	40574	40573	40572	40571	40570
SIN#456	SIN#455	SIN#454	SIN#453	SIN#452	SIN#451	SIN#450	SIN#449
WELDING STOP WELDER 1		ELECTRODE EXCHG WELDER 1			TIME MEASURE	END WORK ANSWER	START WORK ANSWER

40587	40586	40585	40584	40583	41582	40581	40580
SIN#464	SIN#463	SIN#462	SIN#461	SIN#460	SIN#459	SIN#458	SIN#457
WELDING STOP WELDER 2		ELECTRODE EXCHG WELDER 2					

40597	40596	40595	40594	40593	40592	40591	40590
SIN#472	SIN#471	SIN#470	SIN#469	SIN#468	SIN#467	SIN#466	SIN#465
WELDING STOP WELDER 3		ELECTRODE EXCHG WELDER 3					

40607	40606	40605	40604	40603	40602	40601	40600
SIN#480	SIN#479	SIN#478	SIN#477	SIN#476	SIN#475	SIN#474	SIN#473
WELDING STOP WELDER 4		ELECTRODE EXCHG WELDER 4					

40617	40616	40615	40614	40613	40612	40611	40610
SIN#488	SIN#487	SIN#486	SIN#485	SIN#484	SIN#483	SIN#482	SIN#481

40627	40626	40625	40624	40623	40622	40621	40620
SIN#496	SIN#495	SIN#494	SIN#493	SIN#492	SIN#491	SIN#490	SIN#489

4 Specific I/O Signals

4.4 Specific Input Signals for Spot Welding

Device 2

40637	40636	40635	40634	40633	40632	40631	40630
SIN#504	SIN#503	SIN#502	SIN#501	SIN#500	SIN#499	SIN#498	SIN#497

40647	40646	40645	40644	40643	40642	40641	40640
SIN#512	SIN#511	SIN#510	SIN#509	SIN#508	SIN#507	SIN#506	SIN#505

40657	40656	40655	40654	40653	40652	40651	40650
SIN#520	SIN#519	SIN#518	SIN#517	SIN#516	SIN#515	SIN#514	SIN#513

40667	40666	40665	40664	40663	40662	40661	40660
SIN#528	SIN#527	SIN#526	SIN#525	SIN#524	SIN#523	SIN#522	SIN#521

40677	40676	40675	40674	40673	40672	40671	40670
SIN#536	SIN#535	SIN#534	SIN#533	SIN#532	SIN#531	SIN#530	SIN#529

40687	40686	40685	40684	40683	40682	40681	40680
SIN#544	SIN#543	SIN#542	SIN#541	SIN#540	SIN#539	SIN#538	SIN#537

Device 3

40697	40696	40695	40694	40693	40692	40691	40690
SIN#552	SIN#551	SIN#550	SIN#549	SIN#548	SIN#547	SIN#546	SIN#545

40707	40706	40705	40704	40703	40702	40701	40700
SIN#560	SIN#559	SIN#558	SIN#557	SIN#556	SIN#555	SIN#554	SIN#553

40717	40716	40715	40714	40713	40712	40711	40710
SIN#568	SIN#567	SIN#566	SIN#565	SIN#564	SIN#563	SIN#562	SIN#561

40727	40726	40725	40724	40723	40722	40721	40720
SIN#576	SIN#575	SIN#574	SIN#573	SIN#572	SIN#571	SIN#570	SIN#569

40737	40736	40735	40734	40733	40732	40731	40730
SIN#584	SIN#583	SIN#582	SIN#581	SIN#580	SIN#579	SIN#578	SIN#577

40747	40746	40745	40744	40743	40742	40741	40740
SIN#592	SIN#591	SIN#590	SIN#589	SIN#588	SIN#587	SIN#586	SIN#585

4 Specific I/O Signals

4.4 Specific Input Signals for Spot Welding

Device 4

40757	40756	40755	40754	40753	40752	40751	40750
SIN#600	SIN#599	SIN#598	SIN#597	SIN#596	SIN#595	SIN#594	SIN#593

40767	40766	40765	40764	40763	40762	40761	40760
SIN#608	SIN#607	SIN#606	SIN#605	SIN#604	SIN#603	SIN#602	SIN#601

40777	40776	40775	40774	40773	40772	40771	40770
SIN#616	SIN#615	SIN#614	SIN#613	SIN#612	SIN#611	SIN#610	SIN#609

40787	40786	40785	40784	40783	40782	40781	40780
SIN#624	SIN#623	SIN#622	SIN#621	SIN#620	SIN#619	SIN#618	SIN#617

40797	40796	40795	40794	40793	40792	40791	40790
SIN#632	SIN#631	SIN#630	SIN#629	SIN#628	SIN#627	SIN#626	SIN#625

40807	40806	40805	40804	40803	40802	40801	40800
SIN#640	SIN#639	SIN#638	SIN#637	SIN#636	SIN#635	SIN#634	SIN#633

4.5 Specific Input Signals for General-Purpose Applications

Device 1

40577	40576	40575	40574	40573	40572	40571	40570
SIN#456	SIN#455	SIN#454	SIN#453	SIN#452	SIN#451	SIN#450	SIN#449
					TIME MEASURE	WORKEND ANSWER	WORK START ANSWER

40587	40586	40585	40584	40583	41582	40581	40580
SIN#464	SIN#463	SIN#462	SIN#461	SIN#460	SIN#459	SIN#458	SIN#457

40597	40596	40595	40594	40593	40592	40591	40590
SIN#472	SIN#471	SIN#470	SIN#469	SIN#468	SIN#467	SIN#466	SIN#465

40607	40606	40605	40604	40603	40602	40601	40600
SIN#480	SIN#479	SIN#478	SIN#477	SIN#476	SIN#475	SIN#474	SIN#473

40617	40616	40615	40614	40613	40612	40611	40610
SIN#488	SIN#487	SIN#486	SIN#485	SIN#484	SIN#483	SIN#482	SIN#481

40627	40626	40625	40624	40623	40622	40621	40620
SIN#496	SIN#495	SIN#494	SIN#493	SIN#492	SIN#491	SIN#490	SIN#489

4 Specific I/O Signals

4.5 Specific Input Signals for General-Purpose Applications

Device 2

40637	40636	40635	40634	40633	40632	40631	40630
SIN#504	SIN#503	SIN#502	SIN#501	SIN#500	SIN#499	SIN#498	SIN#497
					TIME MEASURE	WORKEND ANSWER	WORK START ANSWER

40647	40646	40645	40644	40643	40642	40641	40640
SIN#512	SIN#511	SIN#510	SIN#509	SIN#508	SIN#507	SIN#506	SIN#505

40657	40656	40655	40654	40653	40652	40651	40650
SIN#520	SIN#519	SIN#518	SIN#517	SIN#516	SIN#515	SIN#514	SIN#513

40667	40666	40665	40664	40663	40662	40661	40660
SIN#528	SIN#527	SIN#526	SIN#525	SIN#524	SIN#523	SIN#522	SIN#521

40677	40676	40675	40674	40673	40672	40671	40670
SIN#536	SIN#535	SIN#534	SIN#533	SIN#532	SIN#531	SIN#530	SIN#529

40687	40686	40685	40684	40683	40682	40681	40680
SIN#544	SIN#543	SIN#542	SIN#541	SIN#540	SIN#539	SIN#538	SIN#537

4 Specific I/O Signals
4.5 Specific Input Signals for General-Purpose Applications

Device 3

40697	40696	40695	40694	40693	40692	40691	40690
SIN#552	SIN#551	SIN#550	SIN#549	SIN#548	SIN#547	SIN#546	SIN#545
					TIME MEASURE	WORKEND ANSWER	WORK START ANSWER

40707	40706	40705	40704	40703	40702	40701	40700
SIN#560	SIN#559	SIN#558	SIN#557	SIN#556	SIN#555	SIN#554	SIN#553

40717	40716	40715	40714	40713	40712	40711	40710
SIN#568	SIN#567	SIN#566	SIN#565	SIN#564	SIN#563	SIN#562	SIN#561

40727	40726	40725	40724	40723	40722	40721	40720
SIN#576	SIN#575	SIN#574	SIN#573	SIN#572	SIN#571	SIN#570	SIN#569

40737	40736	40735	40734	40733	40732	40731	40730
SIN#584	SIN#583	SIN#582	SIN#581	SIN#580	SIN#579	SIN#578	SIN#577

40747	40746	40745	40744	40743	40742	40741	40740
SIN#592	SIN#591	SIN#590	SIN#589	SIN#588	SIN#587	SIN#586	SIN#585

4 Specific I/O Signals

4.5 Specific Input Signals for General-Purpose Applications

Device 4

40757	40756	40755	40754	40753	40752	40751	40750
SIN#600	SIN#599	SIN#598	SIN#597	SIN#596	SIN#595	SIN#594	SIN#593
					TIME MEASURE	WORKEND ANSWER	WORK START ANSWER

40767	40766	40765	40764	40763	40762	40761	40760
SIN#608	SIN#607	SIN#606	SIN#605	SIN#604	SIN#603	SIN#602	SIN#601

40777	40776	40775	40774	40773	40772	40771	40770
SIN#616	SIN#615	SIN#614	SIN#613	SIN#612	SIN#611	SIN#610	SIN#609

40787	40786	40785	40784	40783	40782	40781	40780
SIN#624	SIN#623	SIN#622	SIN#621	SIN#620	SIN#619	SIN#618	SIN#617

40797	40796	40795	40794	40793	40792	40791	40790
SIN#632	SIN#631	SIN#630	SIN#629	SIN#628	SIN#627	SIN#626	SIN#625

40807	40806	40805	40804	40803	40802	40801	40800
SIN#640	SIN#639	SIN#638	SIN#637	SIN#636	SIN#635	SIN#634	SIN#633

4.6 Specific Input Signals: Explanation

The following symbols are used in the explanation to represent the signal condition.



The signal takes effect while it is in ON state.



The rising edge is detected as the signal.

4.6.1 Alarm and Message Display

Various information items about the application can be displayed as messages on the programming pendant screen of the NX100. This section explains how to select already created messages. For registration, refer to “Registration of I/O Alarms and Messages”.

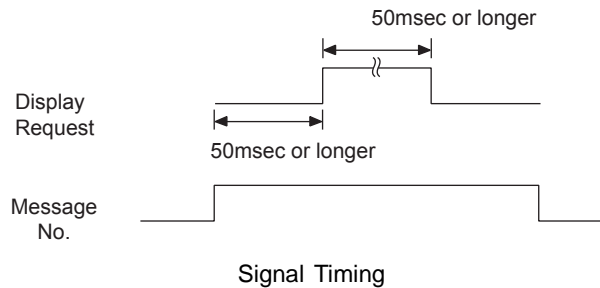

Display request signal is a state signal, which continues to update the display while the signal is ON.

■ 40010: SYSTEM ALARM REQUEST



When this signal is ON, a system alarm occurs and the manipulator stops. At the same time, an alarm message corresponding to the alarm code of the specific inputs (40130 to 40135) appears on the programming pendant screen.

40130 to 40135: System alarm No. (binary)

Up to 64 system alarms can be specified. Assign messages by coding decimals from 0 to 63 into binaries..

No.	Setting Value 0: OFF 1: ON					
	40135	40134	40133	40132	40131	40130
0	0	0	0	0	0	0
1	0	0	0	0	0	1
2	0	0	0	0	1	0
3	0	0	0	0	1	1
:	:	:	:	:	:	:
63	1	1	1	1	1	1

4 Specific I/O Signals

4.6 Specific Input Signals: Explanation

■ 40011: SYSTEM MESSAGE REQUEST



When this signal is on, the message of the corresponding message code of specific inputs (40150 to 40155) appears on the programming pendant screen. Manipulator operation will not be affected even if the message is displayed.

40150 to 40155: System Message No. (Binary)

Up to 64 system messages can be specified. Assign messages by coding decimals from 0 to 63 into binaries.

No.	Setting Value 0: OFF 1: ON					
	40155	40154	40153	40152	40151	40150
0	0	0	0	0	0	0
1	0	0	0	0	0	1
2	0	0	0	0	1	0
3	0	0	0	0	1	1
:	:	:	:	:	:	:
63	1	1	1	1	1	1

■ 40012: USER ALARM REQUEST



When this signal is on, a user alarm occurs and the manipulator stops. At the same time, an alarm message corresponding to the alarm code of the specific input (40140 to 40145) appears on the programming pendant screen.

40140 to 40145: User Alarm No.

Up to 64 system alarms can be specified. Assign messages by coding decimals from 0 to 63 into binaries.

No.	Setting Value 0: OFF 1: ON					
	40145	40144	40143	40142	40141	40140
0	0	0	0	0	0	0
1	0	0	0	0	0	1
2	0	0	0	0	1	0
3	0	0	0	0	1	1
:	:	:	:	:	:	:
63	1	1	1	1	1	1

■ 40013: USER MESSAGE REQUEST



When this signal is on, the message of the corresponding message code of specific inputs (40160 to 40165) appears on the programming pendant screen. Manipulator operation will not be affected even if the message is displayed.

40160 to 40165: User Message No. (Binary)

Up to 64 user messages can be specified. Assign messages by coding decimals from 0 to 63 into binaries.

No.	Setting Value 0: OFF 1: ON					
	40165	40164	40163	40162	40161	40160
0	0	0	0	0	0	0
1	0	0	0	0	0	1
2	0	0	0	0	1	0
3	0	0	0	0	1	1
:	:	:	:	:	:	:
63	1	1	1	1	1	1

■ 40014: ALARM RESET



This signal clears alarms or errors when there is a minor failure, system alarm, user alarm, or user error. Use this signal when desiring to reset an alarm or error from the outside.

<Example>

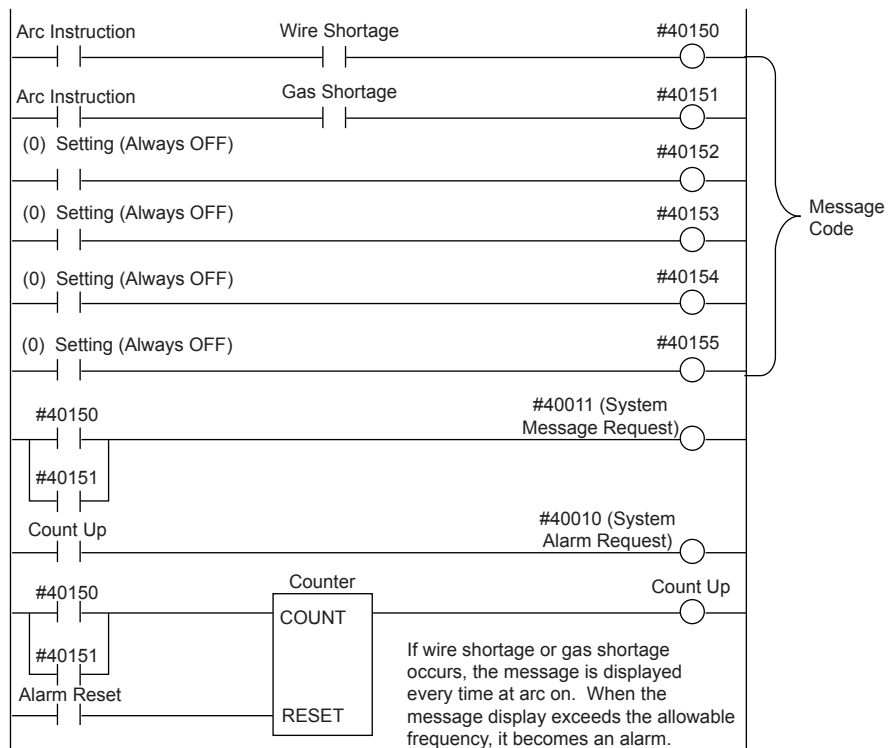

4 Specific I/O Signals

4.6 Specific Input Signals: Explanation

4.6.2 Selecting Mode/Cycle and Calling Master Job

■ 40030: MASTER JOB CALLING



This signal resets the operating sequence. When the signal is on, the heading of the master job (Line: 0) will be called up as an execution job. This can be used for executing system initialization automatically when the power is turned on .

However, it is invalid in the following cases:

- While the manipulator is operating (job is executing)
- While the servo power is ON in the teach mode.
- "MASTER CALLING UP PROHIBIT" is shown on the operating condition window.

■ 40040, 40041: Selection of Modes



These signals have the same function as the mode key on the programming pendant. Use these signals when desiring to change mode specifications from the outside.

If two or more modes are specified at the same time, TEACH MODE has a priority over another.

They are invalid when "EXT. MODE SWITCH PROHIBIT" is shown on the operating condition window, and when the mode key on the programming pendant is set to "TEACH" or "PLAY". (The mode specified with the mode key prevails.)

■ 40042, 40056, 40057: Selection of Operating Modes



40042 CMD REMOTE SELECT

This signal selects a command remote function such as transmission. When the system transmission function (optional) is valid, "CMD REMOTE SETTING" (50056) signal goes on and the NX100 gets ready for transmission with the master computer.

40056 PROHIBIT PP OPERATION

When this signal is on, cycle, start and servo on master job call from the programming pendant are prohibited. However, this prohibition is released by setting the PP Operation at Remote Mode parameter (S2C182).

40057 PROHIBIT IO

When this signal is on, the following operation from external input is prohibited.

- Selection of Cycle (40050 to 40052)
- Calling Up Master Job (40030)
- External Servo On (40045)
- External Start (40044)

Operation Mode Processing Standard Ladders

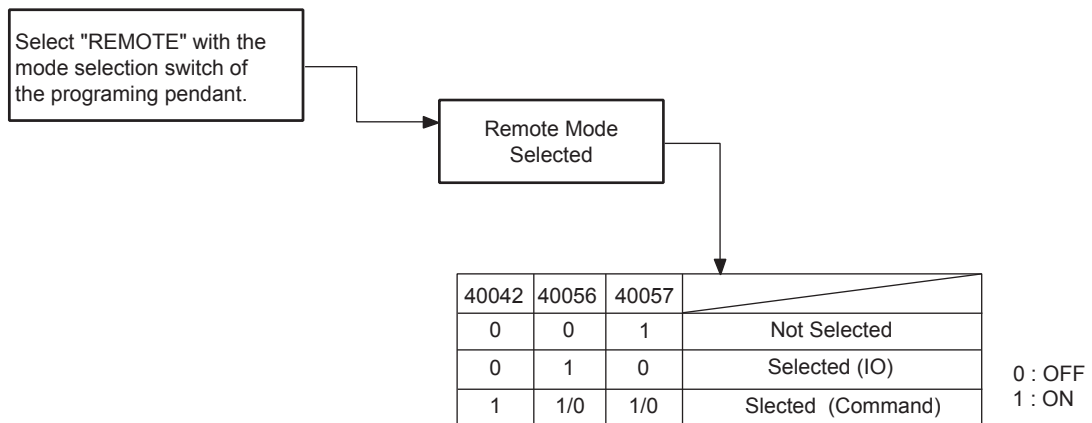

- For remote function selection, refer to the “7 Pseudo Input Signals”.
- Transmission function is an optional function.

■ 40050 to 40052: Selection of Cycles



Use the signals when desiring to change cycle specifications from the outside. These can also be used when desiring to fix a specified cycle.

If two or more cycles are specified at the same time, or it is operated with the programming pendant at the same time, the cycle will not change.

These are invalid when “EXT. MODE SWITCH PROHIBIT” is shown on the operating condition window.

4.6.3 Start and Stop Signals

■ 40044: EXTERNAL START



This signal has the same function as the “START” button on the programming pendant.

Automatic operation starts in accordance with cycle specifications. When this signal is accepted, “OPERATING” (50070) and “PERMISSIBLE WORK OPERATING” (50264) signals will be turned on. The signal can be used when starting from a panel other than the NX100 programming pendant such as an external operator’s panel. Since only one place on the programming pendant or external input can be specified as the “STARTING” base from the stand point of safety, specify “EXTERNAL START PROHIBIT” on the operating condition window.

This signal is invalid under the following conditions:

- Servo power supply is turned off.
- Remote mode is not selected.
- “EXTERNAL START PROHIBIT” is on the operating condition window.
- Manipulator is still operating. [When “OPERATING” (50070) signal is on].
- When “HOLDING” (50071) signal is on.
- “EXTERNAL HOLD” (40067) signal is on.

■ 40045: EXTERNAL SERVO ON



This signal turns on the servo power. Use the signal when turning on the servo power from the outside.

To use this signal, connect the external servo on signal (EXSVON) on the specific input terminal block to +24V (29 - 30). For details, see “10 I/O Except Concurrent I/O”. For safe use

4 Specific I/O Signals

4.6 Specific Input Signals: Explanation

of the robot, it is recommended to use the above external servo on input on the I/O power on unit without intervention of the ladder.

This signal is invalid when “EXT. MODE SWITCH PROHIBIT” is shown on the operating condition window.

■ 40054, 40065, 40066: EXTERNAL SERVO OFF



When these signals are on, the servo power supply is cut off and the manipulator stops. Use the signals when desiring to cut off the servo power supply from the outside or by ladder conditions for reasons other than the emergency stop. While these signals are on, the servo power remains off even if the servo on reference (from programming pendant, or outside) is turned on.

40065: EXTERNAL SERVO OFF 1 (Deceleration stop)

40066: EXTERNAL SERVO OFF 2 (Emergency stop category 0)

40054: EXTERNAL SERVO OFF 3 (Emergency stop category 1)

■ 40067: EXTERNAL HOLD



This signal has the same function as the “HOLD” button on the programming pendant. Use the signal when instructing “HOLD” from a location other than the programming pendant. While the signal is on, the “HOLD” lamp on the programming pendant is blinking and the “HOLDING” (50071) signal goes ON.

4.6.4 Operating Instructions

■ 40016: In-Guard Safe Operating Instruction



When this signal is on, the playback operating speed is limited by in-guard safe operation speed. If approaching the manipulator during operation for unavoidable reasons, the operating speed can be limited by turning the signal on. It will therefore be convenient to interlink the signal with the safety guardrail or safety mat.



This signal is only to limit speed. Since the manipulator operates as taught, prepare the “EMERGENCY STOP” button so that it can be pressed at any time in the event of an emergency when one approaches the robot.

■ 40046: Check Operation



This signal is not a start instruction. When the signal is on, the work instruction in the job is not executed. Use the signal to check the taught steps and motions. This signal is invalid when “CHECK/ MACHINE LOCK PROHIBIT” on the operating condition window is on.

■ 40047: PROHIBIT WEAVING



When this signal is on, weaving in the job are not executed. Use the signal to check the taught steps and motions with weaving off.

■ 40053: PLAY MODE ENABLE



This signal is used as an alternative for the Play Mode Enable switch in the Play Mode Enable function.

Enabling this signal after switching the mode to "PLAY" allows operation of the programming pendant in the Play Mode.

■ 40060: MACHINE LOCK



When this signal is on, the machine lock mode is selected.

■ 40061: INVALID SHOCK DETECTION



When this signal is on, the shock detection function is invalid.

■ 40063: OVERRUN RELEASE REQUEST



When this signal is on, the overrun status is released.

This signal has the same function as the overrun release operation in the overrun and shock sensor release window; however, setting the value for S2C453 allows whether to enable the function depending on the window displayed on the programming pendant screen.

0: Standard (The function is enabled when any window is displayed)

1: Enabled with interface panel (The function is enabled only when interface panel is displayed)

■ 40064: EDIT LOCK



When this signal is on, the job editing operation is prohibited.

■ 40070 to 40073: 1-Step Back Operating Instruction



When these signals are on at start up, the manipulator moves to one step before the displayed step at low speed and stops there disregarding the cycle. These can be used for performing the operation one step before since some operations are difficult to be executed.

For a system with one manipulator, use signal No. 40070.

■ 40090 to 40093: SEQUENCE WAIT



The manipulator pauses while this signal is on. Although it is functionally the same as "HOLD", it differs in the following ways:

1. When these signals are turned on while the manipulator is operating, the manipulator pauses temporarily, but it is still in an operating state. If these signals are turned on during an instruction other than a moving instruction (MOV), the instruction is continued. The "START" lamp remains lit and the "OPERATING" signal remains ON. If these signals are turned on while the manipulator is operating at high speed, the manipulator reduces its speed and stops.
2. The status of these signals are controlled. Motion of the manipulator is automatically

4 Specific I/O Signals

4.6 Specific Input Signals: Explanation

resumed when changing from on to off.

For a system with one manipulator, use signal No. 40090.

<Example 1>

The following is an example of using the signal to check S-Axis/ Cube Interference.

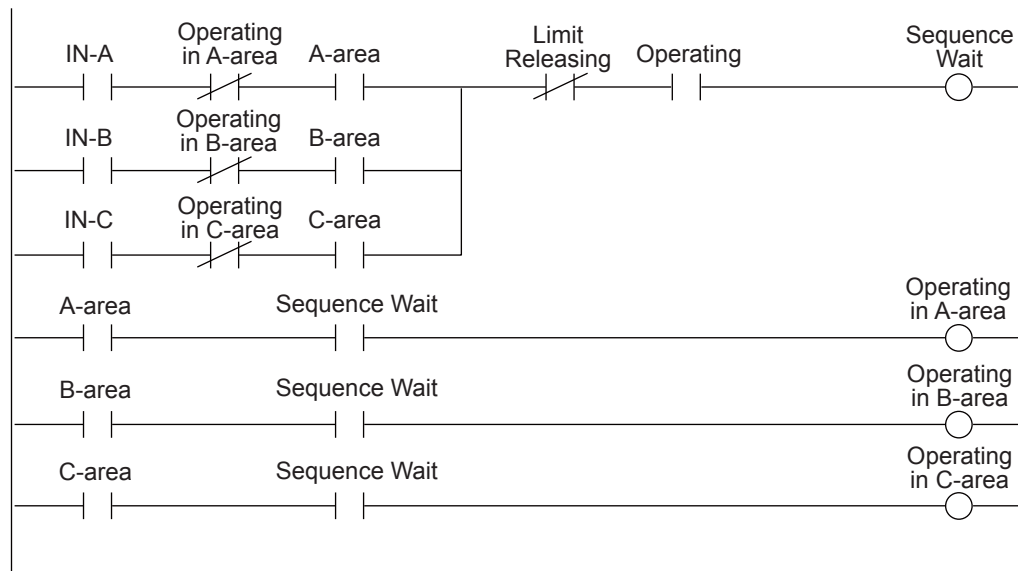

Explanation of ladder

Meaning of above terms	
A, B, C:	Area Name e.g. S-Axis (right), Cube 1, etc
IN-A, IN-B, IN-C:	Status of the combined equipment input externally
Area A, Area B, Area C:	Individual status signals The signals indicate whether the manipulator is in the area.
Operating in A-area, Operating in B-area, Operating in C-area:	ON when operating in the area The signals are assigned to the combined equipment.

If the signal "Area A", "Area B", or "Area C" is turned on while the combined equipment is outside the area, the signal "Operating in A-area", "Operating in B-area", or "Operating in C-area" is turned ON and the operation continues.

If the combined equipment is in the area first, the SEQUENCE WAIT signal goes ON and robot operation is stopped until the combined equipment leaves the area. When the combined equipment leaves the area, the SEQUENCE WAIT signal goes off and manipulator operation resumes.

<Example 2>

The following is an example of using the signal to detect wire sticking in arc welding.

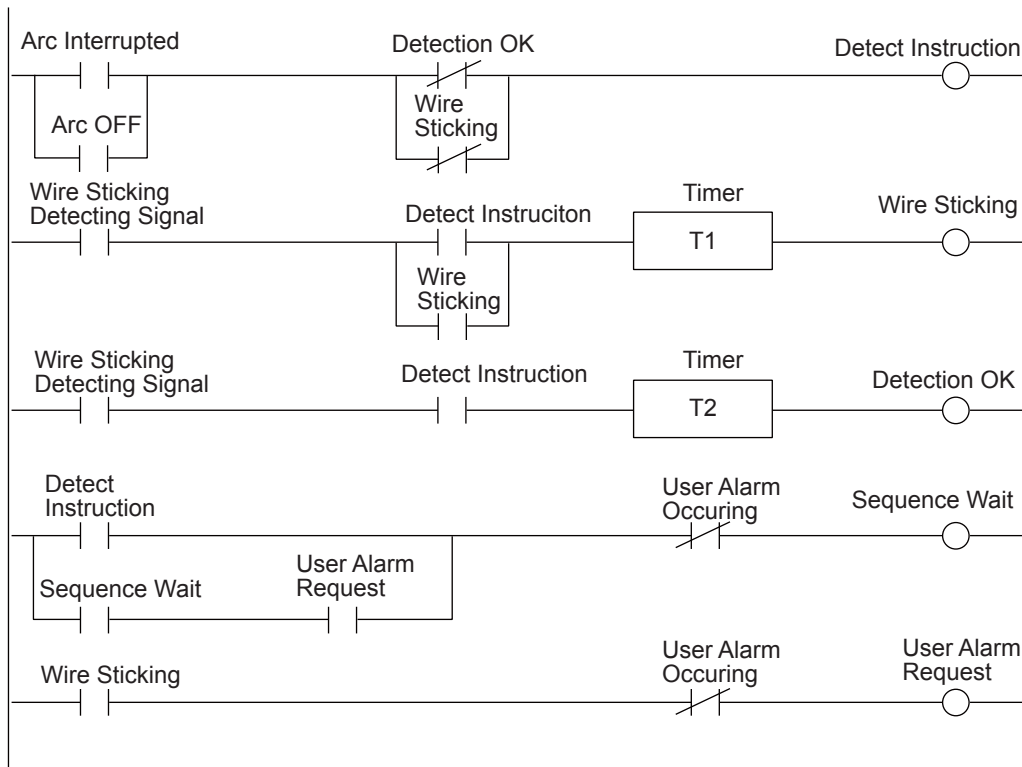

Explanation of ladder

Monitor the state of welding when an ARC OFF instruction is issued, or if the arc is interrupted while the instruction is being issued. When detecting wire sticking, the SEQUENCE WAIT REQUEST goes ON and the manipulator pauses.

Normal

Detection OK will be determined when the OFF state of the wire sticking detection signal continues for the prescribed time. SEQUENCE WAIT will then be released and the manipulator will resume operation.

Abnormal

Welding is determined abnormal if the ON state of the wire sticking detecting signal continues longer than the prescribed time.

I/O alarm will occur if welding is abnormal, and SEQUENCE WAIT will then be cleared.

■ 40110 to 40113: Work Home Position Return Request



The manipulator moves to the work home position at the speed of parameter SICxG056 at joint operation by starting up these signals in the play mode.

During returning to the home position, the "START" lamp is lit ("during start" is entered) and the message "Operation Origin Returning" is displayed on the programming pendant screen.

Do not use these signals unless interlocking to check that the manipulator is at a position from which it can return to the home position.

For a system with one manipulator, use signal No. 40110.

4 Specific I/O Signals

4.6 Specific Input Signals: Explanation

■ 40337: PP Buzzer



When this signal is on, the buzzer of programming pendant sounds.

4.6.5 Independent Control Signals (Optional)

■ 40021 to 40027: SUB 1, 2, 3, 4, 5, 6, 7 ALARM REQUEST



These signals are used to stop the specified sub task with an alarm when system section alarm request (40010) or user section alarm request (40012) is issued.

Input the alarm request (40010 or 40012) after setting the conditions of individual requirements.

Setting Value 0: OFF 1: ON							Meaning
40027	40026	40025	40024	40023	40022	40021	
0	0	0	0	0	0	0	Stops all tasks
0	0	0	0	0	0	1	Stops sub task 1
:	:	:	:	:	:	:	:
1	1	1	1	1	1	1	Stops sub task 1, 2, 3, 4, 5, 6, 7

■ 40031 to 40037: SUB1, 2, 3, 4, 5, 6, 7 MASTER CALL



Operation sequence is reset. When these signals are turned on, the head of the master job in sub take 1, 2, 3, 4, 5, 6 or 7 is called up as an execution job.

These signals are invalid in any of the following cases:

- The manipulator is operating (during job execution).
- While the servo power is on in the teach mode.
- “MASTER CALLING UP PROHIBIT” is shown on the operating condition window.
- Master job is not registered.

■ 40170 to 40177: SUB 1, 2, 3, 4, 5, 6, 7, and MASTER START REQUEST



When the signals are turned on, the robot starts its operation automatically by each sub task 1, 2, 3, 4, 5, 6, 7, and the master job individually. When the signals are accepted, the signals "RUN", 50320 to 50327 are turned on. The signals can be used when starting from a panel such as an external operator's panel other than the NX100 programming pendant. Specify the condition on the operating condition window.

These signals are invalid in any of the following cases: ì

- The servo power is not turned on.
- The PLAY mode is not set.
- The "EXTERNAL START PROHIBIT" is shown on the operating condition window.
- The corresponding signal "RUN" is on. That is the robot is operating.
- The signal "HOLDING" is on.
- The signal "EXTERNAL HOLD" is on
- The corresponding signal "HOLDING" is on.

■ 40180 to 40187: SUB 1, 2, 3, 4, 5, 6, 7 HOLD REQUEST



When these signals are turned on, the manipulator, which is running individually in accordance with each sub task 1, 2, 3, 4, 5, 6, 7 and the master job, pauses. The corresponding signal "HOLDING" (50330 to 50337) is turned on when this signal is ON.

4.6.6 Signals for Arc Welding

Signals from 40570 to 40807 are classified into four blocks and assigned to input signals that have different meanings depending on the application. Most of these inputs are used by the system and they cannot be used from the outside of the NX100. This section explains exceptional signals available for using from the outside.

■ 40570, 40630, 40690, 40750: WORK START RESPONSE



The "WORK START RESPONSE" signals are used for response to the "WORK START" instructions (50770, 50830, 50890, 50950).

■ 40571, 40631, 40691, 40751: WORK END RESPONSE



The "WORK END RESPONSE" signals are used for response to the "WORK END" instructions (50771, 50831, 50891, 50951).

■ 40572, 40632, 40692, 40752: WORK TIME MEASURE



The time during which these signals are on is measured as the operating time. The operating time can be checked on the system monitoring time window.

For a system with one application, use signal No. 40572.

4 Specific I/O Signals

4.6 Specific Input Signals: Explanation

■ 40573, 40633, 40693, 40753: TIP REPLACEMENT COMPLETED



When these signals are on, tip replacement time is reset and the “TIP REPLACEMENT REQUEST” (50773, 50833, 50893, or 50953) signal goes off.

For a system with one application, use signal No. 40573.

■ 40574, 40634, 40694, 40754: NOZZLE CLEANING COMPLETED



When these signals are on, nozzle cleaning time is reset and the “NOZZLE CLEANING REQUEST” (50774, 50834, 50894, or 50954) signal goes off.

For a system with one application, use signal No. 40574.

■ 40575, 40635, 40695, 40755: RETRY REQUEST



■ 40576, 40636, 40696, 40756: RETRY RETURN REQUEST



The “WORK START RESPONSE” signal is used for response to the “WORK START INSTRUCTION” (50770, 50830, 50890, or 50950) signal. When the “RETRY REQUEST” signal is used simultaneously, retry operation is performed; when the “RETRY RETURN REQUEST” signal is used simultaneously, retry return operation is performed. By responding individually, the work start instruction is completed.

For a system with one application, use signal No. 40570, 40575, or 40576.

■40577, 40637, 40697, 40757: AUTOMATIC ANTI-STICKING REQUEST



The “WORK END RESPONSE” signal is used for response to the “WORK START INSTRUCTION” (50771, 50831, 50891, or 50951) signal. When the “AUTOMATIC ANTI-STICKING REQUEST” signal is used simultaneously, anti-sticking operation is performed. By responding individually, the work start instruction is completed.

For a system with one application, use signal No. 40571 or 40577.

■40580, 40640, 40700, 40760: RESTART REQUEST (ARC SHORTAGE)



■ 40581, 40641, 40701, 40761: RESTART REQUEST (GAS SHORTAGE)



■ **40582, 40642, 40702, 40762:
RESTART REQUEST (WIRE SHORTAGE)**



When these signals are on, restart operations are requested. The restart operation differs from each restart mode.

For a system with one application, use signal No. 40580, 40581, or 40582.



Multiple requests cannot be made.
The priority order of requests is arc shortage → gas shortage → wire shortage.

■ **40583, 40643, 40703, 40763: RESTART RESET PROCESS**



When these signals are on, the restart process is released. When “manual intervention method” is selected as a restart method, use these signals to release the restart process after manual intervention. For the initial value, OT#1022 (user open signal) is connected.

For a system with one application, use signal No. 40583.

■ **40584, 40644, 40704, 40764: RETRY TIMES CLEAR**



When these signals are on, the number of retries is cleared.

For a system with one application, use signal No. 40584.

■ **40585, 40645, 40705, 40766:
ARC SHORTAGE RESTART TIMES CLEAR**



When these signals are on, the number of arc shortage restarts is cleared.

For a system with one application, use signal No. 40585.

■ **40586, 40646, 40706, 40766:
AUTOMATIC ANTI-STICKING TIMES CLEAR**



When these signals are on, the number of automatic anti-stickings is cleared.

For a system with one application, use signal No. 40586.

■ **40600, 40660, 40720, 40780: SENSING PROHIBIT**



When these signals are on, sensing is not performed in the started job. Use the signals to check the taught steps and motions with the sensing function off.

4 Specific I/O Signals

4.6 Specific Input Signals: Explanation

4.6.7 Signals for Handling

Signals from 40570 to 40807 are classified into four blocks and assigned to input signals that have each different meanings depending on the application. As most of these input signals are used for the system, they cannot be used from outside of the NX100.

This section explains exceptional signals that are available for external use.

■ 40570, 40630, 40690, 40750: WORK START RESPONSE



These signals are used for response to “WORK START INSTRUCTION” (50770, 50830, 50890, or 50950) signal. The work start instruction is completed by the response.

For a system with one application, use signal No. 40570.

■ 40571, 40631, 40691, 40751: WORK END RESPONSE



These signals are used for response to “WORK END INSTRUCTION” (50771, 50831, 50891, or 50951) signal. The work end instruction is completed by the response.

For a system with one application, use signal No. 40571.

■ 40572, 40632, 40692, 40752: WORK TIME MEASURE



The time during which these signals are on is measured as the operating time. The operating time can be checked on the system monitoring time window.

For a system with one application, use signal No. 40572.

■ 40580 to 40587, 40640 to 40647, 40700 to 40707, 40760 to 40767: SENSOR INPUT



These signals are specific inputs which allow to grasp the signal status using the specific instruction “HSEN” for handling. When using the “HSEN” instruction, connect the sensor to the specific input of the NIO01 board which is connected to these signals.

For a system with one manipulator, use signal Nos. 40580 to 40587.

4.6.8 Signals for Spot Welding

Signals from 40570 to 40807 are classified into four blocks and are assigned to input signals according to its welding application. As most of these input signals are used for the system, they cannot be used from outside of the NX100.

This section explains exceptional signals that are available for external use.

■ 40572, 40632, 40692, 40752: WORK TIME MEASURE



The time during which these signals are ON is measured as the operating time. The operating time can be checked on the system monitoring time window.

For a system with one application, use signal No. 40582.

■ 40575, 40585, 40595, 40605: ELECTRODE REPLACEMENT



When a SVGUNCL instruction is executing with this signal on, the electrode wear amount absolute value is compared to the threshold value. The signal outputs the wear detection normal in the case that the absolute value is less than the threshold value after the replacement.

■ 40587, 40597, 40607, 40617: WELDING STOP



This signal stops execution of the welding instruction. While this signal is ON, the robot playbacks disregarding the spot welding instruction. Use this signal when errors in welders or guns occur and the robot should return to the working home position, etc.

For a system with one application, use signal No. 4177.

4 Specific I/O Signals

4.6 Specific Input Signals: Explanation

4.6.9 Signals for General-Purpose Applications

Signals from 40570 to 40807 are classified into four blocks and assigned to input signals that have each different meanings depending on the application. As most of these input signals are used for the system, they cannot be used from the outside of the NX100.

This section explains exceptional signals that are available for external use.

■ 40570, 40630, 40690, 40750: WORK START RESPONSE



These signals are used for response to "WORK START INSTRUCTION" (50770, 50830, 50890, or 50950) signal. The work start instruction is completed by the response.

For a system with one application, use signal No. 40570.

■ 40571, 40631, 40691, 40751: WORK END RESPONSE



These signals are used for response to "WORK END INSTRUCTION" (50771, 50831, 50891, or 50951) signal.

For a system with one application, use signal No. 40571.

■ 40572, 40632, 40692, 40752: WORK TIME MEASURE



The time during which these signals are on is measured as the operating time. This operating time can be checked on the system monitoring time window.

For a system with one application, use signal No. 40572.

4.7 Specific Output Signals for All Applications

50017	50016	50015	50014	50013	50012	50011	50010
SOUT#008	SOUT#007	SOUT#006	SOUT#005	SOUT#004	SOUT#003	SOUT#002	SOUT#001
COOLING FAN ERROR	ENCODER BATTERY WEAK	MEM BATTERY WEAK	ERROR OCCUR	USER ALARM OCCUR	SYSTEM ALARM OCCUR	MINOR ALARM OCCUR	MAJOR ALARM OCCUR

50027	50026	50025	50024	50023	50022	50021	50020
SOUT#016	SOUT#015	SOUT#014	SOUT#013	SOUT#012	SOUT#011	SOUT#010	SOUT#009
TOP SUB MASTER JOB 7	TOP SUB MASTER JOB 6	TOP SUB MASTER JOB 5	TOP SUB MASTER JOB 4	TOP SUB MASTER JOB 3	TOP SUB MASTER JOB 2	TOP SUB MASTER JOB 1	TOP MASTER JOB

50037	50036	50035	50034	50033	50032	50031	50030
SOUT#024	SOUT#023	SOUT#022	SOUT#021	SOUT#020	SOUT#019	SOUT#018	SOUT#017
SUB MASTER 7 HELD	SUB MASTER 6 HELD	SUB MASTER 5 HELD	SUB MASTER 4 HELD	SUB MASTER 3 HELD	SUB MASTER 2 HELD	SUB MASTER 1 HELD	

50047	50046	50045	50044	50043	50042	50041	50040
SOUT#032	SOUT#031	SOUT#030	SOUT#029	SOUT#028	SOUT#027	SOUT#026	SOUT#025
SUB MASTER 7 ALARM OCCUR	SUB MASTER 6 ALARM OCCUR	SUB MASTER 5 ALARM OCCUR	SUB MASTER 4 ALARM OCCUR	SUB MASTER 3 ALARM OCCUR	SUB MASTER 2 ALARM OCCUR	SUB MASTER 1 ALARM OCCUR	

50057	50056	50055	50054	50053	50052	50051	50050
SOUT#040	SOUT#039	SOUT#038	SOUT#037	SOUT#036	SOUT#035	SOUT#034	SOUT#033
	CMD REMOTE SET		PLAY MODE SET	TEACH MODE SET	CONT CYCLE SET	1-CYCLE SET	STEP CYCLE SET

50067	50066	50065	50064	50063	50062	50061	50060
SOUT#048	SOUT#047	SOUT#046	SOUT#045	SOUT#044	SOUT#043	SOUT#042	SOUT#041
RUNNING AT FULL-SPEED	POSITION CHECKED	APL KEY	CHECK RUN SET	SOFT LIMIT SET RELEASE	MACHINE LOCK SET	DRY RUN SET	SAFETY SPEED SET

50077	50076	50075	50074	50073	50072	50071	50070
SOUT#056	SOUT#055	SOUT#054	SOUT#053	SOUT#052	SOUT#051	SOUT#050	SOUT#049
OT RELEASE	JOG OPERATION INFORM	JOB EDIT INFORM	I/O SIMULATED	SERVO ON		HOLDING (HOLD LAMP)	RUNNING

4 Specific I/O Signals

4.7 Specific Output Signals for All Applications

50087	50086	50085	50084	50083	50082	50081	50080
SOUT#064	SOUT#063	SOUT#062	SOUT#061	SOUT#060	SOUT#059	SOUT#058	SOUT#057
CUBE INTERFERENCE							
8	7	6	5	4	3	2	1

50097	50096	50095	50094	50093	50092	50091	50090
SOUT#072	SOUT#071	SOUT#070	SOUT#069	SOUT#068	SOUT#067	SOUT#066	SOUT#065
CUBE INTERFERENCE							
16	15	14	13	12	11	10	9

50107	50106	50105	50104	50103	50102	50101	50100
SOUT#080	SOUT#079	SOUT#078	SOUT#077	SOUT#076	SOUT#075	SOUT#074	SOUT#073
CUBE INTERFERENCE							
24	23	22	21	20	19	18	17

50117	50116	50115	50114	50113	50112	50111	50110
SOUT#088	SOUT#087	SOUT#086	SOUT#085	SOUT#084	SOUT#083	SOUT#082	SOUT#081
CUBE INTERFERENCE							
32	31	30	29	28	27	26	25

50127	50126	50125	50124	50123	50122	50121	50120
SOUT#096	SOUT#095	SOUT#094	SOUT#093	SOUT#092	SOUT#091	SOUT#090	SOUT#089

50137	50136	50135	50134	50133	50132	50131	50130
SOUT#104	SOUT#103	SOUT#102	SOUT#101	SOUT#100	SOUT#099	SOUT#098	SOUT#097

50147	50146	50145	50144	50143	50142	50141	50140
SOUT#112	SOUT#111	SOUT#110	SOUT#109	SOUT#108	SOUT#107	SOUT#106	SOUT#105
SPHERE INPUT	SPHERE INPUT	CRD WORKING R1, R2	SPHERE INTRF R1, R2	CRD WORKING R4, R1	SPHERE INTRF R4, R1	S-AXIS INTRF	
R1 ADVNC R3 INTRF	R1 ADVNC R2 INTRF					R1 (LEFT)	R1 (RIGHT)

50157	50156	50155	50154	50153	50152	50151	50150
SOUT#120	SOUT#119	SOUT#118	SOUT#117	SOUT#116	SOUT#115	SOUT#114	SOUT#113
SPHERE INPUT	SPHERE INPUT	CRD WORKING R2, R3	SPHERE INTRF R2, R3	CRD WORKING R4, R2	SPHERE INTRF R4, R2	S-AXIS INTRF	
R2 ADVNC R3 INTRF	R2 ADVNC R1 INTRF					R2 (LEFT)	R2 (RIGHT)

4 Specific I/O Signals
4.7 Specific Output Signals for All Applications

50167	50166	50165	50164	50163	50162	50161	50160
SOUT#128	SOUT#127	SOUT#126	SOUT#125	SOUT#124	SOUT#123	SOUT122	SOUT121
SPHERE INPUT	SPHERE INPUT	CRD WORKING R3, R1	SPHERE INTRF R3, R1	CRD WORKING R4, R3	SPHERE INTRF R4, R3	S-AXIS INTRF	
R3 ADVNC R2 INTRF	R3 ADVNC R1 INTRF					R3 (LEFT)	R3 (RIGHT)

50177	50176	50175	50174	50173	50172	50171	50170
SOUT#136	SOUT#135	SOUT#134	SOUT#133	SOUT#132	SOUT#131	SOUT#130	SOUT#129
SPHERE INPUT	SPHERE INPUT	SPHERE INPUT	SPHERE INPUT	SPHERE INPUT	SPHERE INPUT	S-AXIS INTRF	
R4 ADVNC R3 INTRF	R4 ADVNC R2 INTRF	R4 ADVNC R1 INTRF	R3 ADVNC R4 INTRF	R2 ADVNC R4 INTRF	R1 ADVNC R4 INTRF	R4 (LEFT)	R4 (RIGHT)

50187	50186	50185	50184	50183	50182	50181	50180
SOUT#144	SOUT#143	SOUT#142	SOUT#141	SOUT#140	SOUT#139	SOUT#138	SOUT#137
SERVO ON STATUS S4	SERVO ON STATUS S3	SERVO ON STATUS S2	SERVO ON STATUS S1	SERVO ON STATUS R4	SERVO ON STATUS R3	SERVO ON STATUS R2	SERVO ON STATUS R1

50197	50196	50195	50194	50193	50192	50191	50190
SOUT#152	SOUT#151	SOUT#150	SOUT#149	SOUT#148	SOUT#147	SOUT#146	SOUT#145
SERVO ON STATUS S12	SERVO ON STATUS S11	SERVO ON STATUS S10	SERVO ON STATUS S9	SERVO ON STATUS S8	SERVO ON STATUS S7	SERVO ON STATUS S6	SERVO ON STATUS S5

50207	50206	50205	50204	50203	50202	50201	50200
SOUT#160	SOUT#159	SOUT#158	SOUT#157	SOUT#156	SOUT#155	SOUT#154	SOUT#153
				WAIT JOB SEQ R4J	WAIT JOB SEQ R3J	WAIT JOB SEQ R2J	WAIT JOB SEQ R1J

50217	50216	50215	50214	50213	50212	50211	50210
SOUT#168	SOUT#167	SOUT#166	SOUT#165	SOUT#164	SOUT#163	SOUT#162	SOUT#161

50227	50226	50225	50224	50223	50222	50221	50220
SOUT#176	SOUT#175	SOUT#174	SOUT#173	SOUT#172	SOUT#171	SOUT#170	SOUT#169
				CONTINUE JOB R4J	CONTINUE JOB R3J	CONTINUE JOB R2J	CONTINUE JOB R1J

50237	50236	50235	50234	50233	50232	50231	50230
SOUT#184	SOUT#183	SOUT#182	SOUT#181	SOUT#180	SOUT#179	SOUT#178	SOUT#177

4 Specific I/O Signals

4.7 Specific Output Signals for All Applications

50247	50246	50245	50244	50243	50242	50241	50240
SOUT#192	SOUT#191	SOUT#190	SOUT#189	SOUT#188	SOUT#187	SOUT#186	SOUT#185
				CONTROL GROUP ON R4	CONTROL GROUP ON R3	CONTROL GROUP ON R2	CONTROL GROUP ON R1

50257	50256	50255	50254	50253	50252	50251	50250
SOUT#200	SOUT#199	SOUT#198	SOUT#197	SOUT#196	SOUT#195	SOUT#194	SOUT#193

50267	50266	50265	50264	50263	50262	50261	50260
SOUT#208	SOUT#207	SOUT#206	SOUT#205	SOUT#204	SOUT#203	SOUT#202	SOUT#201
WORK PERMIT RUN R4J	WORK PERMIT RUN R3J	WORK PERMIT RUN R2J	WORK PERMIT RUN R1J	WORK RESTART PROHIBIT R4J	WORK RESTART PROHIBIT R3J	WORK RESTART PROHIBIT R2J	WORK RESTART PROHIBIT R1J

50277	50276	50275	50274	50273	50272	50271	50270
SOUT#216	SOUT#215	SOUT#214	SOUT#213	SOUT#212	SOUT#211	SOUT#210	SOUT#209
SERVO FLOAT ON R4	SERVO FLOAT ON R3	SERVO FLOAT ON R2	SERVO FLOAT ON R1	SEARCHING R4J	SEARCHING R3J	SEARCHING R2J	SEARCHING R1J

50287	50286	50285	50284	50283	50282	50281	50280
SOUT#224	SOUT#223	SOUT#222	SOUT#221	SOUT#220	SOUT#219	SOUT#218	SOUT#217
				LOCUS DEVIATE R4	LOCUS DEVIATE R3	LOCUS DEVIATE R2	LOCUS DEVIATE R1

50297	50296	50295	50294	50293	50292	50291	50290
SOUT#232	SOUT#231	SOUT#230	SOUT#229	SOUT#228	SOUT#227	SOUT#226	SOUT#225

50307	50306	50305	50304	50303	50302	50301	50300
SOUT#240	SOUT#239	SOUT#238	SOUT#237	SOUT#236	SOUT#235	SOUT#234	SOUT#233
				SHOCK DETECTION VALID R4	SHOCK DETECTION VALID R3	SHOCK DETECTION VALID R2	SHOCK DETECTION VALID R1

50317	50316	50315	50314	50313	50312	50311	50310
SOUT#248	SOUT#247	SOUT#246	SOUT#245	SOUT#244	SOUT#243	SOUT#242	SOUT#241

4 Specific I/O Signals
4.7 Specific Output Signals for All Applications

50327	50326	50325	50324	50323	50322	50321	50320
SOUT#256	SOUT#255	SOUT#254	SOUT#253	SOUT#252	SOUT#251	SOUT#250	SOUT#249
SUB MASTER 7 RUN	SUB MASTER 6 RUN	SUB MASTER 5 RUN	SUB MASTER 4 RUN	SUB MASTER 3 RUN	SUB MASTER 2 RUN	SUB MASTER 1 RUN	MASTER JOB RUN

50337	50336	50335	50334	50333	50332	50331	50330
SOUT#264	SOUT#263	SOUT#262	SOUT#261	SOUT#260	SOUT#259	SOUT#258	SOUT#257
SUB MASTER 7 HOLD	SUB MASTER 6 HOLD	SUB MASTER 5 HOLD	SUB MASTER 4 HOLD	SUB MASTER 3 HOLD	SUB MASTER 2 HOLD	SUB MASTER 1 HOLD	MASTER JOB HOLD

50347	50346	50345	50344	50343	50342	50341	50340
SOUT#272	SOUT#271	SOUT#270	SOUT#269	SOUT#268	SOUT#237	SOUT#266	SOUT#265

50357	50356	50355	50354	50353	50352	50351	50350
SOUT#280	SOUT#279	SOUT#278	SOUT#277	SOUT#276	SOUT#275	SOUT#274	SOUT#273
SHOCK DTCT ALM			PLAY MODE ENABLE		MANAGEMENT MODE	EDITING MODE	OPERATION MODE

50367	50366	50365	50364	50363	50362	50361	50360
SOUT#288	SOUT#287	SOUT#286	SOUT#285	SOUT#284	SOUT#283	SOUT#282	SOUT#281

50377	50376	50375	50374	50373	50372	50371	50370
SOUT#296	SOUT#295	SOUT#294	SOUT#293	SOUT#292	SOUT#291	SOUT#290	SOUT#289

50387	50386	50385	50384	50383	50382	50381	50380
SOUT#304	SOUT#303	SOUT#302	SOUT#301	SOUT#300	SOUT#299	SOUT#298	SOUT#297

50397	50396	50395	50394	50393	50392	50391	50390
SOUT#312	SOUT#311	SOUT#310	SOUT#309	SOUT#308	SOUT#307	SOUT#306	SOUT#305

4 Specific I/O Signals

4.7 Specific Output Signals for All Applications

50407	50406	50405	50404	50403	50402	50401	50400
SOUT#320	SOUT#319	SOUT#318	SOUT#317	SOUT#316	SOUT#315	SOUT#314	SOUT#313

50417	50416	50415	50414	50413	50412	50411	50410
SOUT#328	SOUT#327	SOUT#326	SOUT#325	SOUT#324	SOUT#323	SOUT#322	SOUT#321

50427	50426	50425	50424	50423	50422	50421	50420
SOUT#336	SOUT#335	SOUT#334	SOUT#333	SOUT#332	SOUT#331	SOUT#330	SOUT#329

50437	50436	50435	50434	50433	50432	50431	50430
SOUT#344	SOUT#343	SOUT#342	SOUT#341	SOUT#340	SOUT#339	SOUT#338	SOUT#337

50447	50446	50445	50444	50443	50442	50441	50440
SOUT#352	SOUT#351	SOUT#350	SOUT#349	SOUT#348	SOUT#347	SOUT#346	SOUT#345

50457	50456	50455	50454	50453	50452	50451	50450
SOUT#360	SOUT#359	SOUT#358	SOUT#357	SOUT#356	SOUT#355	SOUT#354	SOUT#353

50467	50466	50465	50464	50463	50462	50461	50460
SOUT#368	SOUT#367	SOUT#366	SOUT#365	SOUT#364	SOUT#363	SOUT#362	SOUT#361

50477	50476	50475	50474	50473	50472	50471	50470
SOUT#376	SOUT#375	SOUT#374	SOUT#373	SOUT#372	SOUT#371	SOUT#370	SOUT#369

4 Specific I/O Signals
4.7 Specific Output Signals for All Applications

50487	50486	50485	50484	50483	50482	50481	50480
SOUT#384	SOUT#383	SOUT#382	SOUT#381	SOUT#380	SOUT#379	SOUT#378	SOUT#377

50497	50496	50495	50494	50493	50492	50491	50490
SOUT#392	SOUT#391	SOUT#390	SOUT#389	SOUT#388	SOUT#387	SOUT#386	SOUT#385

50507	50506	50505	50504	50503	50502	50501	50500
SOUT#400	SOUT#399	SOUT#398	SOUT#397	SOUT#396	SOUT#395	SOUT#394	SOUT#393

50517	50516	50515	50514	50513	50512	50511	50510
SOUT#408	SOUT#407	SOUT#406	SOUT#405	SOUT#404	SOUT#403	SOUT#402	SOUT#401

50527	50526	50525	50524	50523	50522	50521	50520
SOUT#416	SOUT#415	SOUT#414	SOUT#413	SOUT#412	SOUT#411	SOUT#410	SOUT#409

50537	50536	50535	50534	50533	50532	50531	50530
SOUT#424	SOUT#423	SOUT#422	SOUT#421	SOUT#420	SOUT#419	SOUT#418	SOUT#417

50547	50546	50545	50544	50543	50542	50541	50540
SOUT#432	SOUT#431	SOUT#430	SOUT#429	SOUT#428	SOUT#427	SOUT#426	SOUT#425

50557	50556	50555	50554	50553	50552	50551	50550
SOUT#440	SOUT#439	SOUT#438	SOUT#437	SOUT#436	SOUT#435	SOUT#434	SOUT#433

4 Specific I/O Signals

4.7 Specific Output Signals for All Applications

50567	50566	50565	50564	50563	50562	50561	50560
SOUT#448	SOUT#447	SOUT#446	SOUT#445	SOUT#444	SOUT#443	SOUT#442	SOUT#441

50577	50576	50575	50574	50573	50572	50571	50570
SOUT#456	SOUT#455	SOUT#454	SOUT#453	SOUT#452	SOUT#451	SOUT#450	SOUT#449

50587	50586	50585	50584	50583	50582	50581	50580
SOUT#464	SOUT#463	SOUT#462	SOUT#461	SOUT#460	SOUT#459	SOUT#458	SOUT#457

50597	50596	50595	50594	50593	50592	50591	50590
SOUT#472	SOUT#471	SOUT#470	SOUT#469	SOUT#468	SOUT#467	SOUT#466	SOUT#465

50607	50606	50605	50604	50603	50602	50601	50600
SOUT#480	SOUT#479	SOUT#478	SOUT#477	SOUT#476	SOUT#475	SOUT#474	SOUT#473

50617	50616	50615	50614	50613	50612	50611	50610
SOUT#488	SOUT#487	SOUT#486	SOUT#485	SOUT#484	SOUT#483	SOUT#482	SOUT#481

50627	50626	50625	50624	50623	50622	50621	50620
SOUT#496	SOUT#495	SOUT#494	SOUT#493	SOUT#492	SOUT#491	SOUT#490	SOUT#489

50637	50636	50635	50634	50633	50632	50631	50630
SOUT#504	SOUT#503	SOUT#502	SOUT#501	SOUT#500	SOUT#499	SOUT#498	SOUT#497

4 Specific I/O Signals
4.7 Specific Output Signals for All Applications

50647	50646	50645	50644	50643	50642	50641	50640
SOUT#512	SOUT#511	SOUT#510	SOUT#509	SOUT#508	SOUT#507	SOUT#506	SOUT#505
					ARITHMTC ERROR FLAG	ARITHMTC ZERO FLAG	ARITHMTC CARRY FLAG

50657	50656	50655	50654	50653	50652	50651	50650
SOUT#520	SOUT#519	SOUT#518	SOUT#517	SOUT#516	SOUT#515	SOUT#514	SOUT#513

50667	50666	50665	50664	50663	50662	50661	50660
SOUT#528	SOUT#527	SOUT#526	SOUT#525	SOUT#524	SOUT#523	SOUT#522	SOUT#521

50677	50676	50675	50674	50673	50672	50671	50670
SOUT#536	SOUT#535	SOUT#534	SOUT#533	SOUT#532	SOUT#531	SOUT#530	SOUT#529

50687	50686	50685	50684	50683	50682	50681	50680
SOUT#544	SOUT#543	SOUT#542	SOUT#541	SOUT#540	SOUT#539	SOUT#538	SOUT#537

50697	50696	50695	50694	50693	50692	50691	50690
SOUT#552	SOUT#551	SOUT#550	SOUT#549	SOUT#548	SOUT#547	SOUT#546	SOUT#545

50707	50706	50705	50704	50703	50702	50701	50700
SOUT#560	SOUT#559	SOUT#558	SOUT#557	SOUT#556	SOUT#555	SOUT#554	SOUT#553

50717	50716	50715	50714	50713	50712	50711	50710
SOUT#568	SOUT#567	SOUT#566	SOUT#565	SOUT#564	SOUT#563	SOUT#562	SOUT#561

4 Specific I/O Signals

4.7 Specific Output Signals for All Applications

50727	50726	50725	50724	50723	50722	50721	50720
SOUT#576	SOUT#575	SOUT#574	SOUT#573	SOUT#572	SOUT#571	SOUT#570	SOUT#569

50737	50736	50735	50734	50733	5073	50731	50730
SOUT#584	SOUT#583	SOUT#582	SOUT#581	SOUT#580	SOUT#579	SOUT#578	SOUT#577

50747	50746	50745	50744	50743	50742	50741	50740
SOUT#592	SOUT#591	SOUT#590	SOUT#589	SOUT#588	SOUT#587	SOUT#586	SOUT#585

50757	50756	50755	50754	50753	50752	50751	50750
SOUT#600	SOUT#599	SOUT#598	SOUT#597	SOUT#596	SOUT#595	SOUT#594	SOUT#593

50767	50766	50765	50764	50763	50762	50761	50760
SOUT#608	SOUT#607	SOUT#606	SOUT#605	SOUT#604	SOUT#603	SOUT#602	SOUT#601

4.8 Specific Output Signals for Arc Welding

Device 1

50777	50776	50775	50774	50773	50772	50771	50770
SOUT#616	SOUT#615	SOUT#614	SOUT#613	SOUT#612	SOUT#611	SOUT#610	SOUT#609
RETURN RETRY	RETRACT	INCHING	CLEAN NOZZLE	TIP CHANGE REQUEST	PROHIBIT WORK CONT	END WORK	START WORK

50787	50786	50785	50784	50783	50782	50781	50780
SOUT#624	SOUT#623	SOUT#622	SOUT#621	SOUT#620	SOUT#619	SOUT#618	SOUT#617
RETRY REPLAY MODE	OVER ANTI- STICK NO	OVER RESTART	OVER RETRY	RETURN RESTART	RESTARTING / WIRE	RESTARTING / GAS	RESTARTING / ARC

50797	50796	50795	50794	50793	50792	50791	50790
SOUT#632	SOUT#631	SOUT#630	SOUT#629	SOUT#628	SOUT#627	SOUT#626	SOUT#625

50807	50806	50805	50804	50803	50802	50801	50800
SOUT#640	SOUT#639	SOUT#638	SOUT#637	SOUT#636	SOUT#635	SOUT#634	SOUT#633

50817	50816	50815	50814	50813	50812	50811	50810
SOUT#648	SOUT#647	SOUT#646	SOUT#645	SOUT#644	SOUT#643	SOUT#642	SOUT#641

50827	50826	50825	50824	50823	50822	50821	50820
SOUT#656	SOUT#655	SOUT#654	SOUT#653	SOUT#652	SOUT#651	SOUT#650	SOUT#649

4 Specific I/O Signals

4.8 Specific Output Signals for Arc Welding

Device 2

50837	50836	50835	50834	50833	50832	80531	50830
SOUT#664	SOUT#663	SOUT#662	SOUT#661	SOUT#660	SOUT#659	SOUT#658	SOUT#657
RETURN RETRY	RETRACT	INCHING	CLEAN NOZZLE	TIP CHANGE REQUEST	PROHIBIT WORK CONT	END WORK	START WORK

50847	50846	50845	50844	50843	50842	50841	50840
SOUT#672	SOUT#671	SOUT#670	SOUT#669	SOUT#668	SOUT#667	SOUT#666	SOUT#665
RETRY REPLAY MODE	OVER ANTI- STICK NO	OVER RESTART	OVER RETRY	RETURN RESTART	RESTARTING / WIR	RESTARTING / GAS	RESTARTING / ARC

50857	50856	50855	50854	50853	50852	50851	50850
SOUT#680	SOUT#679	SOUT#678	SOUT#677	SOUT#676	SOUT#675	SOUT#674	SOUT#673

50867	50866	50865	50864	50863	50862	50861	50860
SOUT#688	SOUT#687	SOUT#686	SOUT#685	SOUT#684	SOUT#683	SOUT#682	SOUT#681

50877	50876	50875	50874	50873	50872	50871	50870
SOUT#696	SOUT#695	SOUT#694	SOUT#693	SOUT#692	SOUT#691	SOUT#690	SOUT#689

50887	50886	50885	50884	50883	50882	50881	50880
SOUT#704	SOUT#703	SOUT#702	SOUT#701	SOUT#700	SOUT#699	SOUT#698	SOUT#697

Device 3

50897	50896	50895	50894	50893	50892	50891	50890
SOUT#712	SOUT#711	SOUT#710	SOUT#709	SOUT#708	SOUT#707	SOUT#706	SOUT#705
RETURN RETRY	RETRACT	INCHING	CLEAN NOZZLE	TIP CHANGE REQUEST	PROHIBIT WORK CONTINUE	END WORK	START WORK

50907	50506	50905	50904	50903	50902	50901	50900
SOUT#720	SOUT#719	SOUT#718	SOUT#717	SOUT#716	SOUT#715	SOUT#714	SOUT#713
RETRY REPLAY MODE	OVER ANTI- STICK NO	OVER RESTART	OVER RETRY	RETURN RESTART	RESTARTING / WIR	RESTARTING / GAS	RESTARTING / ARC

50917	50916	50915	50914	50913	50912	50911	50910
SOUT#728	SOUT#727	SOUT#726	SOUT#725	SOUT#724	SOUT#723	SOUT#722	SOUT#721

50927	50926	50925	50924	50923	50922	50921	50920
SOUT#736	SOUT#735	SOUT#734	SOUT#733	SOUT#732	SOUT#731	SOUT#730	SOUT#729

50937	50936	50935	50934	50933	50932	50931	50930
SOUT#744	SOUT#743	SOUT#742	SOUT#741	SOUT#740	SOUT#739	SOUT#738	SOUT#737

50947	50976	50945	50944	50943	50942	50941	50940
SOUT#752	SOUT#751	SOUT#750	SOUT#749	SOUT#748	SOUT#747	SOUT#746	SOUT#745

4 Specific I/O Signals

4.8 Specific Output Signals for Arc Welding

Device 4

50957	50956	50955	50954	50953	50952	50951	50950
SOUT#760	SOUT#759	SOUT#758	SOUT#757	SOUT#756	SOUT#755	SOUT#754	SOUT#753
RETURN RETRY	RETRACT	INCHING	CLEAN NOZZLE	TIP CHANGE REQUEST	PROHIBIT WORK CONTINUE	END WORK	START WORK

50967	50966	50965	50964	50963	50962	50961	50960
SOUT#768	SOUT#767	SOUT#766	SOUT#765	SOUT#764	SOUT#763	SOUT#762	SOUT#761
RETRY REPLAY MODE	OVER ANTI- STICK NO	OVER RESTART	OVER RETRY	RETURN RESTART	RESTARTING / WIR	RESTARTING /GAS	RESTARTING / ARC

50977	50976	50975	50974	50973	50972	50971	50970
SOUT#776	SOUT#775	SOUT#774	SOUT#773	SOUT#772	SOUT#771	SOUT#770	SOUT#769

50987	50986	50985	50984	50983	50982	50981	50980
SOUT#784	SOUT#783	SOUT#782	SOUT#781	SOUT#780	SOUT#779	SOUT#778	SOUT#777

50997	50996	50995	50994	50993	50992	50991	50990
SOUT#792	SOUT#791	SOUT#790	SOUT#789	SOUT#788	SOUT#787	SOUT#786	SOUT#785

51007	51006	51005	51004	51003	51002	51001	51000
SOUT#800	SOUT#799	SOUT#798	SOUT#797	SOUT#796	SOUT#795	SOUT#794	SOUT#793

4.9 Specific Output Signals for Handling

Device 1

50777	50776	50775	50774	50773	50772	50771	50770
SOUT#616	SOUT#615	SOUT#614	SOUT#613	SOUT#612	SOUT#611	SOUT#610	SOUT#609
SH-SNSR VALID	SH-SNSR FUNCTION SELECT				PROHIBIT WORK CONTINUE	END WORK	START WORK

50787	50786	50785	50784	50783	50782	50781	50780
SOUT#624	SOUT#623	SOUT#622	SOUT#621	SOUT#620	SOUT#619	SOUT#618	SOUT#617
TOOL VALVE 4-2	TOOL VALVE 4-1	TOOL VALVE 3-2	TOOL VALVE 3-1	TOOL VALVE 2-2	TOOL VALVE 2-1	TOOL VALVE 1-2	TOOL VALVE 1-1

50797	50796	50795	50794	50793	50792	50791	50790
SOUT#632	SOUT#631	SOUT#630	SOUT#629	SOUT#628	SOUT#627	SOUT#626	SOUT#625

50807	50806	50805	50804	50803	50802	50801	50800
SOUT#640	SOUT#639	SOUT#638	SOUT#637	SOUT#636	SOUT#635	SOUT#634	SOUT#633

50817	50816	50815	50814	50813	50812	50811	50810
SOUT#648	SOUT#647	SOUT#646	SOUT#645	SOUT#644	SOUT#643	SOUT#642	SOUT#641

50827	50826	50825	50824	50823	50822	50821	50820
SOUT#656	SOUT#655	SOUT#654	SOUT#653	SOUT#652	SOUT#651	SOUT#650	SOUT#649

4 Specific I/O Signals

4.9 Specific Output Signals for Handling

Device 2

50837	50836	50835	50834	50833	50832	80531	50830
SOUT#664	SOUT#663	SOUT#662	SOUT#661	SOUT#660	SOUT#659	SOUT#658	SOUT#657
SH-SNSR VALID	SH-SNSR FUNCTION SELECT				PROHIBIT WORK CONTINUE	END WORK	START WORK

50847	50846	50845	50844	50843	50842	50841	50840
SOUT#672	SOUT#671	SOUT#670	SOUT#669	SOUT#668	SOUT#667	SOUT#666	SOUT#665
TOOL VALVE 4-2	TOOL VALVE 4-1	TOOL VALVE 3-2	TOOL VALVE 3-1	TOOL VALVE 2-2	TOOL VALVE 2-1	TOOL VALVE 1-2	TOOL VALVE 1-1

50857	50856	50855	50854	50853	50852	50851	50850
SOUT#680	SOUT#679	SOUT#678	SOUT#677	SOUT#676	SOUT#675	SOUT#674	SOUT#673

50867	50866	50865	50864	50863	50862	50861	50860
SOUT#688	SOUT#687	SOUT#686	SOUT#685	SOUT#684	SOUT#683	SOUT#682	SOUT#681

50877	50876	50875	50874	50873	50872	50871	50870
SOUT#696	SOUT#695	SOUT#694	SOUT#693	SOUT#692	SOUT#691	SOUT#690	SOUT#689

50887	50886	50885	50884	50883	50882	50881	50880
SOUT#704	SOUT#703	SOUT#702	SOUT#701	SOUT#700	SOUT#699	SOUT#698	SOUT#697

Device 3

50897	50896	50895	50894	50893	50892	50891	50890
SOUT#712	SOUT#711	SOUT#710	SOUT#709	SOUT#708	SOUT#707	SOUT#706	SOUT#705
SH-SNSR VALID	SH-SNSR FUNCTION SELECT				PROHIBIT WORK CONTINUE	END WORK	START WORK

50907	50506	50905	50904	50903	50902	50901	50900
SOUT#720	SOUT#719	SOUT#718	SOUT#717	SOUT#716	SOUT#715	SOUT#714	SOUT#713
TOOL VALVE 4-2	TOOL VALVE 4-1	TOOL VALVE 3-2	TOOL VALVE 3-1	TOOL VALVE 2-2	TOOL VALVE 2-1	TOOL VALVE 1-2	TOOL VALVE 1-1

50917	50916	50915	50914	50913	50912	50911	50910
SOUT#728	SOUT#727	SOUT#726	SOUT#725	SOUT#724	SOUT#723	SOUT#722	SOUT#721

50927	50926	50925	50924	50923	50922	50921	50920
SOUT#736	SOUT#735	SOUT#734	SOUT#733	SOUT#732	SOUT#731	SOUT#730	SOUT#729

50937	50936	50935	50934	50933	50932	50931	50930
SOUT#744	SOUT#743	SOUT#742	SOUT#741	SOUT#740	SOUT#739	SOUT#738	SOUT#737

50947	50976	50945	50944	50943	50942	50941	50940
SOUT#752	SOUT#751	SOUT#750	SOUT#749	SOUT#748	SOUT#747	SOUT#746	SOUT#745

4 Specific I/O Signals

4.9 Specific Output Signals for Handling

Device 4

50957	50956	50955	50954	50953	50952	50951	50950
SOUT#760	SOUT#759	SOUT#758	SOUT#757	SOUT#756	SOUT#755	SOUT#754	SOUT#753
SH-SNSR VALID	SH-SNSR FUNCTION SELECT				PROHIBIT WORK CONT	END WORK	START WORK

50967	50966	50965	50964	50963	50962	50961	50960
SOUT#768	SOUT#767	SOUT#766	SOUT#765	SOUT#764	SOUT#763	SOUT#762	SOUT#761
TOOL VALVE 4-2	TOOL VALVE 4-1	TOOL VALVE 3-2	TOOL VALVE 3-1	TOOL VALVE 2-2	TOOL VALVE 2-1	TOOL VALVE 1-2	TOOL VALVE 1-1

50977	50976	50975	50974	50973	50972	50971	50970
SOUT#776	SOUT#775	SOUT#774	SOUT#773	SOUT#772	SOUT#771	SOUT#770	SOUT#769

50987	50986	50985	50984	50983	50982	50981	50980
SOUT#784	SOUT#783	SOUT#782	SOUT#781	SOUT#780	SOUT#779	SOUT#778	SOUT#777

50997	50996	50995	50994	50993	50992	50991	50990
SOUT#792	SOUT#791	SOUT#790	SOUT#789	SOUT#788	SOUT#787	SOUT#786	SOUT#785

51007	51006	51005	51004	51003	51002	51001	51000
SOUT#800	SOUT#799	SOUT#798	SOUT#797	SOUT#796	SOUT#795	SOUT#794	SOUT#793

4.10 Specific Output Signals for Spot Welding

Device 1

50777	50776	50775	50774	50773	50772	50771	50770
SOUT#616	SOUT#615	SOUT#614	SOUT#613	SOUT#612	SOUT#611	SOUT#610	SOUT#609
WELDING ON/OFF	WORK SVSPOT WELD 1	TIP CHANGE ALARM WELD 1	WEAR DETECT ERROR WELD 1	WEAR DETECT NORMAL WELD 1			

50787	50786	50785	50784	50783	50782	50781	50780
SOUT#624	SOUT#623	SOUT#622	SOUT#621	SOUT#620	SOUT#619	SOUT#618	SOUT#617
	WORK SVSPOT WELD 2	TIP CHANGE ALARM WELD 2	WEAR DETECT ERROR WELD 2	WEAR DETECT NORMAL WELD 2			SENSOR SEARCHING WELD 1

50797	50796	50795	50794	50793	50792	50791	50790
SOUT#632	SOUT#631	SOUT#630	SOUT#629	SOUT#628	SOUT#627	SOUT#626	SOUT#625
	WORK SVSPOT WELD 3	TIP CHANGE ALARM WELD 3	WEAR DETECT ERROR WELD 3	WEAR DETECT NORMAL WELD 3			SENSOR SEARCHING WELD 2

50807	50806	50805	50804	50803	50802	50801	50800
SOUT#640	SOUT#639	SOUT#638	SOUT#637	SOUT#636	SOUT#635	SOUT#634	SOUT#633
	WORK SVSPOT WELD 4	TIP CHANGE ALARM WELD 4	WEAR DETECT ERROR WELD 4	WEAR DETECT NORMAL WELD 4			SENSOR SEARCHING WELD 3

50817	50816	50815	50814	50813	50812	50811	50810
SOUT#648	SOUT#647	SOUT#646	SOUT#645	SOUT#644	SOUT#643	SOUT#642	SOUT#641
							SENSOR SEARCHING WELD 4

50827	50826	50825	50824	50823	50822	50821	50820
SOUT#656	SOUT#655	SOUT#654	SOUT#653	SOUT#652	SOUT#651	SOUT#650	SOUT#649

4 Specific I/O Signals

4.10 Specific Output Signals for Spot Welding

Device 2

50837	50836	50835	50834	50833	50832	80531	50830
SOUT#664	SOUT#663	SOUT#662	SOUT#661	SOUT#660	SOUT#659	SOUT#658	SOUT#657

50847	50846	50845	50844	50843	50842	50841	50840
SOUT#672	SOUT#671	SOUT#670	SOUT#669	SOUT#668	SOUT#667	SOUT#666	SOUT#665

50857	50856	50855	50854	50853	50852	50851	50850
SOUT#680	SOUT#679	SOUT#678	SOUT#677	SOUT#676	SOUT#675	SOUT#674	SOUT#673

50867	50866	50865	50864	50863	50862	50861	50860
SOUT#688	SOUT#687	SOUT#686	SOUT#685	SOUT#684	SOUT#683	SOUT#682	SOUT#681

50877	50876	50875	50874	50873	50872	50871	50870
SOUT#696	SOUT#695	SOUT#694	SOUT#693	SOUT#692	SOUT#691	SOUT#690	SOUT#689

50887	50886	50885	50884	50883	50882	50881	50880
SOUT#704	SOUT#703	SOUT#702	SOUT#701	SOUT#700	SOUT#699	SOUT#698	SOUT#697

Device 3

50897	50896	50895	50894	50893	50892	50891	50890
SOUT#712	SOUT#711	SOUT#710	SOUT#709	SOUT#708	SOUT#707	SOUT#706	SOUT#705

50907	50506	50905	50904	50903	50902	50901	50900
SOUT#720	SOUT#719	SOUT#718	SOUT#717	SOUT#716	SOUT#715	SOUT#714	SOUT#713

50917	50916	50915	50914	50913	50912	50911	50910
SOUT#728	SOUT#727	SOUT#726	SOUT#725	SOUT#724	SOUT#723	SOUT#722	SOUT#721

50927	50926	50925	50924	50923	50922	50921	50920
SOUT#736	SOUT#735	SOUT#734	SOUT#733	SOUT#732	SOUT#731	SOUT#730	SOUT#729

50937	50936	50935	50934	50933	50932	50931	50930
SOUT#744	SOUT#743	SOUT#742	SOUT#741	SOUT#740	SOUT#739	SOUT#738	SOUT#737

50947	50976	50945	50944	50943	50942	50941	50940
SOUT#752	SOUT#751	SOUT#750	SOUT#749	SOUT#748	SOUT#747	SOUT#746	SOUT#745

4 Specific I/O Signals

4.10 Specific Output Signals for Spot Welding

Device 4

50957	50956	50955	50954	50953	50952	50951	50950
SOUT#760	SOUT#759	SOUT#758	SOUT#757	SOUT#756	SOUT#755	SOUT#754	SOUT#753

50967	50966	50965	50964	50963	50962	50961	50960
SOUT#768	SOUT#767	SOUT#766	SOUT#765	SOUT#764	SOUT#763	SOUT#762	SOUT#761

50977	50976	50975	50974	50973	50972	50971	50970
SOUT#776	SOUT#775	SOUT#774	SOUT#773	SOUT#772	SOUT#771	SOUT#770	SOUT#769

50987	50986	50985	50984	50983	50982	50981	50980
SOUT#784	SOUT#783	SOUT#782	SOUT#781	SOUT#780	SOUT#779	SOUT#778	SOUT#777

50997	50996	50995	50994	50993	50992	50991	50990
SOUT#792	SOUT#791	SOUT#790	SOUT#789	SOUT#788	SOUT#787	SOUT#786	SOUT#785

51007	51006	51005	51004	51003	51002	51001	51000
SOUT#800	SOUT#799	SOUT#798	SOUT#797	SOUT#796	SOUT#795	SOUT#794	SOUT#793

4.11 Specific Output Signals for General-Purpose Applications

Device 1

50777	50776	50775	50774	50773	50772	50771	50770
SOUT#616	SOUT#615	SOUT#614	SOUT#613	SOUT#612	SOUT#611	SOUT#610	SOUT#609
					PROHIBIT WORK CONTINUE	END WORK	START WORK

50787	50786	50785	50784	50783	50782	50781	50780
SOUT#624	SOUT#623	SOUT#622	SOUT#621	SOUT#620	SOUT#619	SOUT#618	SOUT#617

50797	50796	50795	50794	50793	50792	50791	50790
SOUT#632	SOUT#631	SOUT#630	SOUT#629	SOUT#628	SOUT#627	SOUT#626	SOUT#625

50807	50806	50805	50804	50803	50802	50801	50800
SOUT#640	SOUT#639	SOUT#638	SOUT#637	SOUT#636	SOUT#635	SOUT#634	SOUT#633

50817	50816	50815	50814	50813	50812	50811	50810
SOUT#648	SOUT#647	SOUT#646	SOUT#645	SOUT#644	SOUT#643	SOUT#642	SOUT#641

50827	50826	50825	50824	50823	50822	50821	50820
SOUT#656	SOUT#655	SOUT#654	SOUT#653	SOUT#652	SOUT#651	SOUT#650	SOUT#649

4 Specific I/O Signals

4.11 Specific Output Signals for General-Purpose Applications

Device 2

50837	50836	50835	50834	50833	50832	80531	50830
SOUT#664	SOUT#663	SOUT#662	SOUT#661	SOUT#660	SOUT#659	SOUT#658	SOUT#657
					PROHIBIT WORK CONTINUE	END WORK	START WORK

50847	50846	50845	50844	50843	50842	50841	50840
SOUT#672	SOUT#671	SOUT#670	SOUT#669	SOUT#668	SOUT#667	SOUT#666	SOUT#665

50857	50856	50855	50854	50853	50852	50851	50850
SOUT#680	SOUT#679	SOUT#678	SOUT#677	SOUT#676	SOUT#675	SOUT#674	SOUT#673

50867	50866	50865	50864	50863	50862	50861	50860
SOUT#688	SOUT#687	SOUT#686	SOUT#685	SOUT#684	SOUT#683	SOUT#682	SOUT#681

50877	50876	50875	50874	50873	50872	50871	50870
SOUT#696	SOUT#695	SOUT#694	SOUT#693	SOUT#692	SOUT#691	SOUT#690	SOUT#689

50887	50886	50885	50884	50883	50882	50881	50880
SOUT#704	SOUT#703	SOUT#702	SOUT#701	SOUT#700	SOUT#699	SOUT#698	SOUT#697

4 Specific I/O Signals

4.11 Specific Output Signals for General-Purpose Applications

Device 3

50897	50896	50895	50894	50893	50892	50891	50890
SOUT#712	SOUT#711	SOUT#710	SOUT#709	SOUT#708	SOUT#707	SOUT#706	SOUT#705
					PROHIBIT WORK CONTINUE	END WORK	START WORK

50907	50506	50905	50904	50903	50902	50901	50900
SOUT#720	SOUT#719	SOUT#718	SOUT#717	SOUT#716	SOUT#715	SOUT#714	SOUT#713

50917	50916	50915	50914	50913	50912	50911	50910
SOUT#728	SOUT#727	SOUT#726	SOUT#725	SOUT#724	SOUT#723	SOUT#722	SOUT#721

50927	50926	50925	50924	50923	50922	50921	50920
SOUT#736	SOUT#735	SOUT#734	SOUT#733	SOUT#732	SOUT#731	SOUT#730	SOUT#729

50937	50936	50935	50934	50933	50932	50931	50930
SOUT#744	SOUT#743	SOUT#742	SOUT#741	SOUT#740	SOUT#739	SOUT#738	SOUT#737

50947	50976	50945	50944	50943	50942	50941	50940
SOUT#752	SOUT#751	SOUT#750	SOUT#749	SOUT#748	SOUT#747	SOUT#746	SOUT#745

4 Specific I/O Signals

4.11 Specific Output Signals for General-Purpose Applications

Device 4

50957	50956	50955	50954	50953	50952	50951	50950
SOUT#760	SOUT#759	SOUT#758	SOUT#757	SOUT#756	SOUT#755	SOUT#754	SOUT#753

50967	50966	50965	50964	50963	50962	50961	50960
SOUT#768	SOUT#767	SOUT#766	SOUT#765	SOUT#764	SOUT#763	SOUT#762	SOUT#761

50977	50976	50975	50974	50973	50972	50971	50970
SOUT#776	SOUT#775	SOUT#774	SOUT#773	SOUT#772	SOUT#771	SOUT#770	SOUT#769

50987	50986	50985	50984	50983	50982	50981	50980
SOUT#784	SOUT#783	SOUT#782	SOUT#781	SOUT#780	SOUT#779	SOUT#778	SOUT#777

50997	50996	50995	50994	50993	50992	50991	50990
SOUT#792	SOUT#791	SOUT#790	SOUT#789	SOUT#788	SOUT#787	SOUT#786	SOUT#785

51007	51006	51005	51004	51003	51002	51001	51000
SOUT#800	SOUT#799	SOUT#798	SOUT#797	SOUT#796	SOUT#795	SOUT#794	SOUT#793

4.12 Specific Output Signals: Explanation

The following symbols are used in the explanation to represent the signal conditions.



The signal takes effect while it is in the on state.



The rising edge is detected as the signal.

4.12.1 Alarms and Messages Display

■ 50010 to 50014: ALARM/ERROR OCCURRENCE



These signals indicate the occurrence of alarms or errors. The “MAJOR ALM OCCUR” (50010) signal remains ON until power is turned off.

Register M340 Alarm Code (Binary/BCD)

If an alarm occurs in the system, the corresponding alarm code is output. If there are two or more alarms, the code of the first occurring alarm is output. To switch binary and BCD data type, use the parameter (S2C233). Factory setting is binary.

Register M341, 342 Alarm Data (Binary/BCD)

This data is detailed information added to the alarm code.

■ 50015, 50016: BATTERY WEAK



These signals are turned ON to indicate that batteries need replacement when voltage drops in the memory protection battery and the absolute encoder memory retention battery. Loss of data in memory due to a weak battery causes much damage. Take the signals as a kind of alarm and take appropriate action.

■ 50017: COOLING FAN ERROR



This signal is turned ON to inform that the cooling fan is required to be changed when the CPU rack cooling fan inside NX100 or the cooling fan connected to the power on unit is not operating normally. Such an error as non-operating cooling fan causes damages to NX100 and robot components.

Take the signal as a kind of alarm and take appropriate action.

4 Specific I/O Signals

4.12 Specific Output Signals: Explanation

4.12.2 Setting of Mode / Cycle and Particular Play Operation

■ 50050 to 50052: CYCLE SETTING



These signals indicate the status of specifications of current cycle setting. The signal corresponding to the selected cycle is turned on.

■ 50053 to 50054: MODE SETTING



These signals indicate the status of specifications of current mode settings. The signals are synchronized with the mode select key lamps on the front door of the NX100. The signal corresponding to the selected mode is turned on.

■ 50056: COMMAND REMOTE SETTING



This signal indicates that the command remote function such as transmission is valid.

■ 50060: IN-GUARD SAFE OPERATION SETTING



This signal indicates that the manipulator is in the in-guard safe operation status.

■ 50061: DRY-RUN SETTING



This signal indicates that the dry-run is set.

■ 50062: MACHINE LOCK SETTING



This signal indicates that the machine lock is set.

■ 50063: SOFT LIMIT RELEASE SETTING



This signal indicates that the soft limit is released. Switching to the play mode releases the soft limit automatically and turns off this signal.

■ 50064: CHECK RUN SETTING



This signal indicates the check run is set.

4.12.3 Start and Stop Signals

■ 50020: HEAD OF MASTER JOB



This signal indicates that the execution position is at the head of the master job. The signal can be used as a check signal calling for master job.

■ 50065: PERMISSIBLE WORK IN TEST RUN (FOR ARC ONLY)



The signal turns ON while the [INTERLOCK]+[WELD ON/OFF] keys are pressed simultaneously. The LED on the [WELD ON/OFF] button is lit while the signal is ON. This signal takes effect only in the teach mode.

■ 50066: POSITION CHECK COMPLETED



This signal indicates that the position check operation has been completed after "Alarm 4107: OUT OF RANGE (ABS DATA)" occurred. The signal stays ON if the alarm does not occur after power ON.

■ 50067: FULL SPEED RUNNING



This signal indicates that the manipulator is running in the condition that the safe speed limit is released.

■ 50070: RUNNING (Start Lamp)



This signal indicates that the manipulator is running. That is, the manipulator is either executing jobs, ready for reserved starting, ready for multi-series starting, or performing test run. This signal is synchronized with the state of the "START" button on the programming pendant.

■ 50071: HOLDING (Hold Lamp)



This signal indicates that the manipulator is in the "HOLDING" status as "HOLD" being instructed. This signal is synchronized with the state of the "HOLD" button on the programming pendant.

■ 50073: SERVO ON



This signal indicates that after the servo power is turned on, internal processing such as current position setting has been completed and the system is ready to accept "START" instruction. This can be used for determining external starting conditions.

■ 50074: I/O SIMULATED



This signal indicates any of the signals that are in the simulation mode in the IO windows.

■ 50075: JOB EDITING OPERATION INDICATION



This signal indicates that the job to be executed has just been edited, searched, or manipulated with the cursor on. This can be used for determining starting conditions after editing.

■ 50076: JOG OPERATION INDICATION



This signal indicates that the manipulator was made to move an axis or followed the FWD/BWD operation on the programming pendant. This signal goes OFF automatically when playback is started. This can be used for determining restarting condition.

4 Specific I/O Signals

4.12 Specific Output Signals: Explanation

■ 50077: OT RELEASE



This signal indicates that the overrun status is released.

■ 50180 to 50197: SERVO ON STATUS



These signals indicate that the servo power for each robot/station is ON. With the signal ON, the corresponding servo power for each robot/station is ON.

■ 50200, 50201, 50202, 50203: SEQUENCE WAITING



These signals indicate that the manipulator is stopped by the "SEQUENCE WAIT" (40090, 40091, 40092, or 40093) signal. After accepting the above signal and the manipulator has stopped, these signals go ON. When sequence wait is cleared, these signals go OFF before the manipulator starts operating.

■ 50220, 50221, 50222, 50223: SEQUENCE CONTINUING



These signals indicate that manipulator operation is in executing state in the sequence of instruction as taught. These signals go ON when the initial job is executed after the power is turned on.

The same conditions as above are applied to the "FWD" and "TEST" operations on the programming pendant.

These signals go OFF in the following cases.

- When the cursor is moved by the operation such as change of the line No. with the programming pendant at the manipulator stop.
- When a different job is called up.
- When edit operation (insertion, modification, deletion) is executed from the programming pendant.

For a system with one manipulator, use signal No. 50220.

<Example>

These signals can be used for intentional reset of work section information as shown below.

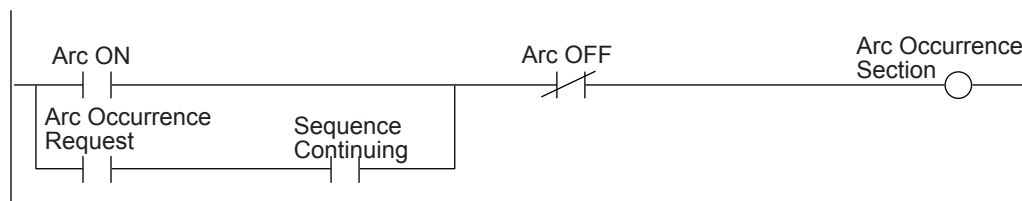

■ 50240 to 50243: CONTROL GROUP RUNNING



This signal indicates that the manipulator is running (segment data is not equal to 0)

■ 50260, 50261, 50262, 50283: WORK RESTART PROHIBIT



When an emergency stop is executed during running at high-speed, the job instruction stop position may advance from the actual manipulator position due to the servo delay. At restarting, the manipulator moves adjusting this delay, then the job is executed. When the instruction stop position is in the work section of arc welding, etc., these signals are ON until the manipulator moves for the delay to reach the position of work start (Arc ON, etc.). and indicate the work restart prohibited status.

For a system with one manipulator, use signal No. 50260 (R1).

■ 50264, 50265, 50266, 50267: PERMISSIBLE WORK RUNNING



These signals indicate that the manipulator is running at the actual workable speed. These signals are turned on being synchronized with "RUNNING" (50264) signal. The status of these signals during operations other than normal playback operation are shown below. .

State 0 : OFF 1 : ON	Meaning
0	<ul style="list-style-type: none"> • Machine Lock Operation • Dry-Run Operation • Low-Speed Start-Up Operation
1	<ul style="list-style-type: none"> • During in-guard safety operation • During continuous operation with the programming pendant • When adjusting speed during operation • When speed is limited by the sensor

For a system with one manipulator, use R1J (50264)

■ 50270, 50271, 50272, 50273: SEARCH START



These signals indicate that "SEARCH" instruction being executed. These signals can be used as effective sensing signals for external sensor.

For a system with one manipulator, use signal No. 50270.

■ 50280, 50281, 50282, 50283: LOCUS DEVIATION



These signals indicate that the corresponding manipulators are deviating from the natural locus, as jog operation after the emergency stop or motion stop.

For a system with one manipulator, use signal No. 50280.

■ 50350, 50351, 50352: SECURITY MODE



These signals indicate the current setting of security mode.
50350: Operation mode
50351: Editing mode
50352: Management mode

4 Specific I/O Signals

4.12 Specific Output Signals: Explanation

■ 50354: PLAY MODE ENABLE



This signal indicates that the play mode enable signal is turned on after changing the mode to PLAY in the play mode enable function.

4.12.4 Interference Signals

■ 50080 to 50117: IN-CUBE



These signals indicate the area in which the current control point is positioned, or in which the axis is positioned in the initially set area. Set the area by parameters (S2C003 to S2C114, S3C032 to S2C543). These can be used to prevent interference with other manipulators or jigs.

■ 50140, 50141, 50150, 50151, 50160, 50161, 50170, 50171: S-AXIS INTERFERENCE AREA



These signals indicate the area in which the current S-Axis is positioned in the initially set area. Set the area by parameters (S2C002, S3C024 to S3C031). These can be used to prevent interference with other manipulators or jigs.

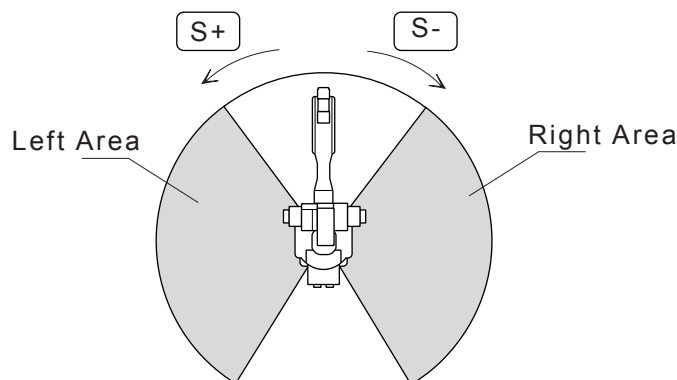

Relation Between the Area and the Signal

■ 50142, 50144, 50146, 50147, 50152, 50154, 50156, 50157, 50162, 50164, 50166, 50167, 50172 to 50177: MOVING SPHERE INTERFERENCE AREA



These signals indicate that interference exists by the moving sphere interference check. Set the areas by parameters (S2C188 to S2C193, S3C801 to S3C804). These signals can be used to check interference of two or more manipulators.

4.12.5 Arithmetic Instruction Signal

■ 50640, 50641, 50642: Arithmetic Flag



These signals reflect the result of the arithmetic instruction in the following steps. There are three kinds of flag: Carry Flag (50640), Zero Flag (50641), and Error Flag (50642).

4.12.6 Signals During Operation and for Jog Offset Junction (Optional)

- 50021, 50022, 50023, 50024, 50025, 50026, 50027: TOP SUB 1, 2, 3, 4, 5, 6, 7 MASTER



These signals indicate that the execution position is at the head of the master job in sub task 1, 2, 3, 4, 5, 6, or 7. Use as a checking signal of master job in each sub task call.

- 50031, 50032, 50033, 50034, 50035, 50036, 50037: SUB HELD



These signals indicate sub task 1, 2, 3, 4, 5, 6, or 7 stops the operation by alarm occurrence or the "PAUSE" instruction. Operation can be restarted by pressing the [START] key on the front door of the NX100 or inputting external start (40044).

These signals are turned off when all tasks stop or the sub task is released.

- 50041, 50042, 50043, 50044, 50045, 50046, 50047: SUB ALARM OCCUR



These signals indicate that the sub task is generating an alarm individually during the system section alarm occurrence (50012) or user section alarm occurrence (50013).

State 0:OFF 1:ON							Meaning
50047	50046	50045	50044	50043	50042	50041	
0	0	0	0	0	0	0	All tasks alarms occur
0	0	0	0	0	0	1	Sub task 1 alarm occurs
:	:	:	:	:	:	:	:
1	1	1	1	1	1	1	Sub tasks 1, 2, 3, 4, 5, 6, 7 alarms occur

4 Specific I/O Signals

4.12 Specific Output Signals: Explanation

■ 50143, 50145, 50153, 50155, 50163, 50165: CRD WORKING



These signals indicate coordination jobs are working. The signals are turned off when the job stops (the start lamp goes OFF).

Combination of the robots are as follows:

Signals	Combination of the Robots
50143	R1 and R4
50145	R1 and R2
50153	R2 and R4
50155	R2 and R3
50163	R3 and R4
50165	R3 and R1

■ 50320 to 50327: SUB 1, 2, 3, 4, 5, 6, 7, MASTER OPERATING



These signals indicate that the robot is operating by sub task 1, 2, 3, 4, 5, 6, 7, and the master job signals.

■ 50330 to 50337: SUB 1, 2, 3, 4, 5, 6, 7, MASTER HOLDING



These signals indicate that the robot is holding by sub task 1, 2, 3, 4, 5, 6, 7, and the master job signals.

4.12.7 Signals for Servo Float Function (Optional)

■ 50274, 50275, 50276, 50277: SERVO FLOAT ON



These signals indicate the servo float operating status.

In the system with one manipulator, use signal No. 50274 (R1).

■ 50300 to 50303: SHOCK DETECTION VALID



This signal indicates that the shock detection function is valid.

■ 50357: SHOCK DTCT ALM



This signal indicates that the shock detection alarm "4315: SHOCK DETECTION" currently occurs.

4.12.8 Singals for Arc Welding

Signals from 50770 to 51007 are classified into four blocks and assigned to output signals that have different meanings depending on the application. Most of these outputs are used by the system so they cannot be used from the outside of the NX100. This section explains exceptional signals that are available for external use.

■ 50770, 50830, 50890, 50950: WORK START Instructions



These signals indicate work starting and wait for inputting of the “WORK START RESPONSE” (40570, 40630, 40690, 40750) signal.

For a system with one application, use signal No. 50770.

■ 50771, 50831, 50891, 50951: WORK END Instructions



These signals indicate work ending and wait for inputting of the “WORK END RESPONSE” (40571, 40631, 40691, 40751) signal.

For a system with one application, use signal No. 50771.

■ 50772, 50832, 50892, 50952: WORK CONTINUING PROHIBIT Instructions



These signals indicate whether to continue the operation when resuming after stopping during the operation. When the signals are on, the operation is not continued.

For a system with one application, use signal No. 50772.

■ 50773, 50833, 50893, 50953: TIP REPLACEMENT REQUEST



These signals indicate that the preset tip replacement time has come. The signals are reset by the “TIP REPLACEMENT COMPLETED” (40573, 40633, 40693, 40753) signals.

For a system with one application, use signal No. 50773.

■ 50774, 50834, 50894, 50954: NOZZLE CLEANING REQUEST



These signals indicate that the set nozzle cleaning request time has come. These signals are reset by “NOZZLE CLEANED” (40574, 40634, 40694, 40754) signals.

For a system with one application, use signal No. 50774.

■ 50775, 50835, 50895, 50955: INCHING



These signals go ON when using the inching of the work instructions.

For a system with one application, use signal No. 50775.



For normal inching, use signal No. OT# 1023, 1015, 1007, 999.

4 Specific I/O Signals

4.12 Specific Output Signals: Explanation

■ 50776, 50836, 50896, 50956: RETRACT



These signals go ON when using retract of the work instructions.

For a system with one application, use signal No. 50776.



For normal inching, use signal No. OT# 1024, 1016, 1008, 1000.

■ 50777, 50837, 50897, 50957: RETRY RETURN PROCESSING



These signals indicate that the retry returning is executed by the "RETRY RETURN REQUEST" (40576, 40636, 40696, 40756) signals.

For a system with one application, use signal No. 50777.

■ 50780, 50840, 50900, 50960: RESTART PROCESSING (ARC SHORTAGE)



■ 50781, 50841, 50901, 50961: RESTART PROCESSING (GAS SHORTAGE)



■ 50782, 50842, 50902, 50962: RESTART PROCESSING (WIRE SHORTAGE)



These signals indicate that restarting is executed by the "RESTART REQUEST" (40580 to 40582, 40640 to 40642, 40700 to 40702, 40760 to 40762) signals. These can be released by the "RESTART PROCESS RESET" OT# 1022, 1014, 1006, 998 signals.

For a system with one application, use signal No. 50780, 50781, or 50782.

■ 50783, 50843, 50903, 50963: RESTART RETURN PROCESSING



These signals are one of the signals related to the restarting operations and indicate that the restart returning is executed.

For a system with one application, use signal No. 50783.

■ 50784, 50844, 50904, 50964: RETRY SETTING TIME EXCEEDED



These signals indicate that the accumulated number of restart times has been reached or exceeded the set value.

For a system with one application, use signal No. 50784.

■ 50785, 50845, 50905, 50965, : ARC SHORTAGE RESTART SETTING TIMES EXCEEDED



These signals indicate that the accumulated number of arc shortage restart times has been reached or exceeded the set value.

For a system with one application, use signal No. 50785.

■ 50786, 50846, 50906, 50966: AUTOMATIC ANTI-STICKING SETTING TIMES EXCEEDED



These signals indicate that the accumulated number of automatic anti-sticking times has been reached or exceeded the set value.

For a system with one application, use signal No. 50786.

■ 50787, 50847, 50907, 50967: RETRY REPLAY MODE



These signals inform that arc retry is being executed in the replay operation mode.

For a system with one application, use signal No. 50787.

4.12.9 Signals for Handling

Signals from 50770 to 51007 are classified into four blocks and assigned to output signals that have different meanings depending on the application. Most of these outputs are used by the system so they cannot be used from the outside of the NX100. This section explains exceptional signals that are available for external use.

■ 50776, 50836, 50896, 50956: SHOCK SENSOR FUNCTION SELECT



This signal monitors the status of the shock sensor function use in the handling application.

For a system with one application, use signal No. 50776.

■ 50777, 50837, 50897, 50957: SHOCK SENSOR INPUT



These signals output the status signal to show whether the shock sensor input function is valid in the teach mode for the handling application. When concurrent I/O is the standard handling ladder, an alarm occurs by shock sensor input when these signals are ON; only a message is displayed on the programming pendant when these are OFF. "JOG" and other operations can be executed.

For a system with one application, use signal No. 50777.

■ 50780 to 50787, 50840 to 50847, 50900 to 50907, 50960 to 50967: TOOL VALVE OUTPUT



These signals are specific output signals for tool valves which are turned on/off by the instruction "HAND". When using the "HAND" instruction, connect it to the specific input section of the NIO01 board which is connected to these signals.

For a system with one manipulator, use signal No. 50780 to 50787.

4 Specific I/O Signals

4.12 Specific Output Signals: Explanation

4.12.10 Signals for Spot Welding

Signals from 50770 to 51007 are classified into four blocks and assigned to output signals for spot welding applications. Most of these inputs are used by the system so they cannot be used from the outside of the NX100. This section explains exceptional signals that are available for external use.

■ 50773, 50783, 50793, 50803: WEAR DETECTION NORMAL



These signals are turned on when the detected wear friction amount is normal after executing the wear detection with a sensor (TWC-B) by a SVGUNCL instruction.

■ 50774, 50784, 50794, 50804: WEAR DETECTION ERROR (Motor Gun)



These signals output pulses (pulse width: 500 msec) if the signal from a sensor is not turned on/off properly when executing the wear detection with the sensor.

For a system for one application, use signal No. 50774.

■ 50775, 50785, 50795, 50805: CHANGE TIP ALM (Motor Gun)



These signals output pulses (pulse width: 500 msec) if the electrode wear amount exceeds the alarm set value (parameter AxP016 and AxP017) when executing the wear detection.

For a system for one application, use signal No. 50775.

■ 50776, 50786, 50796, 50806: SVSPOT EXECUTE (Motor Gun)



These signals turn on while a SVSPOT instruction is executing in a job.

For a system for one application, use signal No. 50776.

■ 50777: WELDING ON/OFF



This signal monitors the welding on/off from the programming pendant. Use this signal when the manual spot welding in the teach mode.

■ 50780, 50790, 50800, 50810: SENSOR DETECTING



These signals are turned on when the wear detection with a sensor (TWC-B) is executing by a SVGUNCL instruction.

4.12.11 Signals for General-Purpose Applications

Signals from 50770 to 51007 are classified into four blocks and assigned to output signals that have different meanings depending on the application. Most of these outputs are used by the system so they cannot be used from the outside of the NX100. This section explains exceptional signals that are available for external use.

■ 50770, 50830, 50890, 50950: WORK START Instructions

These signals indicate work starting and wait for inputting of the “WORK START RESPONSE” (40570, 40630, 40690, 40750) signal.

For a system with one application, use signal No. 50770.

■ 50771, 50831, 50891, 50951: WORK END Instructions

These signals indicate work ending and wait for inputting of the “WORK END RESPONSE” (40571, 40631, 40691, 40751) signal.

For a system with one application, use signal No. 50771.

■ 50772, 50832, 50892, 50952: WORK CONTINUING PROHIBIT Instructions

These signals indicate whether to continue the operation when resuming, after stopping while at the operation. When the signals are ON, the operation is not continued.

For a system with one application, use signal No. 50772.

5 Internal Signal Used in Standard Ladder

5.1 Signals for Arc Welding

5 Internal Signal Used in Standard Ladder

5.1 Signals for Arc Welding

70017	70016	70015	70014	70013	70012	70011	70010
CONTROL POWER ON COMPLETED (NORMALITY ON)	SYSTEM RESERVE	SYSTEM RESERVE				START RECEIVING READY	EXT START
70027	70026	70025	70024	70023	70022	70021	70020
		REMOTE SELECT			SEQUENCE PROGRAM WAIT REQUEST	WAIT UNTIL INTRFRNC OFF	ALARM OCCUR
70037	70036	70035	70034	70033	70032	70031	70030
IN CUBE 4	IN CUBE 3	IN CUBE 2	IN CUBE 1	INTRF 4 ENTRANCE PROHIBIT	INTRF 3 ENTRANCE PROHIBIT	INTRF 2 ENTRANCE PROHIBIT	INTRF 1 ENTRANCE PROHIBIT
70047	70046	70045	70044	70043	70042	70041	70040
MOTOR STOP MEMORY	ARC OCCUR PROHIBIT	PSEUDO ARC ON	STICK DETECTION	WIRE SHORTAGE	GAS SHORTAGE	ARC SHORTAGE	ARC OCCUR CHECK
70057	70056	70055	70054	70053	70052	70051	70050
WIRE RETRACT REQUEST	WIRE INCHING REQUEST	MOTOR REVERSE ROTATION PERMIT	MOTOR FORWARD ROTATION PERMIT	MOTOR REVERSE ROTATION MEMORY	MOTOR FORWARD ROTATION MEMORY	MOTOR DIRECTION CHANGE PROHIBIT	MOTOR DIRECTION CHANGE PERMIT
70067	70066	70065	70064	70063	70062	70061	70060
ARC ANSWER ERROR (SUB)	ARC OCCUR CONDITION OK	ARC OCCUR CONDITION MODE	ARC OCCUR CONDITION CYCLE	ARC STOP	ARC ON INTERVAL	WIRE RETRACT	WIRE INCHING
70077	70076	70075	70074	70073	70072	70071	70070
STICKING (AT ON/OFF)	STICKING (AT ON)	STICKING (AT OFF)	STICKING DETECTION (AT OFF/ERROR)	STICKING CHECK REQUEST	ARC OCCRRNC MEMORY	ARC ON CONTINUE PROHIBIT	ARC OCCUR

5 Internal Signal Used in Standard Ladder
5.1 Signals for Arc Welding

70087	70086	70085	70084	70083	70082	70081	70080
STICKING CHECKED (AT ARC ANS ERROR)	ARC SHORTAGE (AT ARC ON)	AUTO STICKING RELEASE COUNTINUE	AUTO STICKING RELEASE	STICKING CHECKED	STICKING CHECK	NO STICKING	STICKING (FINAL)
70097	70096	70095	70094	70093	70092	70091	70090
RESTART RETURN MEMORY	RETRYING	RETRY COUNT	RETRY PROCES- SING	RETRY TESTED	RETRY REQUEST MEMORY	ARC ANSWER ERROR OUTPUT	ARC ANSWER ERROR (FINAL)
70107	70106	70105	70104	70103	70102	70101	70100
WIRE SHORTAGE MESSAGE CONDITION	GAS SHORTAGE MESSAGE CONDITION	ARC SHORTAGE ALARM CONDITION	RESTART INVALID	RESTARTING	RESTART MEMORY	ARC SHORTAGE RESTART MEMORY RESET	ARC SHORTAGE RESTART MEMORY
70117	70116	70115	70114	70113	70112	70111	70110
ARC SHORTAGE ALARM CONDITION WAITING 2	ARC SHORTAGE ALARM CONDITION WAITING 1	RESTART MESSAGE INVALID				WIRE SHORTAGE ALARM CONDITION	GAS SHORTAGE ALARM CONDITION
70127	70126	70125	70124	70123	70122	70121	70120
	ARC RESTART REQUEST CONDITION	OPERATION CONTINUING	ARC STOP (AT ARC SHORTAGE RESTART)	WIRE SHORTAGE MESSAGE CONDITION WAITING 2	WIRE SHORTAGE MESSAGE CONDITION WAITING 1	GAS SHORTAGE MESSAGE CONDITION WAITING 2	GAS SHORTAGE MESSAGE CONDITION WAITING 1
70137	70136	70135	70134	70133	70132	70131	70130
STICKING (MOVE CHECK)	STICKING DETECTION AT MOVING (MOVE CHECK)	NO STICKING (MOVE CHECK)	MOVE STICKING CHECK PROHIBIT	MOVE STICKING CHECKING	MOVE STICKING CHECK	TEST RUN ARC ON SELECT (OPERATION & EDIT)	TEST RUN ARC ON SELECT (MANAGEMENT)
70147	70146	70145	70144	70143	70142	70141	70140
70157	70156	70155	70154	70153	70152	70151	70150
ARC AND RELAY STICKING CONFIRM AUXILIARY	ARC CONFIRM RELAY STICKING	ARC OCCURING (STATE)	ARC SHORTAGE (ROBOT SIDE)	WELDING POWER ERROR	ARC SHORTAGE REQUEST DELAY TIME 30 msec	ARC SHORTAGE REQUEST DELAY TIME 20 msec	ARC SHORTAGE REQUEST DELAY TIME 10 msec
:							
79997	79996	79995	79994	79993	79992	79991	79990

5 Internal Signal Used in Standard Ladder

5.2 Signals for Handling

5.2 Signals for Handling

70017	70016	70015	70014	70013	70012	70011	70010
CONTROL POWER ON COMPLETED (NORMALITY ON)	SYSTEM RESERVE	SYSTEM RESERVE					EXT START

70027	70026	70025	70024	70023	70022	70021	70020
		REMOTE SELECT			EXT HOLD	WAIT UNTIL INTRFNC OFF	ALARM OCCUR

70037	70036	70035	70034	70033	70032	70031	70030
IN CUBE 4	IN CUBE 3	IN CUBE 2	IN CUBE 1	INTRF 4 ENTRANCE PROHIBIT	INTRF 3 ENTRANCE PROHIBIT	INTRF 2 ENTRANCE PROHIBIT	INTRF 1 ENTRANCE PROHIBIT

70047	70046	70045	70044	70043	70042	70041	70040
	IN CUBE 7	IN CUBE 6	IN CUBE 5		INTRF 7 ENTRANCE PROHIBIT	INTRF 6 ENTRANCE PROHIBIT	INTRF 5 ENTRANCE PROHIBIT

70057	70056	70055	70054	70053	70052	70051	70050
			AIR PRESSURE LOW INPUT	SHOCK SENSOR INPUT	WORK INST CONT PROHIBIT	WORK RUNNING	WORK INSTRUCTION

70067	70066	70065	70064	70063	70062	70061	70060
PLAY/CONT SELECT	PLAY/CONT SELECTING	PLAY/1 CYCLE SELECT	PLAY/1 CYCLE SELECTING				

:

79997	79996	79995	79994	79993	79992	79991	79990

5.3 Signals for Spot Welding

70017	70016	70015	70014	70013	70012	70011	70010
CONTROL POWER ON COMPLETED (NORMALITY ON)	SYSTEM RESERVE	SYSTEM RESERVE				START RECEIVING READY	EXT START
70027	70026	70025	70024	70023	70022	70021	70020
		REMOTE SELECT				WAITING UNTIL INTRFRNC OFF	ALARM OCCUR
70037	70036	70035	70034	70033	70032	70031	70030
IN CUBE 4	IN CUBE 3	IN CUBE 2	IN CUBE 1	INTRF 4 ENTRANCE PROHIBIT	INTRF 3 ENTRANCE PROHIBIT	INTRF 2 ENTRANCE PROHIBIT	INTRF 1 ENTRANCE PROHIBIT
70047	70046	70045	70044	70043	70042	70041	70040
						WELDING STOP INPUT	WELDING ON/OFF REQUEST
70057	70056	70055	70054	70053	70052	70051	70050
			GUN COOL WATER ERROR INPUT				TIMER COOL WATER ERROR INPUT
70067	70066	70065	70064	70063	70062	70061	70060
			AIR PRESSURE LOW ERROR INPUT				TRANS THERMO ERROR INPUT
70077	70076	70075	70074	70073	70072	70071	70070
							WELDING ON/OFF OUTPUT
70087	70086	70085	70084	70083	70082	70081	70080
				AIR PRESS LOW ALARM REQUEST	TRANS THERMO ALARM REQUEST	GUN COOL WATER ALARM REQUEST	TIMER COOL WATER ALARM REQUEST

5 Internal Signal Used in Standard Ladder
 5.3 Signals for Spot Welding

70097	70096	70095	70094	70093	70092	70091	70090
				AIR PRESS LOW MESSAGE REQUEST		GUN COOL WATER MESSAGE REQUEST	TIMER COOL WATER MESSAGE REQUEST

70107	70106	70105	70104	70103	70102	70101	70100
	SERVO AUTO OFF RESULT	SERVO AUTO OFF AUXILIARY 4	SERVO AUTO OFF AUXILIARY 3	SERVO AUTO OFF AUXILIARY 2	SERVO AUTO OFF AUXILIARY 1	INITIAL THROUGH 2	INITIAL THROUGH 1

:

79997	79996	79995	79994	79993	79992	79991	79990

5.4 Signals for General-Purpose Applications

70017	70016	70015	70014	70013	70012	70011	70010
CONTROL POWER ON COMPLETED (NORMALITY ON)	SYSTEM RESERVE	SYSTEM RESERVE				EXT START RECEIVING READY	EXT START

70027	70026	70025	70024	70023	70022	70021	70020
		REMOTE SELECT				WAIT UNTIL INTRFRNC OFF	ALARM OCCUR

70037	70036	70035	70034	70033	70032	70031	70030
IN CUBE 4	IN CUBE 3	IN CUBE 2	IN CUBE 1	INTRF 4 ENTRANCE PROHIBIT	INTRF 3 ENTRANCE PROHIBIT	INTRF 2 ENTRANCE PROHIBIT	INTRF 1 ENTRANCE PROHIBIT

70047	70046	70045	70044	70043	70042	70041	70040
				WORK PROHIBIT	WORK INSTRUCTION CONTINUE PROHIBIT	WORK OPERATING	WORK INSTRUCTION

70057	70056	70055	70054	70053	70052	70051	70050

:

79997	79996	79995	79994	79993	79992	79991	79990

6 Internal Control Status Signals

6.1 Internal Control Status Signals

* : NC contact

80017	80016	80015	80014	80013	80012	80011	80010
SVON	START	HOLD		TEACH	PLAY	REMOTE	EDIT_LOCK

EDIT_LOCK	Editing Prohibit
REMOTE	Remote Mode Select
PLAY	Play Mode Select
TEACH	Teach Mode Select
*HOLD	Hold (Programming Pendant)
START	Operation Start (Programming Pendant)
SVON	Servo On (Programming Pendant)

80027	80026	80025	80024	80023	80022	80021	80020
PBESP	PPESP	EXESP	ERRCPU	SAFF			

*SAFF	Safety Plug Input
*ERRCPU	NCP01 CPU Error (Emergency Stop)
*EXESP	External Emergency Stop
*PPESP	Programming Pendant Emergency Stop
*PBESP	NX100 Door Emergency Stop

80037	80036	80035	80034	80033	80032	80031	80030
EXSVON	EXDSW	EXHOLD	DSW	SVONRDY1	MAINTE	SVONRDY0	

SVONRDY0 Servo ON Condition 1
 MAINTE Maintenance Input
 SVONRDY1 Servo ON Condition 2
 DSW Deadman Switch Input
 *EXHOLD External Hold
 EXDSW External Deadman Switch Input
 EXSVON External Servo On

80047	80046	80045	80044	80043	80042	80041	80040
FST	SSP					SAFSPD1	SAFSPD2

SAFSPD2 Safe Speed 2
 SAFSPD1 Safe Speed 1
 SSP Safe Speed Mode Select
 FST Full-speed Test

80057	80056	80055	80054	80053	80052	80051	80050
						EX24VU_OK	24VU_OK

24VU_OK 24V OK
 EX24VU_OK External 24V OK

6 Internal Control Status Signals

6.1 Internal Control Status Signals

80067	80066	80065	80064	80063	80062	80061	80060
OT	EXOT	SHOCK1	ERRSVCPU		FUCUT	ON-EN	SHOCK2

*SHOCK2	Shock Sensor Operation Hold
*ON-EN	Servo On Enabled
*FUCUT	Blake Fuse Blown
*ERRSVCPU	Servo CPU Error
*SHOCK1	Shock Sensor Operation Emergency Stop
*EXOT	Ex-Axis Over Travel
*OT	Over Travel

80077	80076	80075	80074	80073	80072	80071	80070
				CPDIN4	CPDIN3	CPDIN2	CPDIN1

CPDIN1 (CPRIN1)	Direct In (System) 1
CPDIN2 (CPRIN2)	Direct In (System) 2
CPDIN3 (CPRIN3)	Direct In (System) 3
CPDIN4 (CPRIN4)	Direct In (System) 4

80087	80086	80085	80084	80083	80082	80081	80080
			AXDIN5	AXDIN4	AXDIN3	AXDIN2	AXDIN1

AXDIN1 (RIN1)	Direct In (Servo) 1
AXDIN2 (RIN2)	Direct In (Servo) 2
AXDIN3 (RIN3)	Direct In (Servo) 3
AXDIN4 (RIN4)	Direct In (Servo) 4
AXDIN5 (RIN5)	Direct In (Servo) 5

80097	80096	80095	80094	80093	80092	80091	80090

⋮

80647	80646	80645	80644	80643	80642	80641	80640

6.1.1 Internal Control Status Signal (Monitor)

The following symbols are used in the explanation to represent the signal conditions.



The signal takes effect while it is in the on state.



The rising edge is detected as the signal.

■ 80010: EDITING PROHIBITION



This signal indicates the operating status of the [EDIT LOCK] key.

■ 80011 to 80013: MODE SELECTION



These signals indicate the status of the mode key of the programming pendant.

■ 80015: *PROGRAMMING PENDANT PANEL HOLD



This signal indicates the operating status of the [START] key on the programming pendant.

■ 80016: OPERATION START



This signal indicates the operating status of the [START] key on the programming pendant.

■ 80017: SERVO POWER ON



This signal indicates the operating status of the [SERVO POWER] key on the programming pendant.

6 Internal Control Status Signals

6.1 Internal Control Status Signals

■ 80023: *SAFETY PLUG INPUT



This signal turns off when the safety guard input signal, connected to the specific input terminal block, operates.

For the connection, refer to “12.3.2 Units and Circuit Boards in the CPU Unit ” of the NX100 Instructions.

■ 80024: *NCP01 CPU ERROR



This signal turns off when the servo turns off in the system (NCP01 CPU).

■ 80025: *EXTERNAL EMERGENCY STOP



This signal is OFF when the emergency stop signal, connected to the specific input terminal block, is operating. For the connection, refer to the “12.3.2 Units and Circuit Boards in the CPU Unit” of the NX100 Instructions.

■ 80026: *PROGRAMMING PENDANT EMERGENCY STOP



This signal is OFF when the emergency stop on the programming pendant is operating.

■ 80027: * NX100 DOOR EMERGENCY STOP



This signal is OFF when the emergency stop on the upper part of the NX100 door is operating.

■ 80031: SERVO ON CONDITION 1



This signal turns on when the following signals satisfy the conditions for servo ON status. When this signal turns off while the servo is ON, the servo power supply is shut down.

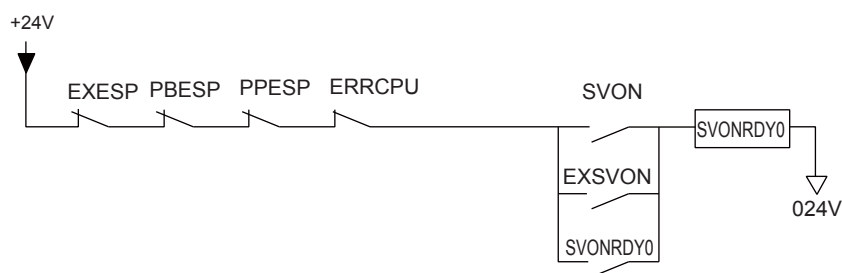

■ 80032: MAINTENANCE INPUT



This signal indicates the operation status of the external maintenance input signal.

This signal is input from the specific input terminal block.

For the connection, refer to “12.3.2 Units and Circuit Boards in the CPU Unit” of the NX100 Instructions.

■ 80033: SERVO ON CONDITION 2



This signal turns on when the following signals satisfy the conditions for servo ON status. When this signal turns off while the servo is ON, the servo power supply is shut down.

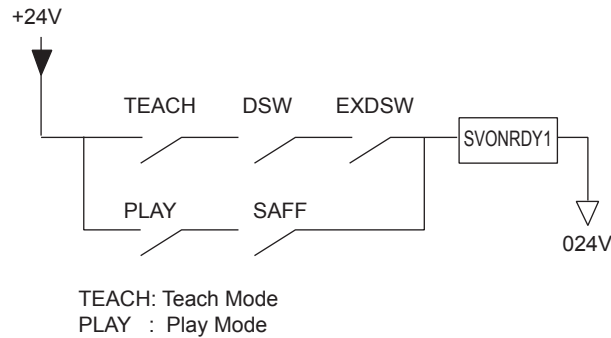

■ 80034: DEADMAN SWITCH INPUT



This signal indicates the operating status of deadman switch input signal. This signal turns on by holding the deadman switch and turns off by holding longer until it clicks.

■ 80035: *EXTERNAL HOLD



This signal indicates the operation status of the hold signal from the outside. The signal is input from the specific input terminal block. For the connection, refer to the “12.3.2 Units and Circuit Boards in the CPU Unit” of the NX100 Instructions.

■ 80036: EXTERNAL DEADMAN SWITCH INPUT



This signal indicates the operating status of the external deadman switch input signal.

■ 80037: EXTERNAL SERVO ON INPUT



This signal is ON when the servo power instruction is input from the outside. The signal is input from the specific input terminal block. For the connection, refer to the “12.3.2 Units and Circuit Boards in the CPU Unit” of the NX100 Instructions.

■ 80040: SAFE SPEED 2



This signal turns on in the safe speed 2 condition.

■ 80041: SAFE SPEED 1



This signal turns on in the safe speed 1 condition.

■ 80046: SAFE SPEED MODE SELECT



This signal is ON either in the safe speed 1 or the safe speed 2 condition.

6 Internal Control Status Signals

6.1 Internal Control Status Signals

■ 80047: FULL-SPEED TEST



This signal is ON when the safe speed limit is released.

■ 80050: 24V OK



This signal is ON when 24V power for I/O is supplied normally. For the connection of I/O power supply, refer to the “12.3.2 Units and Circuit Boards in the CPU Unit” of the NX100 Instructions.

■ 80051: EXTERNAL 24V OK



This signal is ON when 24V external power for I/O is supplied normally. For the connection of I/O power supply, refer to the “12.3.2 Units and Circuit Boards in the CPU Unit” of the NX100 Instructions.

■ 80060: *SHOCK SENSOR OPERATION HOLD



This signal indicates the detecting status of the shock sensor operation detecting circuit. This signal is input from the NIO01 board. This signal is valid when “HOLD” is set for the shock sensor stop designation in the overrun and shock sensor release window.

■ 80061: *SERVO ON ENABLED



This signal indicates the detecting status of servo ON enabled. This signal is input from the NIO01 board.

■ 80062: *BRAKE FUSE BLOWN-OFF



This signal turns off when the fuse of the brake excitation circuit is blown off.

■ 80064: *SERVO CPU ERROR



This signal turns off when an error is detected in the servo system (AXA01 CPU).

■ 80065: *SHOCK SENSOR OPERATION EMERGENCY STOP



This signal indicates the detecting status of the shock sensor operation detecting circuit. This signal is input from the NIO01 board. This signal is valid when “EMERGENCY STOP” is set for the shock sensor stop designation in the overrun and shock sensor release window.

■ 80066: *EXTERNAL AXIS OVERTRAVEL



This signal turns off when the external axis overrun LS operates. This signal is input from the NIO01 board.

■ 80067: *OVERTRAVEL

This signal turns off when the robot axis overrun LS operates.

■ 80070 to 80073: DIRECT IN (SYSTEM) 1 to 4

These signals indicate the status of direct in (system) input signals. The signals are input from the specific input terminal block.

■ 80080 to 80084: DIRECT IN (SERVO) 1 to 5

These signals indicate the status of direct in (servo) input signals. The signals are input from the specific input terminal block.

7 Pseudo Input Signals

The following symbols are used in the explanation to represent the signal conditions.



The signal takes effect while it is in the on state.



The rising edge is detected as the signal.

7.1 Pseudo Input Signals

■ 82014 to 82016: REMOTE FUNCTION SELECTION



The pseudo input signal window allows to set whether the I/O, commands, or programming pendant is used at the remote mode selection.

These signals indicate the status set in the pseudo input signal window as shown below.
(0:OFF 1:ON)

82014	IO	0:Used	1:Not Used
82015	Command	0:Not Used	1:Used
82016	Programming Pendant	0:Used	1:Not Used

■ 82020 to 82027: SIGNAL SELECT STATUS (SPOT WELDING)



The pseudo input signal window allows to set the use of the signals for the spot welding. The signals indicate the setting status in the pseudo input signal window. If the setting is ON, the signals for the spot welding are assigned. If the setting is OFF, the general output signals are assigned.

The status is as follows;

		(0:OFF 1:ON)	
82020	TIMER COOLING WATER ERROR INPUT	0:Not Used	1:Used
82021	GUN COOLING WATER ERROR INPUT	0:Not Used	1:Used
82022	TRANS. THERMO. ERROR INPUT	0:Not Used	1:Used
82023	AIR PRESSURE LOWERED INPUT	0:Not Used	1:Used
82024	WELDING ON/OFF OUTPUT	0:Not Used	1:Used
82025	SHUT OFF VALVE CONTROL	0:Not Used	1:Used
82026	ENERGY-SAVING MODE	0:Invalid	1:Valid
82027	STAND ALONE MODE	0:Invalid	1:Valid

8 Network I/O Signals

Network input signals are related to optional network functions. For the detailed information, refer to the operator's manual regarding each network function.

9 Interface Panel Signals

Interface panel signals are related to the optional interface panel functions. For details, refer to "NX100 OPTIONS INSTRUCTIONS FOR INTERFACE PANEL FUNCTION" (149648-18CD).

10 I/O Except Concurrent I/O

The following signal is connected directly to the manipulator control section without passing through the concurrent I/O.

Adequate care should be taken for switch setting and method of connection when using this signal.

10.1 Hardware Specific Input



CAUTION

- Before use, remove any jumper leads from the specific input signals.

Failure to observe this instruction may result in the malfunction leading to injury or damage to the equipment.

10 I/O Except Concurrent I/O
 10.1 Hardware Specific Input

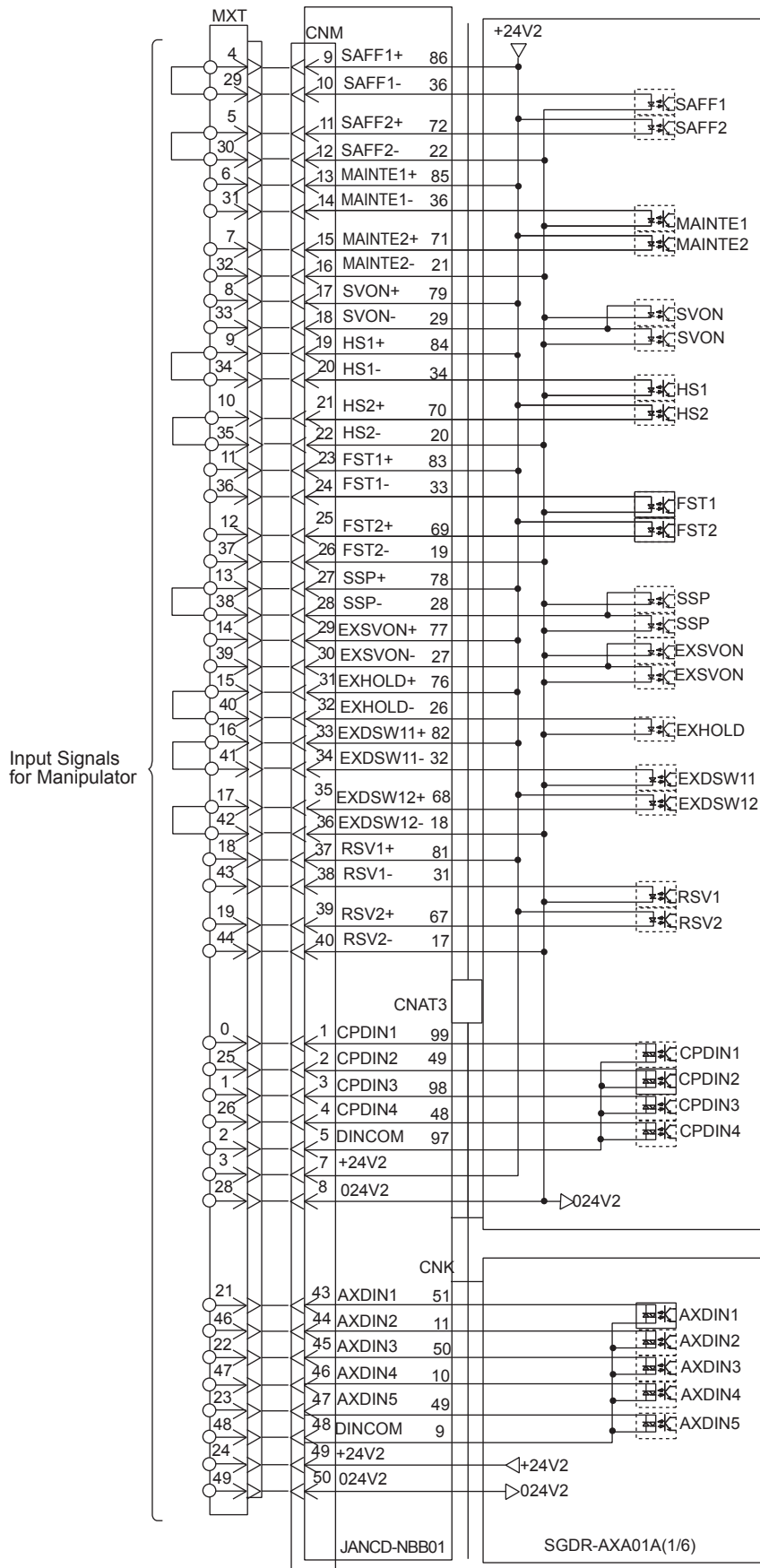

Connection of Specific Inputs



CAUTION

- Use the "MAINTE" (Maintenance) input with normally open circuit.
- Use the switch which has the key for "MAINTE" input. The system manager is responsible for storage of the key.
- Any deadman switch is invalid at the "MAINTE" input.

10.2 I/O Except Concurrent I/O: Explanation

■ EXESP: FOR EXTERNAL EMERGENCY STOP



This signal allows to use the emergency stop switch of an external operation equipment. When this signal is input, the servo power goes OFF, and the job execution is stopped. The servo power cannot be turned on while this signal is being input. This function becomes invalid by connecting the jumper wire.

■ EXHOLD: FOR EXTERNAL HOLD



This signal allows to use the hold switch of an external operation equipment. When this signal is input, the job execution stops. The start and axis functions cannot be used while this signal is being input. This function becomes invalid by connecting the jumper wire.

■ SAFF: FOR SAFETY PLUG



This signal turns off the servo power when the door of the safeguard is open. Connect interlock signals such as a safety plug installed in the safeguard door. Install an interlock signal such as safety plugs in door of the safeguard. When the interlock signal is input, the servo power goes OFF, and the servo power cannot be turned on. However, this signal is invalid in the teach mode.

■ EXSVON: FOR EXTERNAL SERVO ON



This signal allows to turn on the servo power. Use the signal to turn on the servo power by external equipment. Apart from this signal, the external servo on signal as the specific input (40045) is provided. Make this signal invalid by connecting the jumper wire before using this signal.

For safer use of the robot, use of this signal (EXSVON) which has no intervention of ladders (software) is recommended.

■ CPDIN1 to 4: FOR DIRECT IN (SYSTEM) INPUT SIGNAL 1 to 4



This signal can be used in conjunction with the search function.

10 I/O Except Concurrent I/O

10.2 I/O Except Concurrent I/O: Explanation

■ AXDIN1 to 5: FOR DIRECT IN (SERVO) INPUT SIGNAL 1 to 5



This signal can be used in conjunction with the search function.

■ MAINTE: MAINTENANCE INPUT SIGNAL



If the signal input circuit is short-circuited, the Enable switch (DSW) and the Safety Plug are disabled.

Usually, use the system with this signal circuit open (nothing connected).

If the circuit for this signal must be used for an unavoidable reason, be sure to use a switch with a key that is **kept under the care of the system manager**.

11 Register

11.1 Common Usage for All Applications

11.1.1 General Register

M009	M008	M007	M006	M005	M004	M003	M002	M001	M000

M019	M018	M017	M016	M015	M014	M013	M012	M011	M010

M029	M028	M027	M026	M025	M024	M023	M022	M021	M020

M039	M038	M037	M036	M035	M034	M033	M032	M031	M030

M049	M048	M047	M046	M045	M044	M043	M042	M041	M040

M059	M058	M057	M056	M055	M054	M053	M052	M051	M050

M069	M068	M067	M066	M065	M064	M063	M062	M061	M060

:
:

M209	M208	M207	M206	M205	M204	M203	M202	M201	M200

M219	M218	M217	M216	M215	M214	M213	M212	M211	M210
SYSTEM RESERVE				STIKICNG RELEASE (ARITH)	WIRE INCHING REQUEST TMR	WIRE RETRACT REQUEST TMR	WELDING POWER ERROR TMR	ARC SHORTAGE (ROBOT SIDE) TMR	ARC CONFIRM RELAY STICKING TMR

11 Register

11.1 Common Usage for All Applications

M269	M268	M267	M266	M265	M264	M263	M262	M261	M260
ANALOG OUTPUT 10	ANALOG OUTPUT 9	ANALOG OUTPUT 8	ANALOG OUTPUT 7	ANALOG OUTPUT 6	ANALOG OUTPUT 5	ANALOG OUTPUT 4	ANALOG OUTPUT 3	ANALOG OUTPUT 2	ANALOG OUTPUT 1

M279	M278	M277	M276	M275	M274	M273	M272	M271	M270
ANALOG OUTPUT 20	ANALOG OUTPUT 19	ANALOG OUTPUT 18	ANALOG OUTPUT 17	ANALOG OUTPUT 16	ANALOG OUTPUT 15	ANALOG OUTPUT 14	ANALOG OUTPUT 13	ANALOG OUTPUT 12	ANALOG OUTPUT 11

M289	M288	M287	M286	M285	M284	M283	M282	M281	M280
ANALOG OUTPUT 30	ANALOG OUTPUT 29	ANALOG OUTPUT 28	ANALOG OUTPUT 27	ANALOG OUTPUT 26	ANALOG OUTPUT 25	ANALOG OUTPUT 24	ANALOG OUTPUT 23	ANALOG OUTPUT 22	ANALOG OUTPUT 21

M299	M298	M297	M296	M295	M294	M293	M292	M291	M290
ANALOG OUTPUT 40	ANALOG OUTPUT 39	ANALOG OUTPUT 38	ANALOG OUTPUT 37	ANALOG OUTPUT 36	ANALOG OUTPUT 35	ANALOG OUTPUT 34	ANALOG OUTPUT 33	ANALOG OUTPUT 32	ANALOG OUTPUT 31

11.1.2 System Register

M309	M308	M307	M306	M305	M304	M303	M302	M301	M300
ANALOG INPUT 10	ANALOG INPUT 9	ANALOG INPUT 8	ANALOG INPUT 7	ANALOG INPUT 6	ANALOG INPUT 5	ANALOG INPUT 4	ANALOG INPUT 3	ANALOG INPUT 2	ANALOG INPUT 1

M319	M318	M317	M316	M315	M314	M313	M312	M311	M310
ANALOG INPUT 20	ANALOG INPUT 19	ANALOG INPUT 18	ANALOG INPUT 17	ANALOG INPUT 16	ANALOG INPUT 15	ANALOG INPUT 14	ANALOG INPUT 13	ANALOG INPUT 12	ANALOG INPUT 11

M329	M328	M327	M326	M325	M324	M323	M322	M321	M320
ANALOG INPUT 30	ANALOG INPUT 29	ANALOG INPUT 28	ANALOG INPUT 27	ANALOG INPUT 26	ANALOG INPUT 25	ANALOG INPUT 24	ANALOG INPUT 23	ANALOG INPUT 22	ANALOG INPUT 21

M339	M338	M337	M336	M335	M334	M333	M332	M331	M330
ANALOG INPUT 40	ANALOG INPUT 39	ANALOG INPUT 38	ANALOG INPUT 37	ANALOG INPUT 36	ANALOG INPUT 35	ANALOG INPUT 34	ANALOG INPUT 33	ANALOG INPUT 32	ANALOG INPUT 31

M349	M348	M347	M346	M345	M344	M343	M342	M341	M340
			ERROR DATA H	ERROR DATA L	ERROR CODE		ALARM DATA H	ALARM DATA L	ALARM CODE

M359	M358	M357	M356	M355	M354	M353	M352	M351	M350

M369	M368	M367	M366	M365	M364	M363	M362	M361	M360

M379	M378	M377	M376	M375	M374	M373	M372	M371	M370

M389	M388	M387	M386	M385	M384	M383	M382	M381	M380

M399	M398	M397	M396	M395	M394	M393	M392	M391	M390

M409	M408	M407	M406	M405	M404	M403	M402	M401	M400

11 Register

11.1 Common Usage for All Applications

M419	M418	M417	M416	M415	M414	M413	M412	M411	M410

:
:

M459	M458	M457	M456	M455	M454	M453	M452	M451	M450

11.2 Arc Welding

M229	M228	M227	M226	M225	M224	M223	M222	M221	M220

M239	M238	M237	M236	M235	M234	M233	M232	M231	M230

M249	M248	M247	M246	M245	M244	M243	M242	M241	M240

M259	M258	M257	M256	M255	M254	M253	M252	M251	M250
MOVE STICKING CHECK (PRESENT VALUE)	NO MOVE STICKING CHECK	STICKING RELEASE (PRESENT VALUE)	RESTART (PRESENT VALUE)	RETRY (PRESENT VALUE)	WIRE OPERATION SWITCH (PRESENT VALUE)	ANTI STICKING (PRESENT VALUE)	NO STICKING CHECK (PRESENT VALUE)	STICKING CHECK (PRESENT VALUE)	ARC ANSWR ERROR (PRESENT VALUE)

M469	M468	M467	M466	M465	M464	M463	M462	M461	M460
		STICKING RELEASE (3 TIMES)	RESTART (ONCE)	RETRY (ONCE)	WIRE OPERATION SWITCH (0.5 SEC)	ANTI STICKING (0.3 SEC)	NO STICKING CHECK (0.2 SEC)	STICKING CHECK (1.0 SEC)	ARC ANSWR ERROR (3.0 SEC)

M479	M478	M477	M476	M475	M474	M473	M472	M471	M470

M489	M488	M487	M486	M485	M484	M483	M482	M481	M480

M499	M498	M497	M496	M495	M494	M493	M492	M491	M490

11 Register
11.3 Handling

11.3 Handling

M229	M228	M227	M226	M225	M224	M223	M222	M221	M220

M239	M238	M237	M236	M235	M234	M233	M232	M231	M230

M249	M248	M247	M246	M245	M244	M243	M242	M241	M240

M259	M258	M257	M256	M255	M254	M253	M252	M251	M250

M469	M468	M467	M466	M465	M464	M463	M462	M461	M460

M479	M478	M477	M476	M475	M474	M473	M472	M471	M470

M489	M488	M487	M486	M485	M484	M483	M482	M481	M480

M499	M498	M497	M496	M495	M494	M493	M492	M491	M490

11.4 General Purposes

M229	M228	M227	M226	M225	M224	M223	M222	M221	M220

M239	M238	M237	M236	M235	M234	M233	M232	M231	M230

M249	M248	M247	M246	M245	M244	M243	M242	M241	M240

M259	M258	M257	M256	M255	M254	M253	M252	M251	M250

M469	M468	M467	M466	M465	M464	M463	M462	M461	M460

M479	M478	M477	M476	M475	M474	M473	M472	M471	M470

M489	M488	M487	M486	M485	M484	M483	M482	M481	M480

M499	M498	M497	M496	M495	M494	M493	M492	M491	M490

11 Register
11.5 Spot Welding

11.5 Spot Welding

M229	M228	M227	M226	M225	M224	M223	M222	M221	M220

M239	M238	M237	M236	M235	M234	M233	M232	M231	M230

M249	M248	M247	M246	M245	M244	M243	M242	M241	M240

M259	M258	M257	M256	M255	M254	M253	M252	M251	M250
							AIR PRESSURE LOWERED (PRESENT VALUE)	GUN COOL ERROR (PRESENT VALUE)	TIMER COOL ERROR (PRESENT VALUE)

M469	M468	M467	M466	M465	M464	M463	M462	M461	M460
							AIR PRESSURE LOWERED (3.0 SEC)	GUN COOL ERROR (3.0 SEC)	TIMER COOL ERROR (3.0 SEC)

M479	M478	M477	M476	M475	M474	M473	M472	M471	M470

M489	M488	M487	M486	M485	M484	M483	M482	M481	M480

M499	M498	M497	M496	M495	M494	M493	M492	M491	M490

12 Standard Ladder Program

12.1 List of Usable Instructions

The following table shows a list of usable instructions in concurrent I/O.











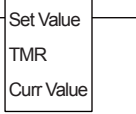
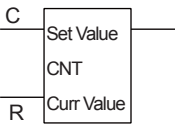
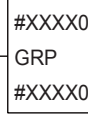



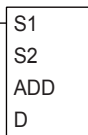
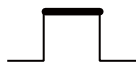
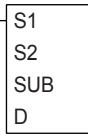

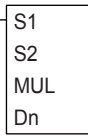

In the instruction, there are two kinds of instructions, the one which uses the memory of one step and the other which uses the memory of two steps.

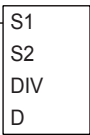
Instruction	Symbol	Function	Format	Remarks
STR		Logic line starting Temporary storing of intermediate result in logical operation Relay No. #XXXXX	STR #XXXXX	1 Step Instruction
STR-NOT		NC contact used to start the logic line Temporary storing of intermediate result in logical operation Relay No. #XXXXX	STR-NOT #XXXXX	1 Step Instruction
AND		Logical AND Relay No. #XXXXX	AND #XXXXX	1 Step Instruction
AND-NOT		Logical AND negation Relay No. #XXXXX	AND-NOT #XXXXX	1 Step Instruction
OR		Logical OR Relay No. #XXXXX	OR #XXXXX	1 Step Instruction
OR-NOT		Logical OR negation Relay No. #XXXXX	OR-NOT #XXXXX	1 Step Instruction
AND-STR		Logical AND for intermediate are result	AND-STR	1 Step Instruction
OR-STR		Logical OR for intermediate are result	OR-STR	1 Step Instruction
OUT		External or internal output Relay No. #XXXXX	OUT #XXXXX	1 Step Instruction
PART		User/System Identification (Not displayed on the programming pendant)	PART N	1 Step Instruction
END		Program end (Not displayed on the programming pendant)	END	1 Step Instruction

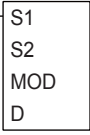
12 Standard Ladder Program

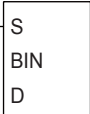

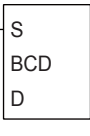
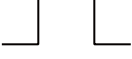
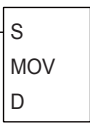



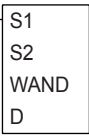

12.1 List of Usable Instructions

Instruction	Symbol	Function	Format	Remarks
TMR		ON-delay time (100ms) Set Value (S) • Decimal (0-65535) • Register (M000-M499) Curr value (D) • Register (M000-M259)	TMR D,S	2 Steps Instruction
CNT		Subtract counter Set value (S) • Decimal (0-65535) • Register (M000-M499) Curr value (D) • Register (M000-M259)	CNT D,S	2 Steps Instruction
GSTR		Transmission of batch con- tents of 1 group (8 bits) Relay No. #XXXX0	GSTR #XXXX0	1 Step Instruction
GOUT			GOUT #XXXX0	1 Step Instruction
PLS		Rising up pulse output Relay No. #XXXXX	PLS #XXXXX	1 Step Instruction Exe Condition 
PLF		Rising down pulse output Relay No. #XXXXX	PLF #XXXXX	1 Step Instruction Exe Condition 
ADD	 D←S1+S2 Arith Flag: Carry=0/1; Zero=0/1; (Error=0)	Add 16 bits unsigned binary data (0-65535) S1, S2: Source • Decimal (0-65535) • Register (M000-M499) D: Destination • Register (M000-M299)	ADD S1,S2,D	2 Steps Instruction Exe Condition 
SUB	 D←S1-S2 Arith Flag: Carry=0/1; Zero=0/1; (Error=0)	Subtract 16 bits unsigned binary data (0-65535) S1, S2: Source • Decimal (0-65535) • Register (M000-M499) D: Destination • Register (M000-M299)	SUB S1,S2,D	2 Steps Instruction Exe Condition 
MUL	 Dn+1,Dn←S1xS2 Arith Flag: (Carry=0); (Zero=0); (Error=0)	Multiply 16 bits unsigned binary data (0-65535) S1, S2: Source • Decimal (0-65535) • Register (M000-M499) Dn, Dn+1: Destination Dn: Low data storing register Dn+1: High data storing register • Register (M000-M299)	MUL S1,S2,D	2 Steps Instruction Exe Condition 

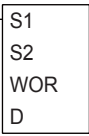
Instruction	Symbol	Function	Format	Remarks
DIV	 <p>D(Quotient)\leftarrowS1/S2 Arith Flag: (Carry=0); (Zero=0); Error=0/1</p>	Divide 16 bits unsigned binary data (0-65535) S1, S2: Source <ul style="list-style-type: none"> • Decimal (0-65535) • Register (M000-M499) D: Destination <ul style="list-style-type: none"> • Register (M000-M299) 	DIV S1,S2,D	2 Steps Instruction Exe Condition 
MOD	 <p>D(Modulus)\leftarrowS1/S2 Arith Flag: (Carry=0); (Zero=0); Error=0/1</p>	Modules of 16 bits unsigned binary data (0-65535) S1, S2: Source <ul style="list-style-type: none"> • Decimal (0-65535) • Register (M000-M499) D: Destination <ul style="list-style-type: none"> • Register (M000-M299) 	MOD S1,S2,D	2 Steps Instruction Exe Condition 
BIN	 <p>D\leftarrowS Arith Flag: Carry=0/1; (Zero=0); Error=0/1</p>	Convert 8/16 bits data from BCD to BIN S: Source <ul style="list-style-type: none"> • Register (M000-M499) • Relay No. (byte) #XXXX0 • Relay No. (word) W#XXXX0 D: Destination <ul style="list-style-type: none"> • Register (M000-M299) • Relay No. (byte) #XXXX0 • Relay No. (word) W#XXXX0 	BIN S,D	2 Steps Instruction Exe Condition 
BCD	 <p>D\leftarrowS Arith Flag: Carry=0/1; (Zero=0); Error=0/1</p>	Convert 8/16 bits data from BIN to BCD S: Source <ul style="list-style-type: none"> • Register (M000-M499) • Relay No. (byte) #XXXX0 • Relay No. (word) W#XXXX0 D: Destination <ul style="list-style-type: none"> • Register (M000-M299) • Relay No. (byte) #XXXX0 • Relay No. (word) W#XXXX0 	BCD S,D	2 Steps Instruction Exe Condition 
MOV	 <p>D\leftarrowS</p>	Transmit 8/16 bits data S: Source <ul style="list-style-type: none"> • Decimal (0-65535) • Register (M000-M499) • Relay No. (byte) #XXXX0 • Relay No. (word) W#XXXX0 D: Destination <ul style="list-style-type: none"> • Register (M000-M299) • Relay No. (byte) #XXXX0 • Relay No. (word) W#XXXX0 	MOV S,D	2 Steps Instruction Exe Condition 

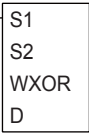
12 Standard Ladder Program

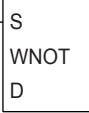
12.1 List of Usable Instructions

Instruction	Symbol	Function	Format	Remarks
WAND	 $D \leftarrow S1 \cap S2$	Logical AND of 8/16 bits data S1, S2: Source <ul style="list-style-type: none"> • Decimal (0-65535) • Register (M000-M499) • Relay No. (byte) #XXXX0 • Relay No. (word) W#XXXX0 D: Destination <ul style="list-style-type: none"> • Register (M000-M299) • Relay No. (byte) #XXXX0 • Relay No. (word) W#XXXX0 	WAND S1,S2,D	2 Steps Instruction Exe Condition 
WOR	 $D \leftarrow S1 \cup S2$	Logical OR of 8/16 bits data S1, S2: Source <ul style="list-style-type: none"> • Decimal (0-65535) • Register (M000-M499) • Relay No. (byte) W#XXXX0 • Relay No. (word) W#XXXX0 D: Destination <ul style="list-style-type: none"> • Register (M000-M299) • Relay No. (byte) #XXXX0 • Relay No. (word) W#XXXX0 	WOR S1,S2,D	2 Steps Instruction Exe Condition 
WXOR	 $D \leftarrow (S1 \cup S2) \cup \overline{(S1 \cap S2)}$	Exclusive OR of 8/16 bits data S1, S2: Source <ul style="list-style-type: none"> • Decimal (0-65535) • Register (M000-M499) • Relay No. (byte) #XXXX0 • Relay No. (word) W#XXXX0 D: Destination <ul style="list-style-type: none"> • Register (M000-M299) • Relay No. (byte) #XXXX0 • Relay No. (word) W#XXXX0 	WXOR S1,S2,D	2 Steps Instruction Exe Condition 
WNOT	 $D \leftarrow \bar{S}$	Logical NOT of 8/16 bits data S: Source <ul style="list-style-type: none"> • Decimal (0-65535) • Register (M000-M499) • Relay No. (byte) #XXXX0 • Relay No. (word) W#XXXX0 D: Destination <ul style="list-style-type: none"> • Register (M000-M299) • Relay No. (byte) #XXXX0 • Relay No. (word) W#XXXX0 	WNOT S,D	2 Steps Instruction Exe Condition 

Instruction	Symbol	Function	Format	Remarks
SHL	<p>Arith Flag: Carry=0/1; (Zero=0); (Error=0)</p>	<p>Left shift of 8/16 bits data</p> <p>S: Source</p> <ul style="list-style-type: none"> • Decimal (0-65535) • Register (M000-M499) • Relay No. (byte) #XXX0 • Relay No. (word) W#XXXX0 <p>n: Shift count</p> <ul style="list-style-type: none"> • Decimal (0-16) <p>D: Destination</p> <ul style="list-style-type: none"> • Register (M000-M299) • Relay No. (byte) #XXX0 • Relay No. (word) W#XXXX0 	SHL S,n,D	<p>2 Steps Instruction</p> <p>Exe Condition</p>
SHR	<p>Arith Flag: Carry=0/1; (Zero=0); (Error=0)</p>	<p>Right shift of 8/16 bits data</p> <p>S: Source</p> <ul style="list-style-type: none"> • Decimal (0-65535) • Register (M000-M499) • Relay No. (byte) #XXX0 • Relay No. (word) W#XXXX0 <p>n: Shift count</p> <ul style="list-style-type: none"> • Decimal (0-16) <p>D: Destination</p> <ul style="list-style-type: none"> • Register (M000-M299) • Relay No. (byte) #XXX0 • Relay No. (word) W#XXXX0 	SHR S,n,D	<p>2 Steps Instruction</p> <p>Exe Condition</p>
ROL	<p>(Note) Carry flag is not included in rotation. Arith Flag: Carry=0/1; (Zero=0); (Error=0)</p>	<p>Left rotation of 8/16 bits data</p> <p>S: Source</p> <ul style="list-style-type: none"> • Decimal (0-65535) • Register (M000-M499) • Relay No. (byte) #XXX0 • Relay No. (word) W#XXXX0 <p>n: Rotation count</p> <ul style="list-style-type: none"> • Decimal (0-16) <p>D: Destination</p> <ul style="list-style-type: none"> • Register (M000-M299) • Relay No. (byte) #XXX0 • Relay No. (word) W#XXXX0 	ROL S,n,D	<p>2 Steps Instruction</p> <p>Exe Condition</p>
ROR	<p>(Note) Carry flag is not included in rotation. Arith Flag: Carry=0/1; (Zero=0); (Error=0)</p>	<p>Right rotation of 8/16 bits data</p> <p>S: Source</p> <ul style="list-style-type: none"> • Decimal (0-65535) • Register (M000-M499) • Relay No. (byte) #XXX0 • Relay No. (word) W#XXXX0 <p>n: Rotation count</p> <ul style="list-style-type: none"> • Decimal (0-16) <p>D: Destination</p> <ul style="list-style-type: none"> • Register (M000-M299) • Relay No. (byte) #XXX0 • Relay No. (word) W#XXXX0 	ROR S,n,D	<p>2 Steps Instruction</p> <p>Exe Condition</p>

#XXXXX: Relay No., MXXX: Register Number, YYYY: Numerical Value (0-65535), N: Numerical Value (1-2)

12.2 Instruction Description

NOTE

- Output to each single relay is only once. It is unable to use multiple times of output to the same relay.
- The numbers of the output relays are limited to 0XXXX, 3XXXX, 4XXXX, and 7XXXX.
- It is able to register up to 260 TMR/CNT instructions and operation instructions that can use registers.
- It is unable to use the multiple times outputs of the registers that were used as current values of TMR/CNT instructions. However, it is able to use the multiple times outputs of the registers that were used as the destination registers of arithmetic instructions.

■ STR Instruction

Format

STR #XXXXX
#XXXXX: Relay No.

Function

Operates as a Normal Open at the beginning of logical line.
Stores temporarily the preliminary result of the logic operation.

Ladder Program Example

<Ladder Diagram>



< Program >

```
STR #70010
OUT #70100
```

■ STR-NOT Instruction

Format

STR-NOT #XXXXX
#XXXXX: Relay No.

Function

Operates as a Normal Close at the beginning of logical line.
Stores temporarily the preliminary result of the logic operation.

Ladder Program Example

<Ladder Diagram>



< Program>

```
STR-NOT #70010
OUT      #70100
```

■ AND Instruction

Format

AND #XXXXX
#XXXXX: Relay No.

Function

Performs logical AND operation.

Ladder Program Example

<Ladder Diagram>

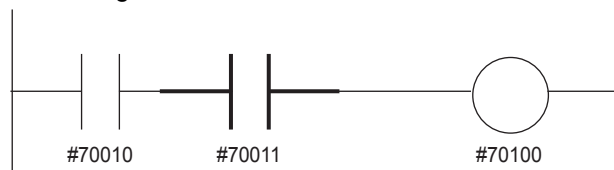

< Program>

```
STR #70010
AND #70011
OUT #70100
```

■ AND-NOT Instruction

Format

AND-NOT #XXXXX
#XXXXX: Relay No.

Function

Performs logical AND negation operation.

Ladder Program Example

<Ladder Diagram>



< Program>

```
STR      #70010
AND-NOT #70011
OUT      #70100
```

12 Standard Ladder Program

12.2 Instruction Description

■ OR Instruction

Format

OR #XXXXX
 #XXXXX: Relay No.

Function

Performs logical OR operation.

Ladder Program Example

<Ladder Diagram>

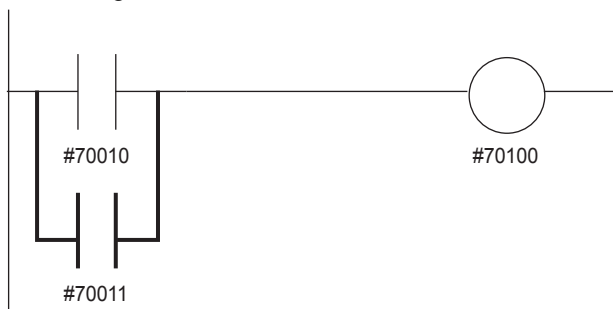

< Program >

```
STR #70010
OR #70011
OUT #70100
```

■ OR-NOT Instruction

Format

OR-NOT #XXXXX
 #XXXXX: Relay No.

Function

Performs logical OR negation operation.

Ladder Program Example

<Ladder Diagram>

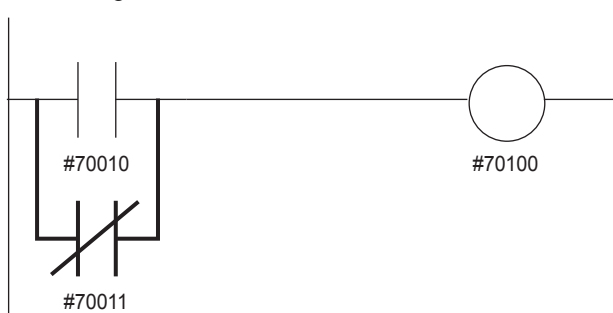

< Program >

```
STR #70010
OR-NOT #70011
OUT #70100
```

■ AND-STR Instruction

Format

AND-STR

Function

Performs logical AND operation with the preliminary results.

Ladder Program Example

<Ladder Diagram>

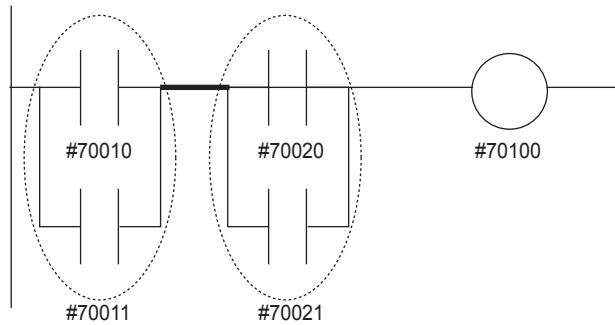

< Program >

```
STR    #70010
OR     #70011
STR    #70020
OR     #70021
AND-STR
OUT    #70100
```

■ OR-STR Instruction

Format

OR-STR

Function

Performs logical OR operation with the preliminary results.

Ladder Program Example

<Ladder Diagram>

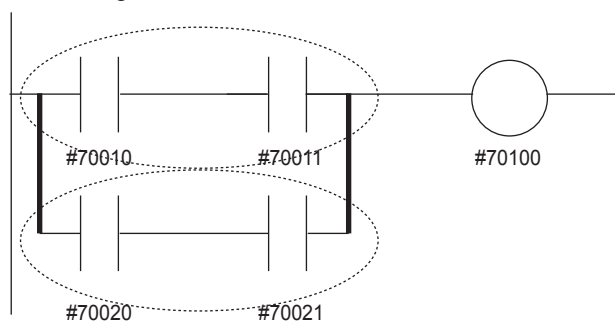

< Program >

```
STR    #70010
AND    #70011
STR    #70020
AND    #70021
OR-STR
OUT    #70100
```

12 Standard Ladder Program

12.2 Instruction Description

■ OUT Instruction

Format

OUT #XXXXX
 #XXXXX: Relay No.

Function

Outputs to the internal or the external.

Ladder Program Example



Two or more times output to the same relay cannot be used.

<Ladder Diagram>

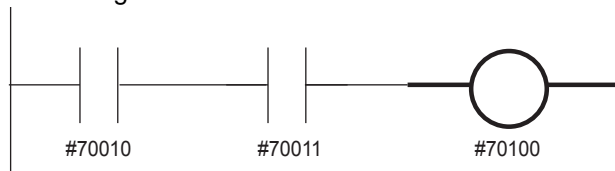

< Program >

```
STR    #70010
AND    #70011
OUT    #70100
```

■ PART Instruction

Format

PART N
 N: Ladder Identification Number (1: System Ladder, 2: User Ladder)

Function

Identifies the system ladder from the user ladder.

Ladder Program Example



This instruction is not displayed in the programming pendant screen.

<Ladder Diagram>

There is no symbol.

System

User

< Program >

```
PART  1
STR   #70010
OUT   #70100
:
PART  2
:
END
```

■ END Instruction

Format

END

Function

Ends the ladder program.

Ladder Program Example



This instruction is not displayed in the programming pendant screen.

<Ladder Diagram>

There is no symbol.

< Program >

```
STR    #70010
OUT    #70100
END
```

■ TMR Instruction

Format

TMR Curr Value, Set Value

Set Value: Register (M000-M499), Decimal (0-65535)

Curr Value: Register (M000-M259)

Set Value Curr Value	Decimal	Register (M000 - M499)
Mxxx (M000 - M259)	0 - 65535 (0.0 - 6553.5sec)	0 - 65535 (0.0 - 6553.5sec)

Function

This instruction is an On Delay Timer to handle the subtraction formula and counter circuit by binary value. The internal clock is 0.1 second.

While the start input is OFF, counting is not performed and Curr Value = Set value is maintained.

Additionally, the TMR contact is turned off.

Curr Value is decremented by 1 every 0.1 seconds as soon as the start input is turned on. The TMR contact is turned on when the Curr Value equals to 0. This state is maintained while the start input is at ON state.

Start Input	Curr Value	TMR Contact
OFF	Set Value	OFF
ON (Curr Value > 0)	Decrement by 1 every 0.1 seconds	OFF
ON (Curr Value = 0)	0	ON
ON→OFF (Curr Value > 0)	Return to Set Value	OFF
ON→OFF (Curr Value = 0)	Return to Set Value	ON→OFF

12 Standard Ladder Program

12.2 Instruction Description

Ladder Program Example

The timer is reset when the NX100 power is turned on. Therefore, Curr Value becomes Set Value by the reset function even if the NX100 power is turned on in the ON state of the timer start input.



Two or more times output to the same relay cannot be used.
It is unable to use the multiple times outputs of the register used as a current value of the TMR instruction and the CNT instruction.

<Ladder Diagram>

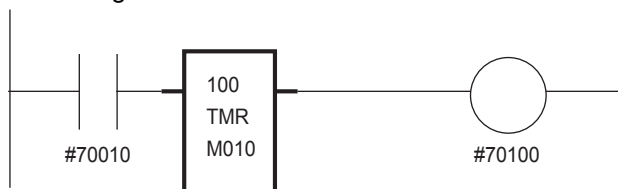

< Program >

```
STR    #70010
TMR    M010,100
OUT    #70100
```

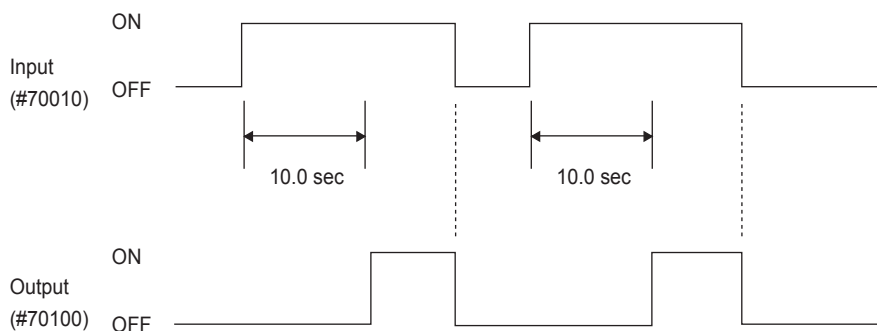

■ CNT Instruction

Format

CNT Curr Value, Set Value

Set Value: Register (M000-M499), Decimal (0-65535)

Curr Value: Register (M000-M259)

Set Value	Decimal	Register (M000 - M499)
Curr Value		
Mxxx (M000 - M259)	0 - 65535	0 - 65535

Function

Even if the counter input is turned to ON from OFF, counting is not performed and Curr Value = Set Value is maintained while the reset input is ON. Additionally, the CNT contact is turned OFF. The Curr Value is decremented by 1 each time the counter input is turned to ON from OFF in OFF state of the reset input. The TMR contact is turned on when the Curr Value becomes 0. This state is maintained in OFF state of the reset signals. Powering on the NX100 resets the counter. Consequently, the Curr Value remains as the Set Value by

the reset function even if the counter input is in the ON state when the NX100 power is on.

Reset Input	Curr Value	CNT Contact
ON	Set Value	OFF
OFF (Curr Value > 0)	Decrement by 1 each time the counter input turns from OFF→ON	OFF
OFF (Curr Value = 0)	0	ON
OFF→ON (Curr Value > 0)	Return to Set Value	OFF
OFF→ON (Curr Value = 0)	Return to Set Value	ON→OFF

Ladder Program Example

The counter input is ignored once the counter is counted up. Start counting after turning the counter input to OFF from ON. The reset input is given priority when the counter input and reset input are turned on at the same time.



Two or more times output to the same relay cannot be used. It is unable to use the multiple times outputs of the register used as a current value of the TMR instruction and the CNT instruction.

<Ladder Diagram>

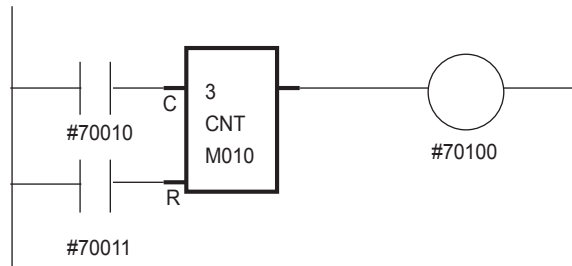

< Program >

```
STR #70010 Counter Input
STR #7011 Reset Input
CNT M010, 3 CNT instruction
OUT #70100 Output
```

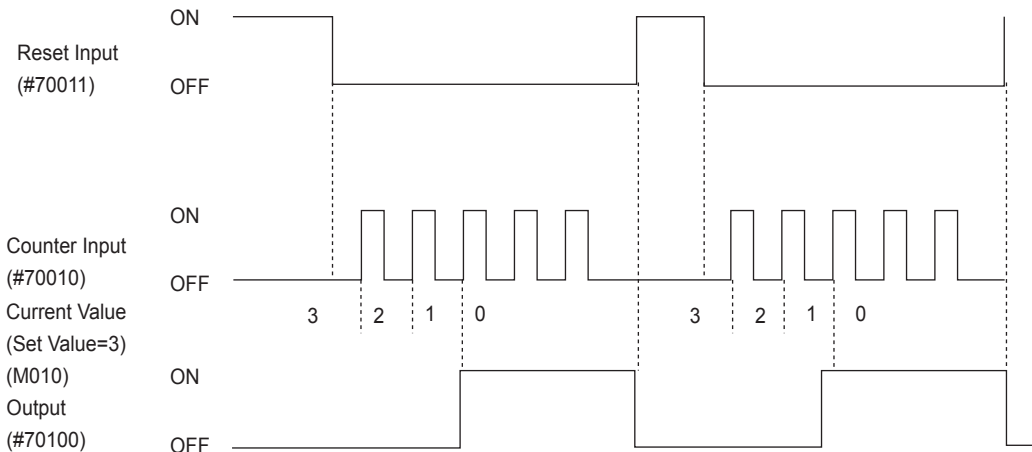

12 Standard Ladder Program

12.2 Instruction Description

■ GSTR Instruction / GOUT Instruction

Format

GSTR #XXXX0
 GOUT #XXXX0
 #XXXX0: Relay No. (byte)

Function

The GSTR instruction stores the relay number (8 bits).
 The GOUT instruction outputs 8 bits data stored by the GSTR instruction to the relay number (8 bits).

Ladder Program Example

NOTE The GSTR instruction and the GOUT instruction should be pairs.
 The output cannot be done to the same relay two or more times.

<Ladder Diagram>

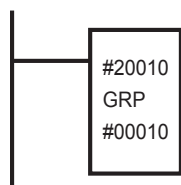

< Program >

```
GSTR #20010
GOUT #00010
```

■ PLS Instruction

Format

PLS #XXXXXX
 #XXXXXX: Relay No.

Function

The PLS instruction outputs one scanning pulse signal when specified signal is turned to ON from OFF.

Ladder Program Example

NOTE The output cannot be done to the same relay two or more times.

<Ladder Diagram>

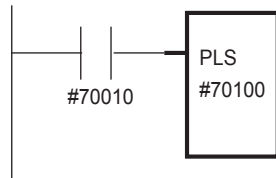

< Program >

```
STR #70010
PLS #70100
```

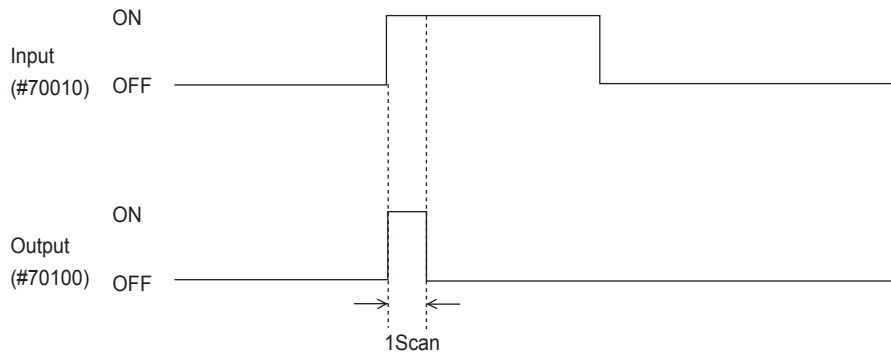
■ PLF Instruction

Format

PLF #XXXXX
#XXXXX: Relay No.

Function

The PLF instruction outputs one scanning pulse signal when specified signal is turned to OFF from ON.

Ladder Program Example

NOTE The output cannot be done to the same relay two or more times.

<Ladder Diagram>

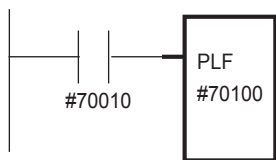

< Program >

```
STR #70010
PLF #70100
```

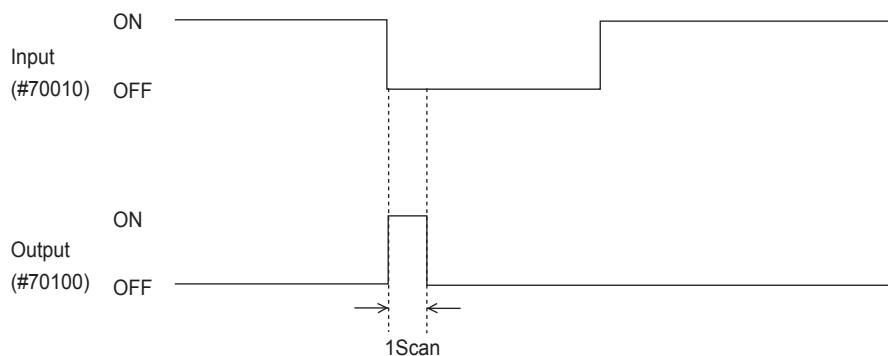

12 Standard Ladder Program

12.2 Instruction Description

■ ADD Instruction

Format

ADD S1, S2, D

S1: Source 1	Register (M000-M499) Decimal (0-65535)
S1: Source 2	Register (M000-M499) Decimal (0-65535)
D: Destination	Register (M000-M299)

Function

S1 and S2 (16 bits unsigned binary data) are added and the addition result is output to D when the input signal is in ON state. As a result of calculation, the carry flag (#50640) and the zero flag (#50641) of a specific output are changed. The error flag (#50642) is not used.

<Arithmetic Flag>

S1+S2	D	Carry Flag	Zero Flag	Error Flag
0	0	0	1	Not Used(0)
1-65535	1-65535	0	0	Not Used(0)
65536	0(S1+S2-65536)	1	1	Not Used(0)
65536 or more	S1+S2-65536	1	0	Not Used(0)

Unused flag is cleared.

Ladder Program Example



It is unable to use the multiple times outputs of register used as a current value of the TMR instruction and the CNT instruction.

<Ladder Diagram>

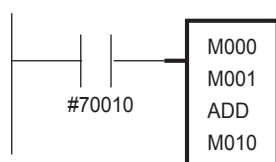

< Program>

```
STR #70010
ADD M000, M001, M010
```

■ SUB Instruction

Format

SUB S1, S2, D

S1: Source 1	Register (M000-M499) Decimal (0-65535)
S1: Source 2	Register (M000-M499) Decimal (0-65535)
D: Destination	Register (M000-M299)

Function

S1 and S2 (16 bits unsigned binary data) are subtracted and the subtraction result is output to D when input signal is in ON state. As a result of calculation, the carry flag (#50640) and the zero flag (#50641) of a specific output are changed. The error flag (#50642) is not used.

<Arithmetic Flag>

S1-S2	D	Carry Flag	Zero Flag	Error Flag
0	0	0	1	Not Used(0)
1-65535	1-65535	0	0	Not Used(0)
Negative Number	S1-S2+65536	1	0	Not Used(0)

Unused flag is cleared.

Ladder Program Example



It is unable to use the multiple times outputs of register used as a current value of the TMR instruction and the CNT instruction.

<Ladder Diagram>

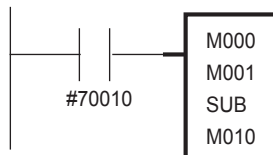

< Program>

```

STR #70010
SUB M000, M001, M010
  
```

12 Standard Ladder Program

12.2 Instruction Description

■ MUL Instruction

Format

MUL S1, S2, Dn

S1: Source 1	Register (M000-M499) Decimal (0-65535)
S1: Source 2	Register (M000-M499) Decimal (0-65535)
Dn+1(High), Dn(Low): Destination	Register (M000-M299)

Function

S1 and S2 (16 bits unsigned binary data) are multiplied and the multiplication result is output to D when the input signal is in ON state. The carry flag (#50640), the zero flag (#50641), and the error flag (#50642) are not used.

<Arithmetic Flag>

S1 x S2	Dn+1	Dn	Carry Flag	Zero Flag	Error Flag
0	0	0	Not Used(0)	Not Used(0)	Not Used(0)
1-65535	0	1-65535	Not Used(0)	Not Used(0)	Not Used(0)
65536 or more	High Word	Low Word	Not Used(0)	Not Used(0)	Not Used(0)

Unused flag is cleared.

Ladder Program Example



It is unable to use the multiple times outputs of the register used as a current value of the TMR instruction and the CNT instruction.

<Ladder Diagram>

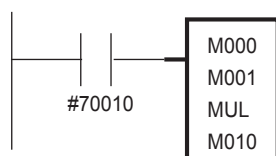

< Program>

```
STR #70010
MUL M000,M001,M010
When results=65536:
M011=1(0000000000000001 Binary Data)
M010=0(0000000000000000 Binary Data)
```

■ DIV Instruction

Format

DIV S1, S2, D

S1: Source 1	Register (M000-M499) Decimal (0-65535)
S1: Source 2	Register (M000-M499) Decimal (0-65535)
D: Destination (Quotient)	Register (M000-M299)

Function

S1 and S2 (16 bits unsigned binary data) are divided and the division result (Quotient) is output to D when the input signal is in ON state. As a result of calculation, the error flag (#50642) of a specific output is changed. The carry flag (#50640) and the zero flag (#50641) are not used.

<Arithmetic Flag>

S1	S2	D	Carry Flag	Zero Flag	Error Flag
0-65535	Excepted for 0	Quotient	Not Used(0)	Not Used(0)	0
0-65535	0	No changes	Not Used(0)	Not Used(0)	1

Unused flag is cleared.

Ladder Program Example



It is unable to use the multiple times outputs of the register used as a current value of the TMR instruction and the CNT instruction.

<Ladder Diagram>

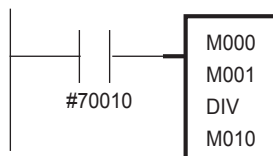

< Program >

```

STR #70010
DIV M000, M001, M010

```

12 Standard Ladder Program

12.2 Instruction Description

■ MOD Instruction

Format

MOD S1, S2, D

S1: Source 1	Register (M000-M499) Decimal (0-65535)
S1: Source 2	Register (M000-M499) Decimal (0-65535)
D: Destination (Residuum)	Register (M000-M299)

Function

S1 and S2 (16 bits unsigned binary data) are divided and the division result (Residuum) is output to D when the input signal is in ON state. As a result of calculation, the error flag (#50642) of a specific output is changed. The carry flag (#50640) and the zero flag (#50641) are not used.

<Arithmetic Flag>

S1	S2	D	Carry Flag	Zero Flag	Error Flag
0-65535	Excepted for 0	Surplus	Not Used(0)	Not Used(0)	0
0-65535	0	No changes	Not Used(0)	Not Used(0)	1

Unused flag is cleared.

Ladder Program Example



It is unable to use the multiple times outputs of the register used as a current value of the TMR instruction and the CNT instruction.

<Ladder Diagram>

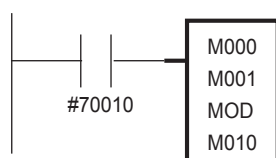

< Program >

```
STR #70010
MOD M000,M001,M010
```

■ BIN Instruction

Format

BIN S, D

S: Source	Register (M000-M499) Relay (byte) #XXXX0 Relay (word) W#XXXX0
D: Destination	Register (M000-M299) Relay (byte) #XXXX0 Relay (word) W#XXXX0

Function

S (BCD data) is converted to binary data and is output to D when the input signal is in ON state. As a result of calculation, the carry flag (#50640) and the error flag (#50642) of a specific output are changed. The zero flag (#50641) is not used.

<Arithmetic Flag>

S	D	Carry Flag	Zero Flag	Error Flag
BCD	BIN	0/1	Not Used(0)	0
Excepted for BCD	No Changes	0	Not Used(0)	1

The carry flag is set when the conversion result is the relay (byte) and the conversion data is more than 256 (BCD). Unused flag is cleared.

Ladder Program Example



The output cannot be done to the same relay two or more times. It is unable to use the multiple times outputs of the register used as a current value of the TMR instruction and the CNT instruction.

<Ladder Diagram>

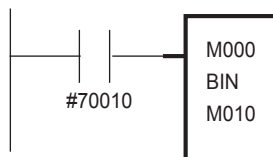

< Program >

```

STR #70010
BIN M000,M010

```

12 Standard Ladder Program

12.2 Instruction Description

■ BCD Instruction

Format

BCD S, D

S: Source	Register (M000-M499) Relay (byte) #XXXX0 Relay (word) W#XXXX0
D: Destination	Register (M000-M299) Relay (byte) #XXXX0 Relay (word) W#XXXX0

Function

S (binary data) is converted to BCD data and is output to D when the input signal is in ON state. As a result of calculation, the carry flag (#50640) and the error flag (#50642) of a specific output are changed. The zero flag (#50641) is not used.

<Arithmetic Flag>

S	D	Carry Flag	Zero Flag	Error Flag
9999 or less (binary data)	BCD	0/1	Not Used(0)	0
10000 or more (binary data)	No Changes	0	Not Used(0)	1

The carry flag is set when the conversion result is the relay (byte) and the conversion data is more than 256 (BCD). Unused flag is cleared.

Ladder Program Example



The output cannot be done to the same relay two or more times. It is unable to use the multiple times outputs of the register used as a current value of the TMR instruction and the CNT instruction.

<Ladder Diagram>

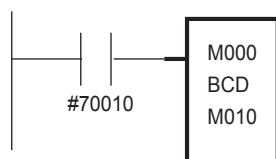

< Program >

```
STR #70010
BCD M000,M010
```

■ MOV Instruction

Format

MOV S, D

S: Source	Register (M000-M499) Decimal (0-65535) Relay (byte) #XXXX0 Relay (word) W#XXXX0
D: Destination	Register (M000-M299) Relay (byte) #XXXX0 Relay (word) W#XXXX0

Function

S is output to D in ON state of the input signal. As a result of calculation, the carry flag (#50640) of a specific output is changed. The zero flag (#50641) and the error flag (#50642) are not used. The carry flag is set when the transmission result is the relay (byte) and the transmission data is more than 256 (BCD).

Ladder Program Example



The output cannot be done to the same relay two or more times. It is unable to use the multiple outputs of the register used as a current position of the TMR instruction and the CNT instruction.

<Ladder Diagram>

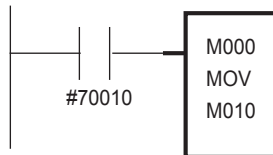

< Program >

```

STR #70010
MOV M000, M010

```

12 Standard Ladder Program

12.2 Instruction Description

■ WAND Instruction

Format

WAND S1, S2, D

S1: Source	Register (M000-M499)
S2: Source	Decimal (0-65535)
	Relay (byte) #XXXX0
	Relay (word) W#XXXX0
D: Destination	Register (M000-M299)
	Relay (byte) #XXXX0
	Relay (word) W#XXXX0

Function

Logical AND operation between S1 and S2 is performed and the result is output to D when the input signal is in ON state. The logic operation is performed in each correspondence bit of S1 and S2.

$D \leftarrow S1 \cap S2$		
S1	1100110011001100	Binary Data
S2	1010101010101010	Binary Data
	↓	
D	1000100010001000	Binary Data

Ladder Program Example



The output cannot be done to the same relay two or more times.
It is unable to use the multiple outputs of the register used as a current position of the TMR instruction and the CNT instruction.

<Ladder Diagram>

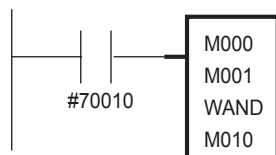

< Program >

```
STR #70010
WAND M000, M001, M010
```

■ WOR Instruction

Format

WOR S1, S2, D

S1: Source	Register (M000-M499)
S2: Source	Decimal (0-65535) Relay (byte) #XXXX0 Relay (word) W#XXXX0
D: Destination	Register (M000-M299) Relay (byte) #XXXX0 Relay (word) W#XXXX0

Function

Logical OR operation between S1 and S2 is performed and the result is output to D when the input signal is in ON state. The logic operation is performed in each correspondence bit of S1 and S2.

$D \leftarrow S1 \cup S2$		
S1	1100110011001100	Binary Data
S2	1010101010101010	Binary Data
	↓	
D	1110111011101110	Binary Data

Ladder Program Example



The output cannot be done to the same relay two or more times. It is unable to use the multiple outputs of the register used as a current position of the TMR instruction and the CNT instruction.

<Ladder Diagram>

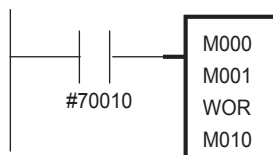

< Program >

```
STR #70010
WOR M000, M001, M010
```

12 Standard Ladder Program

12.2 Instruction Description

■ WXOR Instruction

Format

WXOR S1, S2, D

S1: Source	Register (M000-M499)
S2: Source	Decimal (0-65535)
	Relay (byte) #XXXX0
	Relay (word) W#XXXX0
D: Destination	Register (M000-M299)
	Relay (byte) #XXXX0
	Relay (word) W#XXXX0

Function

Exclusive OR operation between S1 and S2 is performed and the result is output to D when the input signal is in ON state. The logic operation is performed in each correspondence bit of S1 and S2.

$D \leftarrow (S1 \cup S2) \cap (\overline{S1} \cap \overline{S2})$		
S1	1100110011001100	Binary Data
S2	1010101010101010	Binary Data
	↓	
D	0110011001100110	Binary Data

Ladder Program Example



The output cannot be done to the same relay two or more times.
It is unable to use the multiple times outputs of the register used as a current position of the TMR instruction and the CNT instruction.

<Ladder Diagram>

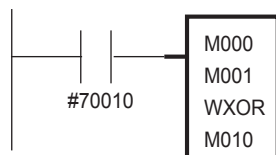

< Program >

```
STR #70010
WXOR M000, M001, M010
```

■ WNOT Instruction

Format

WNOT S, D

S: Source	Register (M000-M499) Decimal (0-65535) Relay (byte) #XXXX0 Relay (word) W#XXXX0
D: Destination	Register (M000-M299) Relay (byte) #XXXX0 Relay (word) W#XXXX0

Function

Logical negation operation of S is performed and the result is output to D when the input signal is in ON state. The logic operation is performed in each correspondence bit of S1 and S2.

$D \leftarrow \overline{S}$		
S1	1100110011001100	Binary Data
	↓	
D	0011001100110011	Binary Data

Ladder Program Example



The output cannot be done to the same relay two or more times.
It is unable to use the multiple times outputs of the register used as a current position of the TMR instruction and the CNT instruction.

<Ladder Diagram>

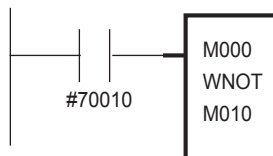

< Program >

```

STR #70010
WNOT M000, M010

```

12 Standard Ladder Program

12.2 Instruction Description

■ SHL Instruction

Format

SHL S, n, D

S: Source	Register (M000-M499) Decimal (0-65535) Relay (byte) #XXXX0 Relay (word) W#XXXX0
n: Shift count	Decimal (0-16)
D: Destination	Register (M000-M299) Relay (byte) #XXXX0 Relay (word) W#XXXX0

Function

16 bits data contents of S is shifted to the high bit direction (left) n times and the result is output to D when the input signal is in ON state. 0 is shifted to the lowest bit (LSB) and the highest bit (MSB) is shifted to the carry flag.

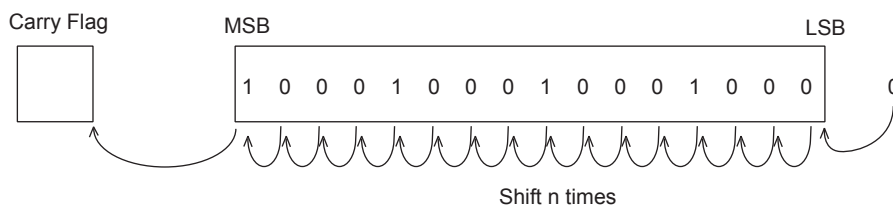

Ladder Program Example

NOTE

The output cannot be done to the same relay two or more times. It is unable to use the multiple times outputs of the register used as a current position of the TMR instruction and the CNT instruction. The operation is performed each scanning when the input signal is in ON state. For one time operation, use the pulse output instruction (PLS, PLF) in the input circuit.

<Ladder Diagram>

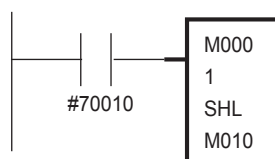

< Program>

```
STR #70010
SHL M000,1,M010
```

When M000 = 1000100010001000
(binary data), the result is as follows.
M010: 0001000100010000
Carry flag: 1

■ SHR Instruction

Format

SHR S, n, D

S: Source	Register (M000-M499) Decimal (0-65535) Relay (byte) #XXXX0 Relay (word) W#XXXX0
n: Shift count	Decimal (0-16)
D: Destination	Register (M000-M299) Relay (byte) #XXXX0 Relay (word) W#XXXX0

Function

16 bits data contents of S is shifted to the low bit direction (right) n times and the result is output to D when the input signal is in ON state. 0 is shifted to the highest bit (MSB) and the lowest bit (LSB) is shifted to the carry flag.

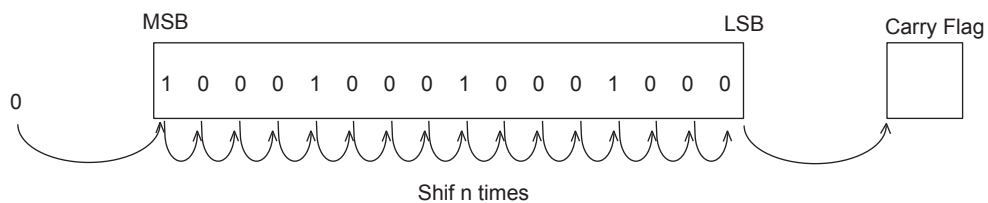

Ladder Program Example



The output cannot be done to the same relay two or more times. It is unable to use the multiple times outputs of the register used as a current position of the TMR instruction and the CNT instruction. The operation is performed each scanning when the input signal is in ON state. For one time operation, use the pulse output instruction (PLS, PLF) in the input circuit.

<Ladder Diagram>

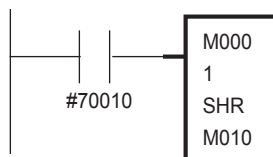

< Program >

```
STR #70010
SHR M000, 1, M010
```

When M000 = 1000100010001000
(binary data), the result is as follows.
M010: 0100010001000100
Carry flag: 0

12 Standard Ladder Program

12.2 Instruction Description

■ ROL Instruction

Format

ROL S, n, D

S: Source	Register (M000-M499) Decimal (0-65535) Relay (byte) #XXXX0 Relay (word) W#XXXX0
n: Shift count	Decimal (0-16)
D: Destination	Register (M000-M299) Relay (byte) #XXXX0 Relay (word) W#XXXX0

Function

16 bits data contents of S is shifted to the high bit direction (left) n times and the result is output to D when the input signal is in ON state. The highest bit (MSB) is shifted to the carry flag and the lowest bit (LSB).

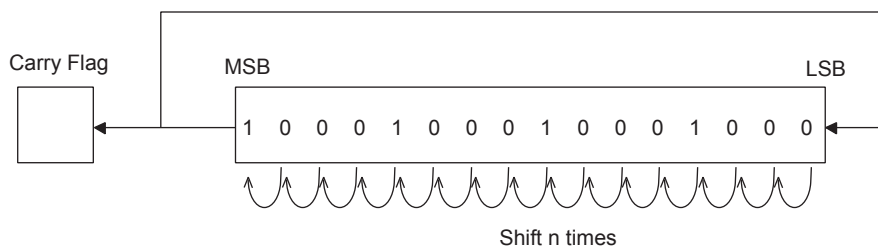

Ladder Program Example



The output cannot be done to the same relay two or more times. It is unable to use the multiple times outputs of the register used as a current position of the TMR instruction and the CNT instruction. The operation is performed each scanning when the input signal is in ON state. For one time operation, use the pulse output instruction (PLS, PLF) in the input circuit.

<Ladder Diagram>

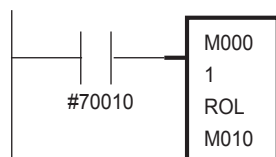

< Program >

```
STR #70010
ROL M000, 1, M010
```

When M000 = 1000100010001000
(binary data), the result is as follows.
M010: 0001000100010001
Carry flag: 1

■ ROR Instruction

Format

ROR S, n, D

S: Source	Register (M000-M499) Decimal (0-65535) Relay (byte) #XXXX0 Relay (word) W#XXXX0
n: Shift count	Decimal (0-16)
D: Destination	Register (M000-M299) Relay (byte) #XXXX0 Relay (word) W#XXXX0

Function

16 bits data contents of S is shifted to the low bit direction (right) n times and the result is output to D when the input signal is in ON state. The lowest bit (LSB) is shifted to the carry flag and the highest bit (MSB).

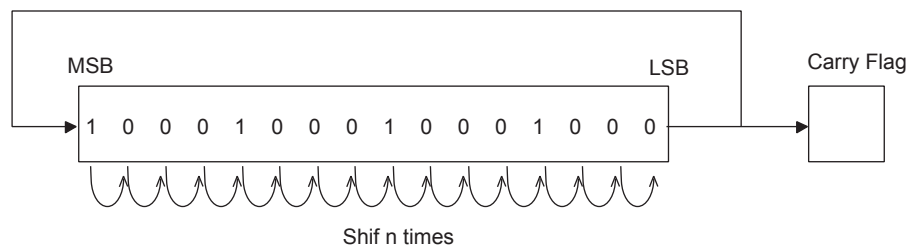

Ladder Program Example



The output cannot be done to the same relay two or more times. It is unable to use the multiple times outputs of the register used as a current position of the TMR instruction and the CNT instruction. The operation is performed each scanning when the input signal is in ON state. For one time operation, use the pulse output instruction (PLS, PLF) in the input circuit.

<Ladder Diagram>

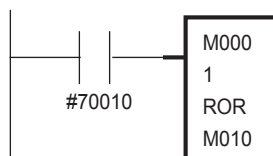

< Program >

```
STR #70010
ROL M000, 1, M010
```

When M000 = 1000100010001000
(binary data), the result is as follows.
M010: 0100010001000100
Carry flag: 0

12.3 Arithmetic Flag

■ Flag Type

The arithmetic flag is a signal to reflect calculation result in the operation of the following steps. There are three types of flags. These flags are allocated to the following specific outputs.

- #50640: Carry Flag
- #50641: Zero Flag
- #50642: Error Flag



Refer to "11.1 List of Usable Instructions" for the instructions which influence the flag.

Carry Flag

- Case of ADD Instruction:
This flag is set when the place of digit is moved to the left as a result of the operation.
- Case of SUB Instruction:
This flag is set when the result is negative.

Zero Flag

- Case of ADD or SUB Instruction:
This flag is set when the result is 0.

Error Flag

- This flag is set when the error occurs. The instruction is not executed.

■ Flag Transition under Scanning

- The flag is cleared before ladder program processing of every scanning.
- When the processing of the instruction which influences the flag starts, the flag is set by the operation result when the execution condition of the instruction consists. The flag is cleared when the execution condition of the instruction is a failure.
- The state of the flag does not change regardless of execution or non-execution in the processing of the instruction which does not influence the flag.

12.4 Arc Welding

■ Ladder Program List



System ladder section differs according to the version. Check the version of the software used for the NX100.

System Ladder Section



These system ladders are for the software versions before NS3.97.00A (□) -00. See page 12-40 for the system ladders if the software version is NS3.97.00A (□) -00 or later.

Standard ladders are prepared for each application prior to shipment. Ladder programs cannot be edited.

12 Standard Ladder Program

12.4 Arc Welding

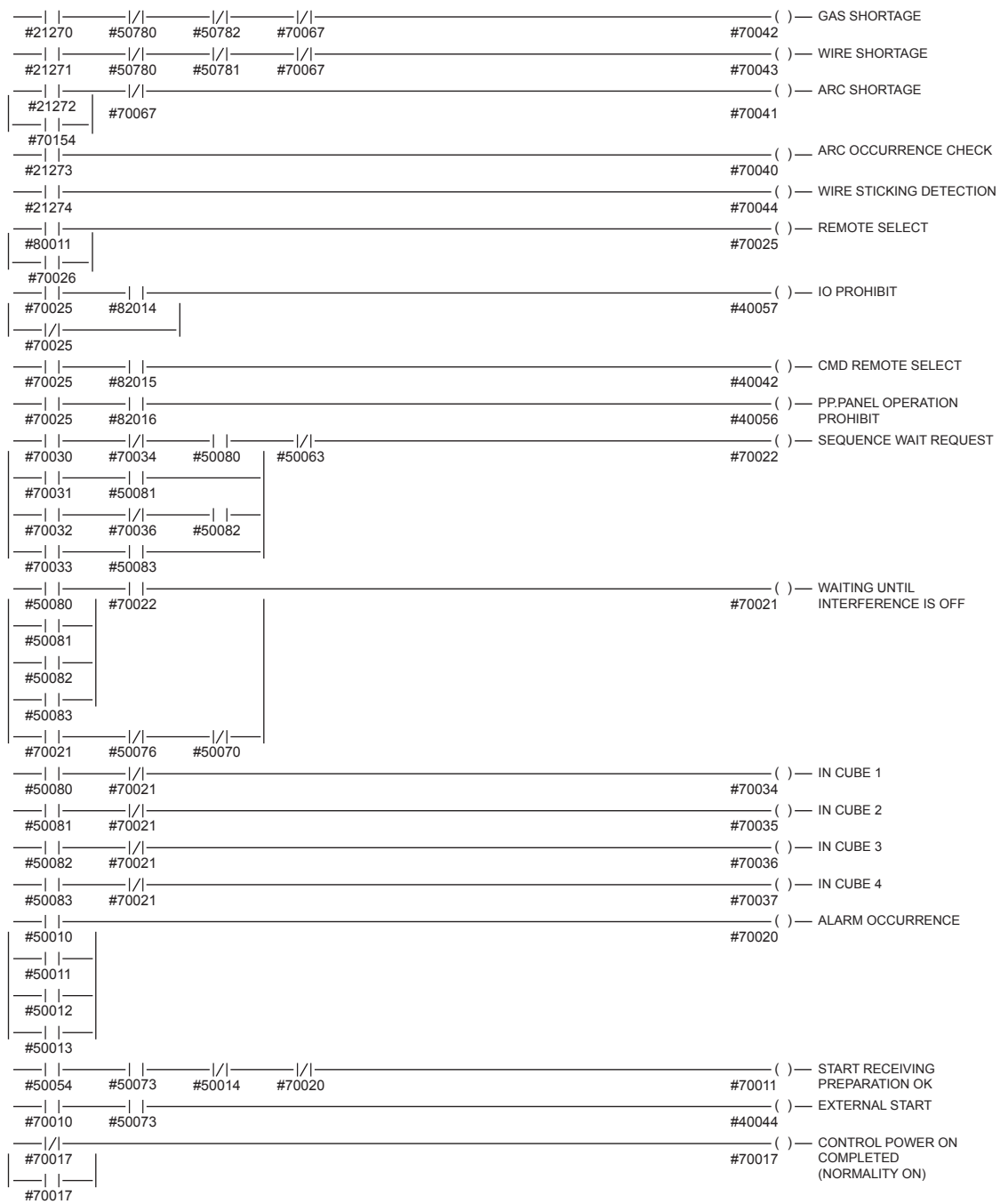

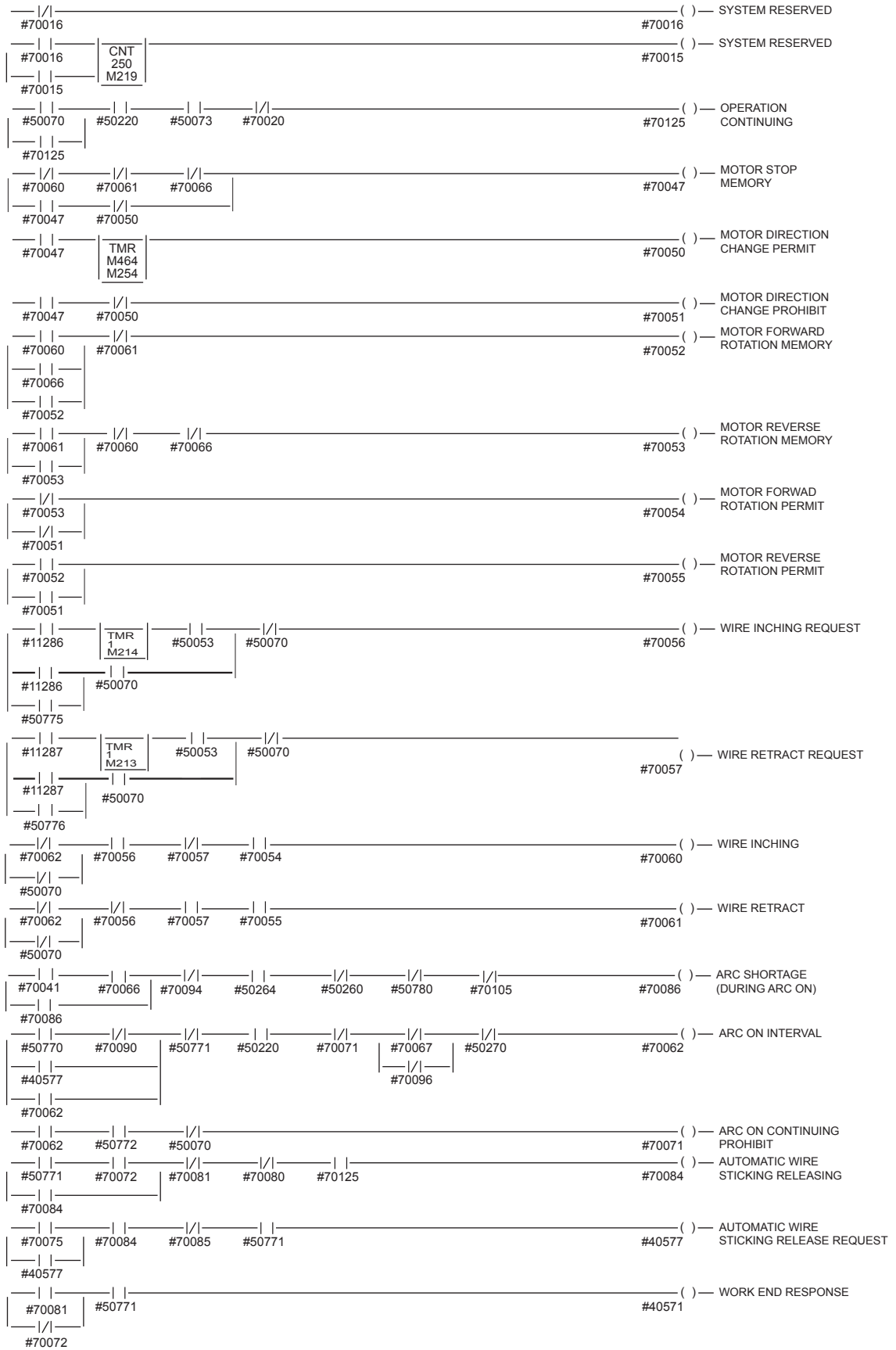

12 Standard Ladder Program
 12.4 Arc Welding

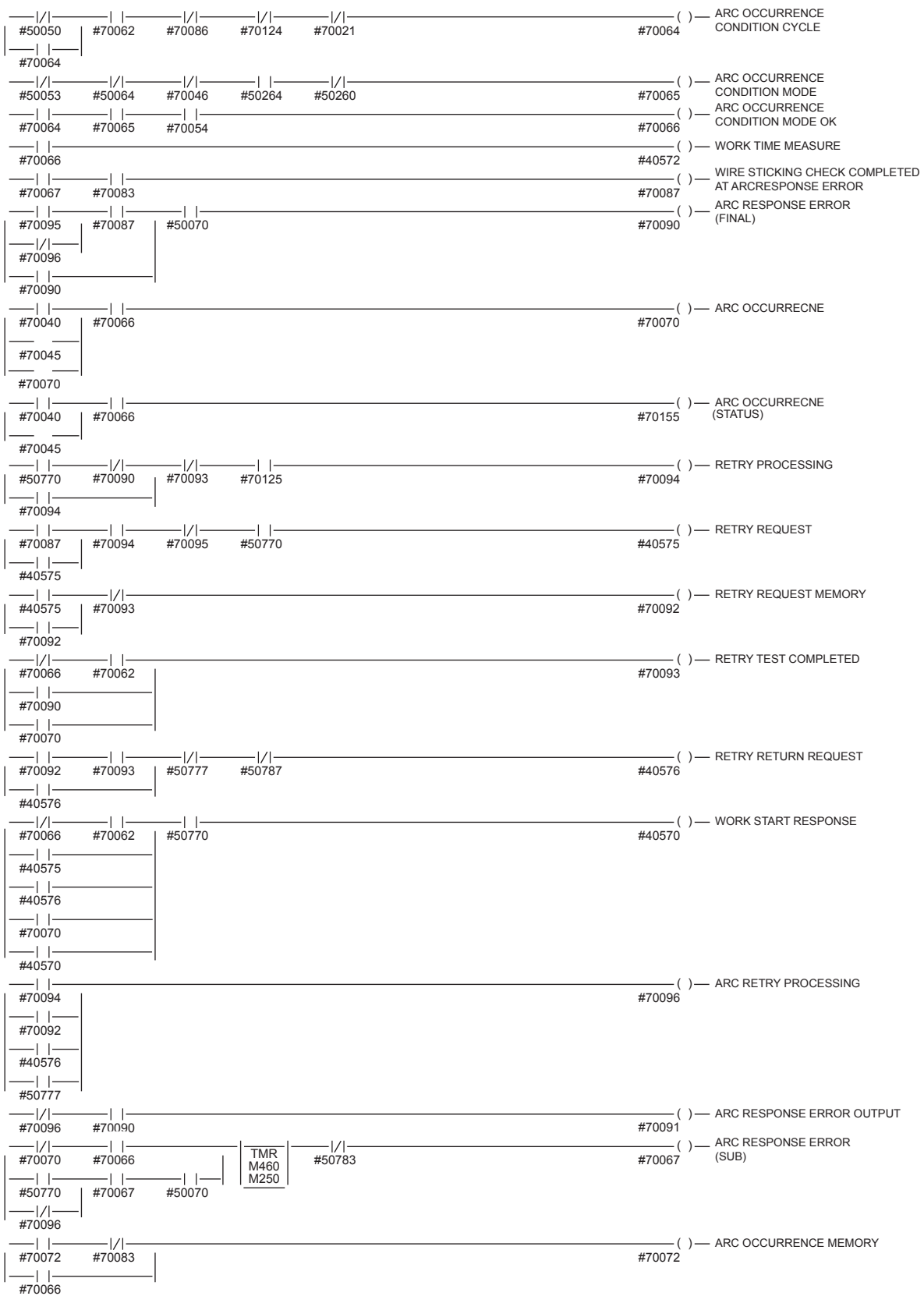

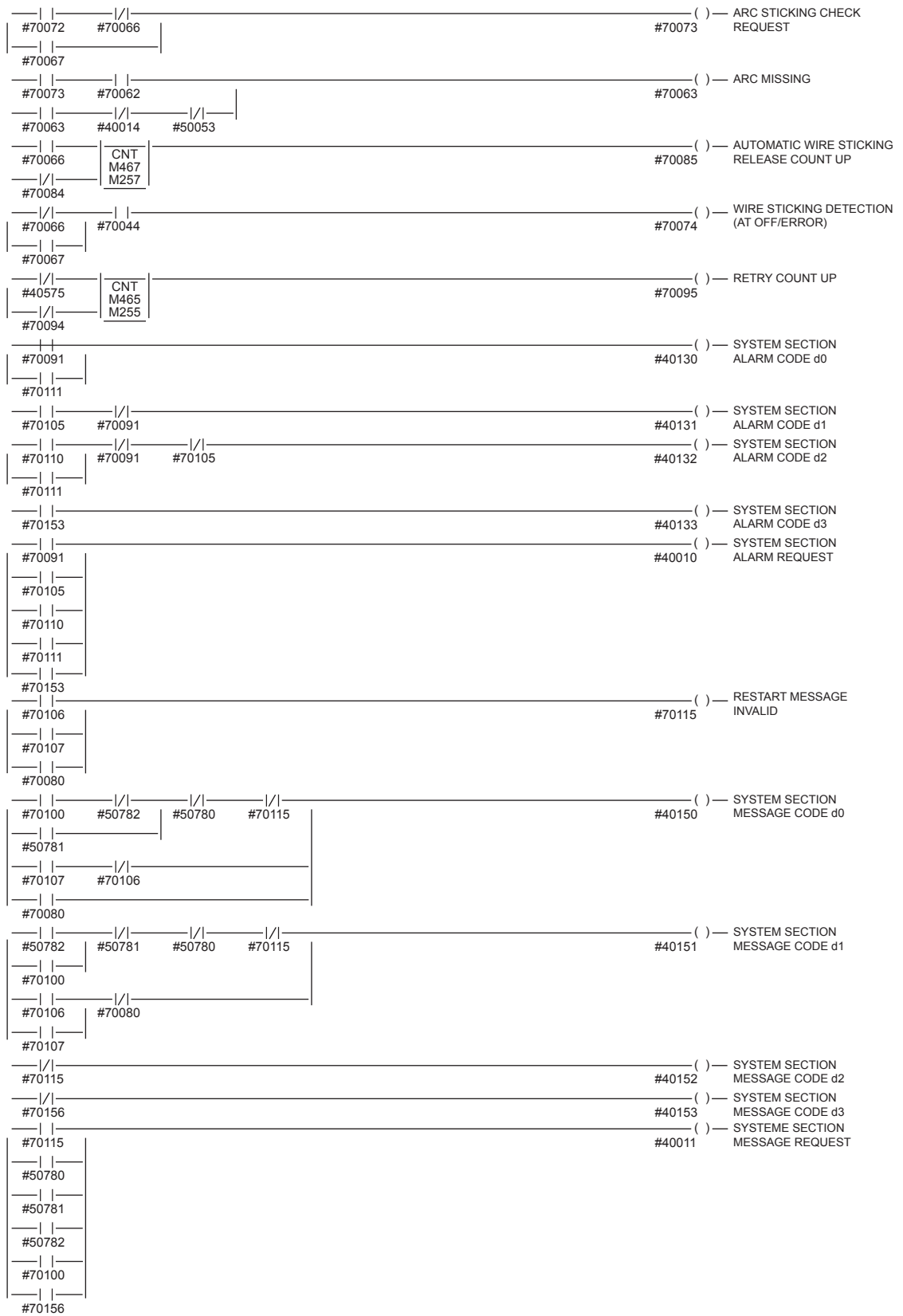

12 Standard Ladder Program
 12.4 Arc Welding

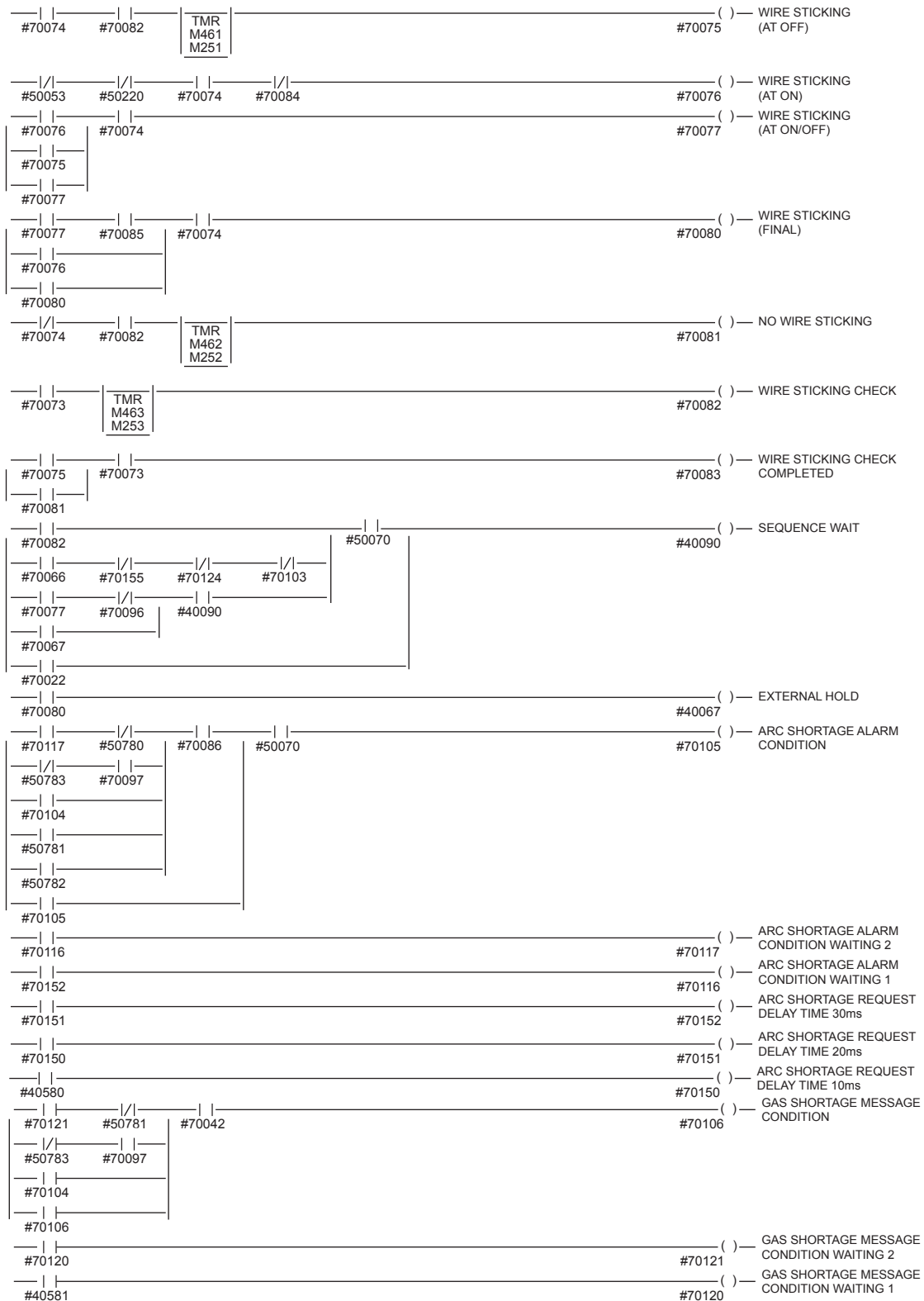

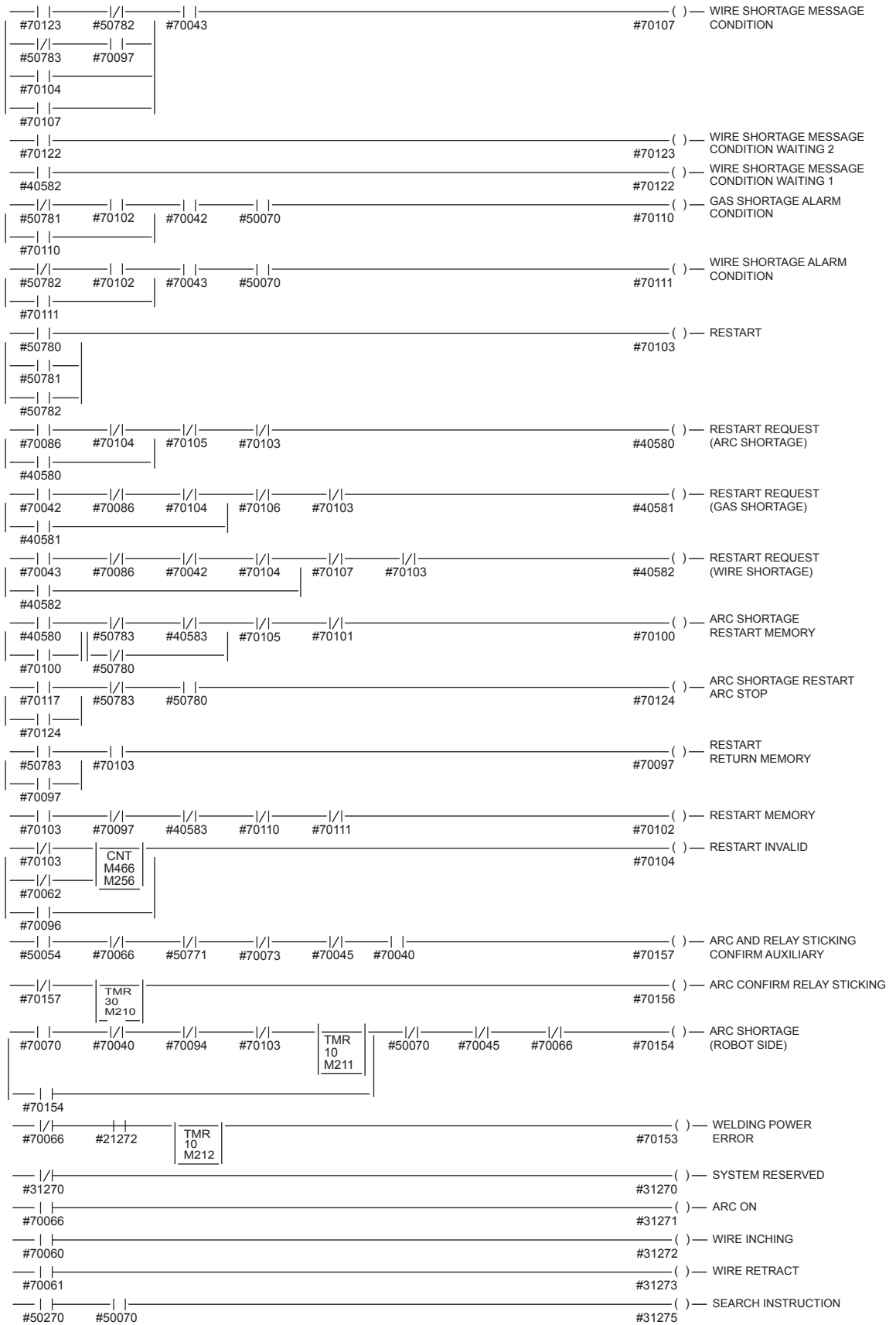

12 Standard Ladder Program
 12.4 Arc Welding

System Ladder Section (Software version: NS3.97.00A (□) -00 or later)

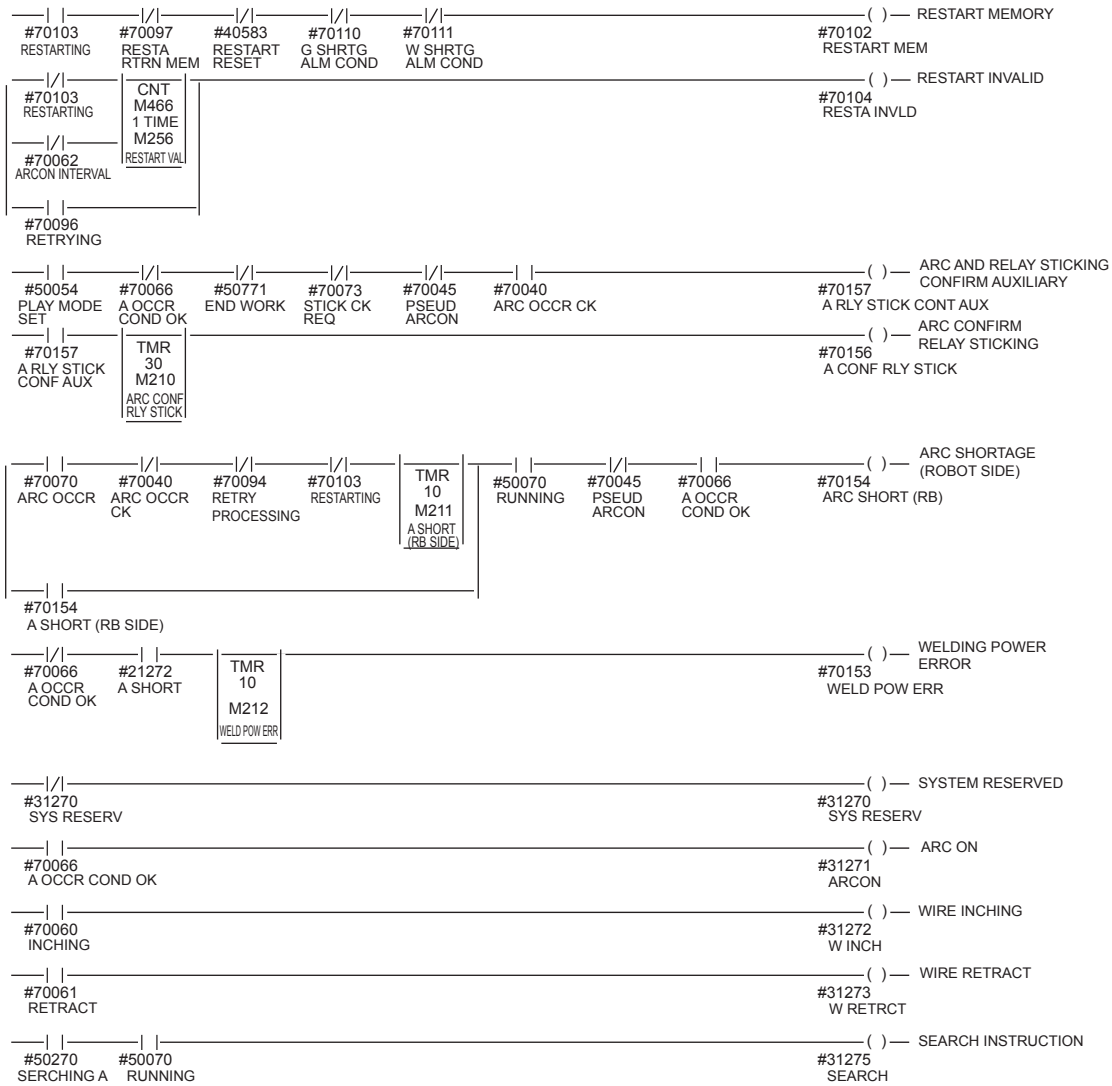

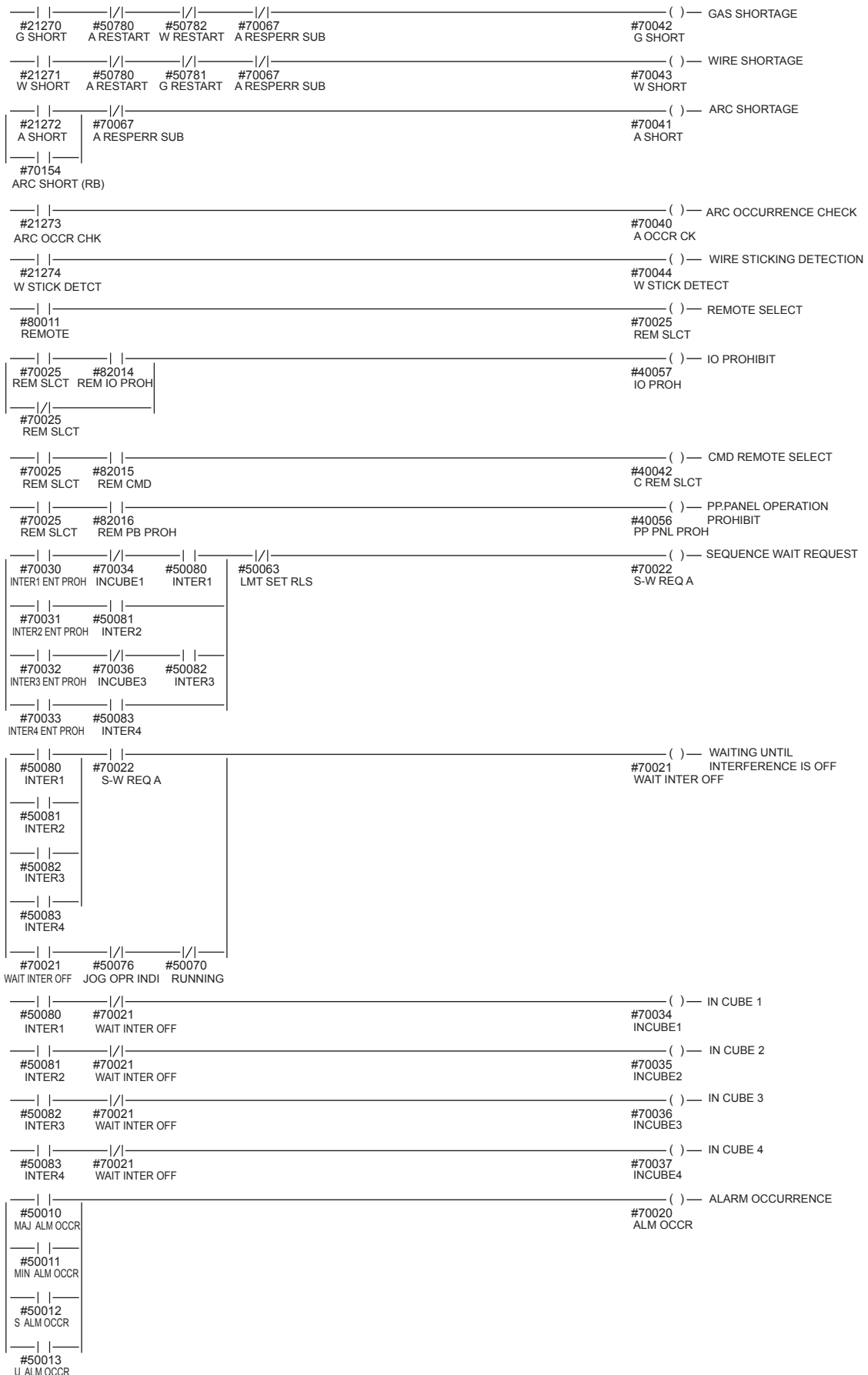

12 Standard Ladder Program
 12.4 Arc Welding

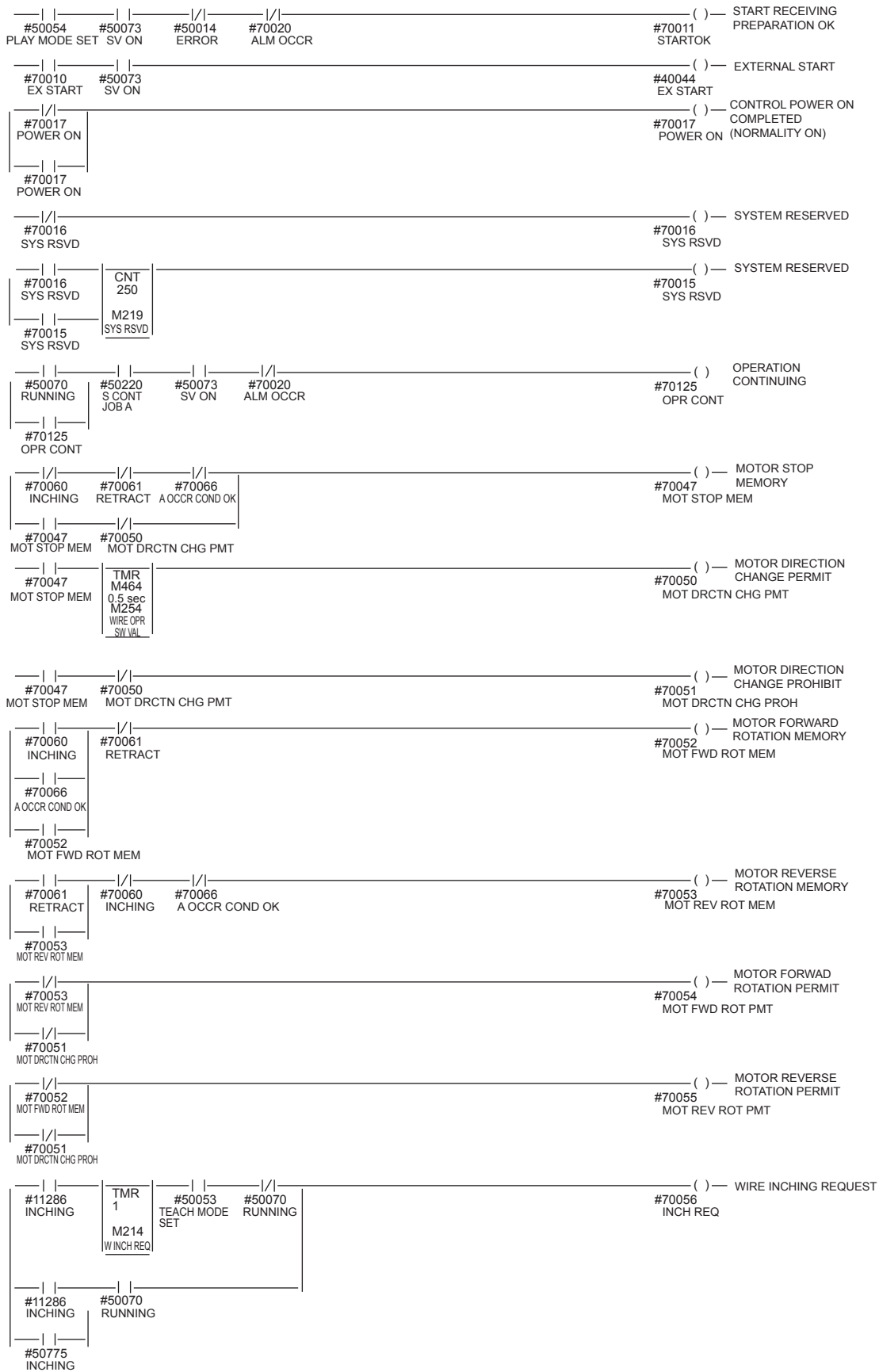

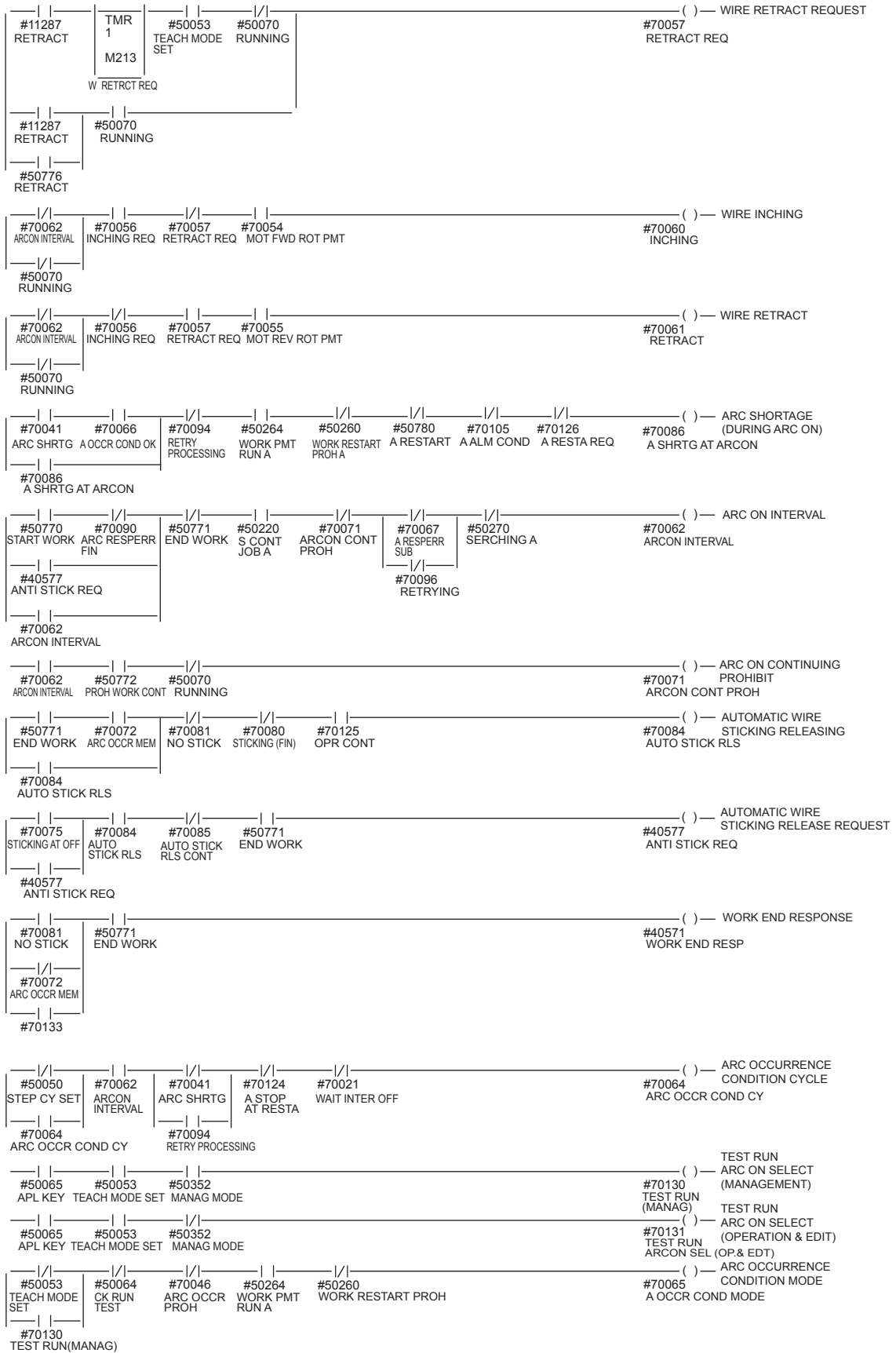

12 Standard Ladder Program

12.4 Arc Welding

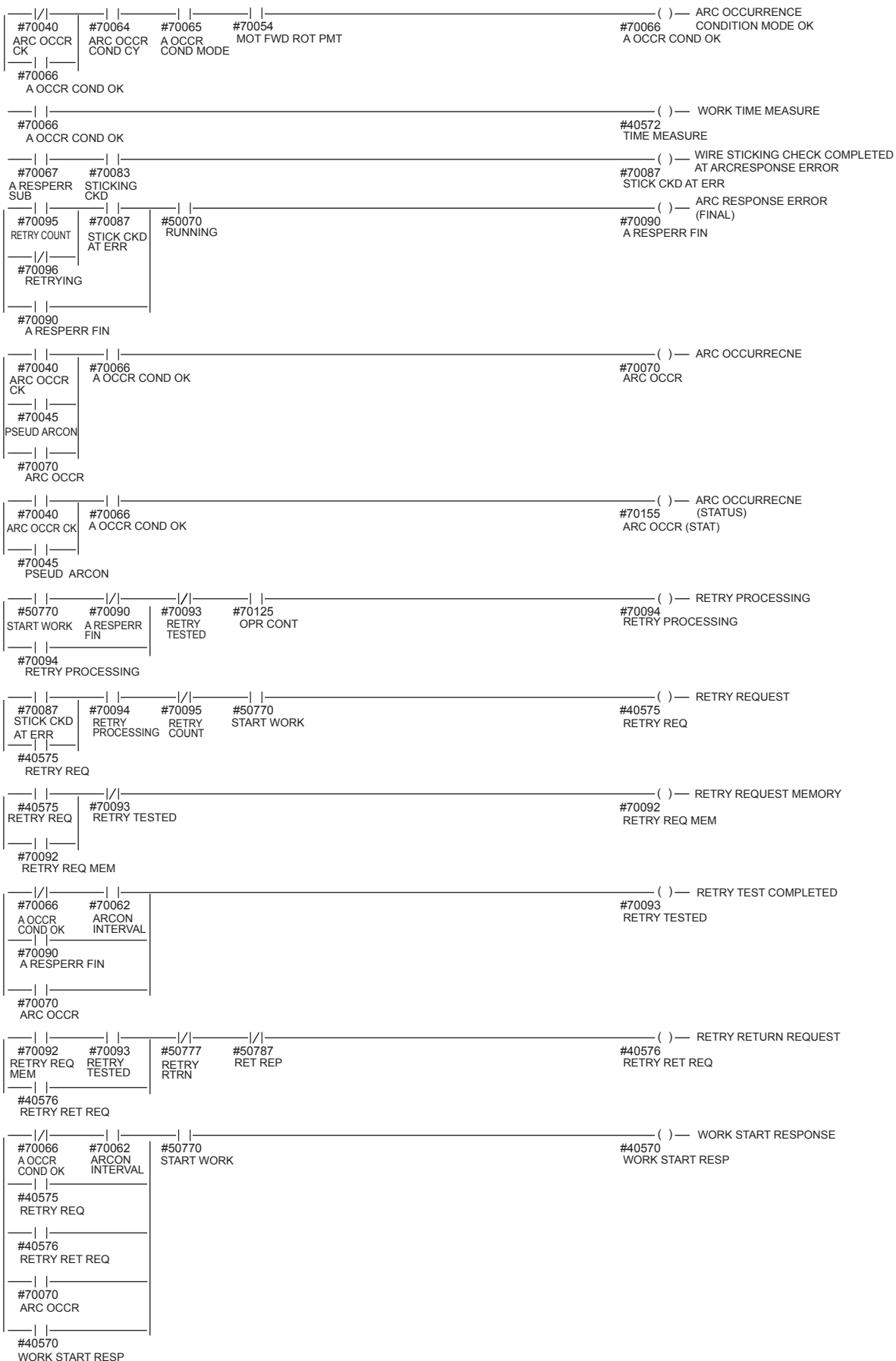

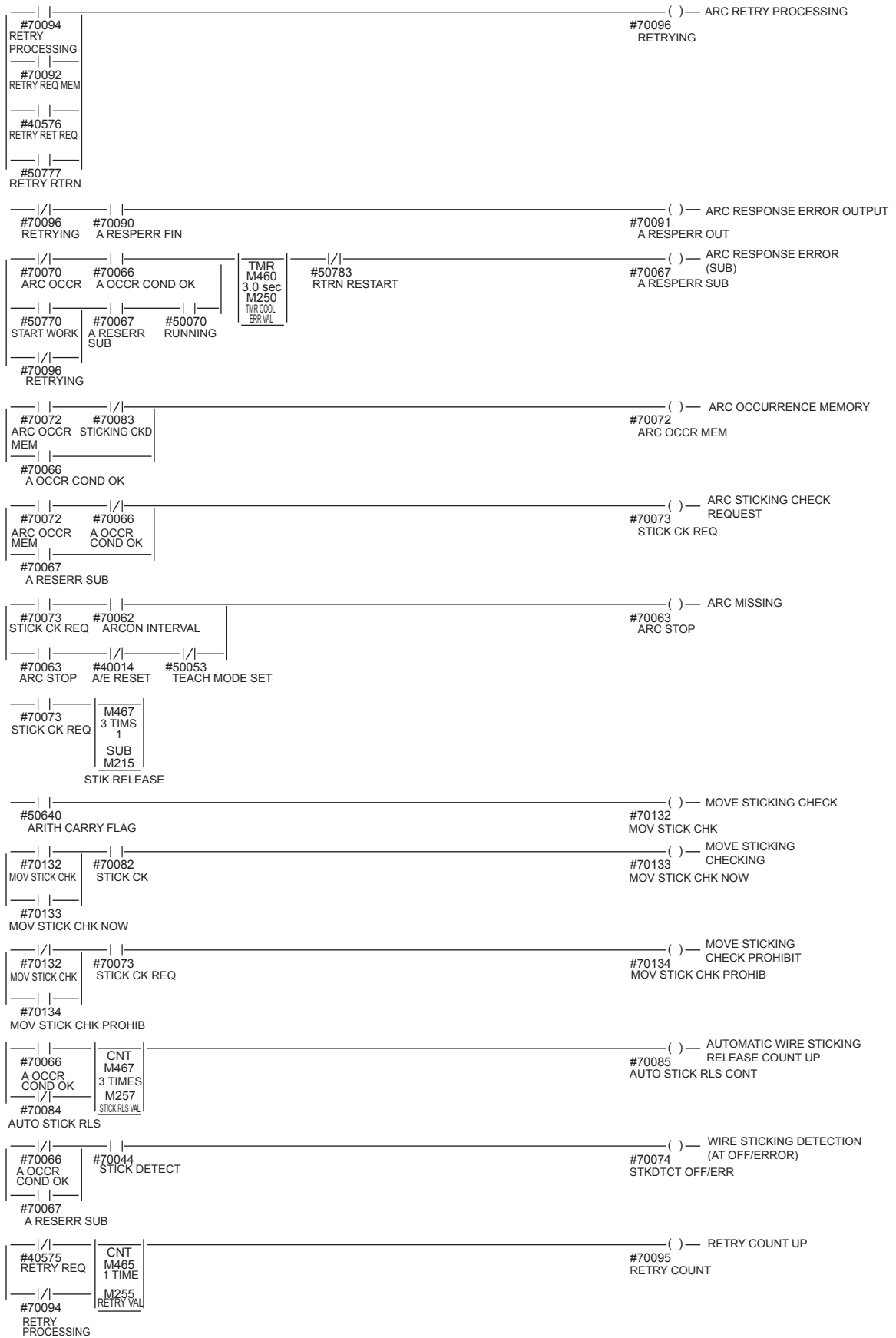

12 Standard Ladder Program
 12.4 Arc Welding

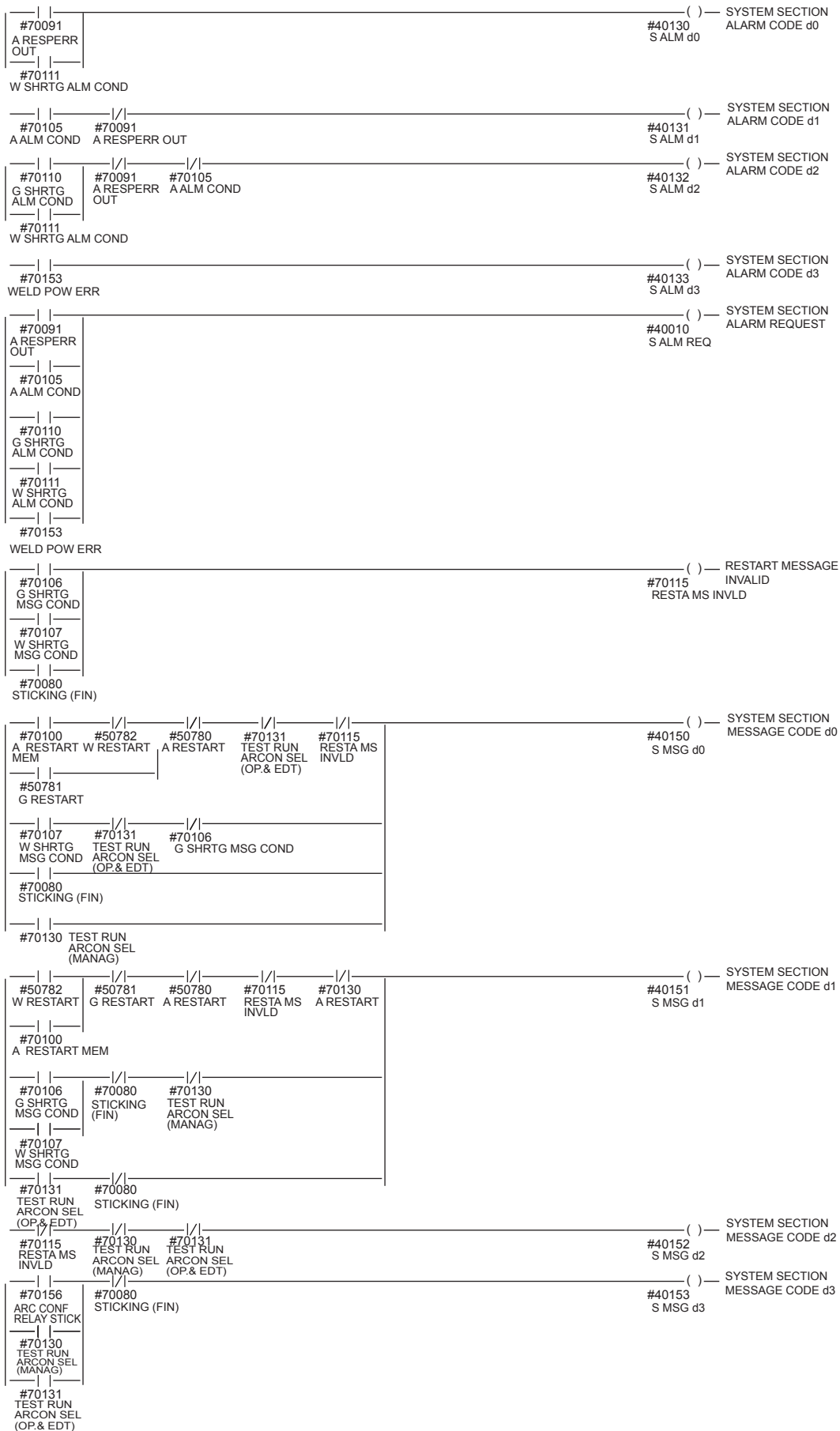

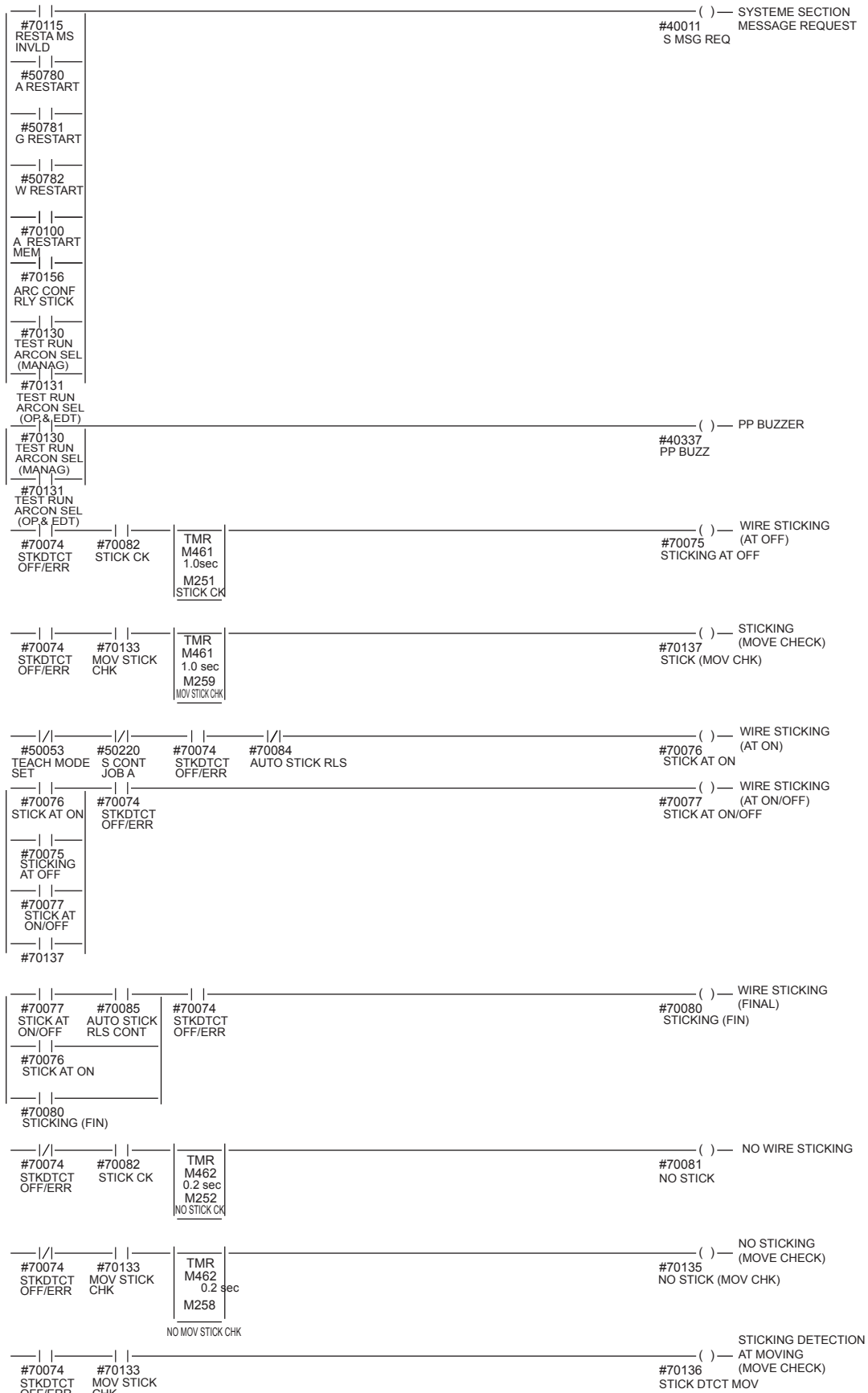

12 Standard Ladder Program
 12.4 Arc Welding

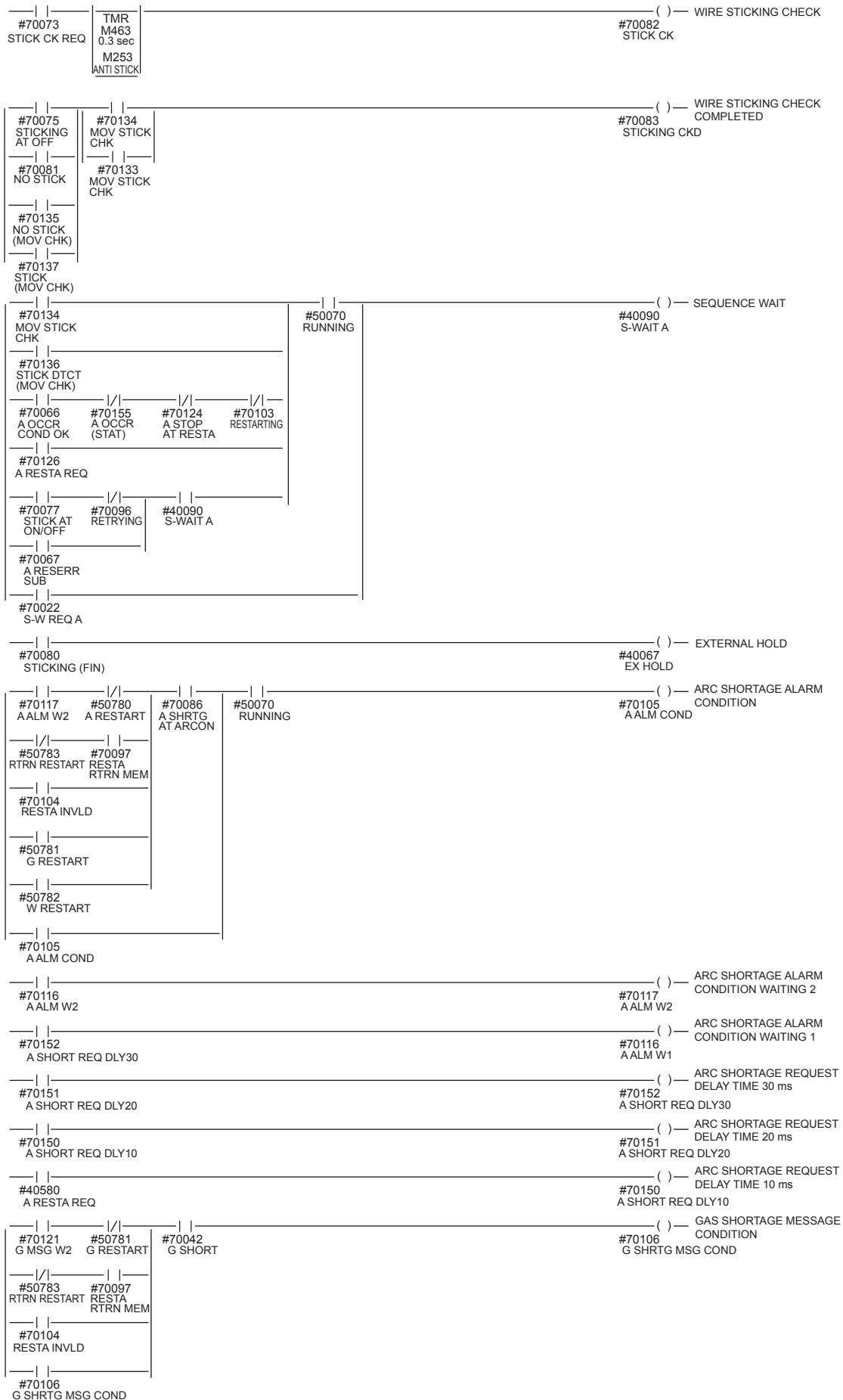

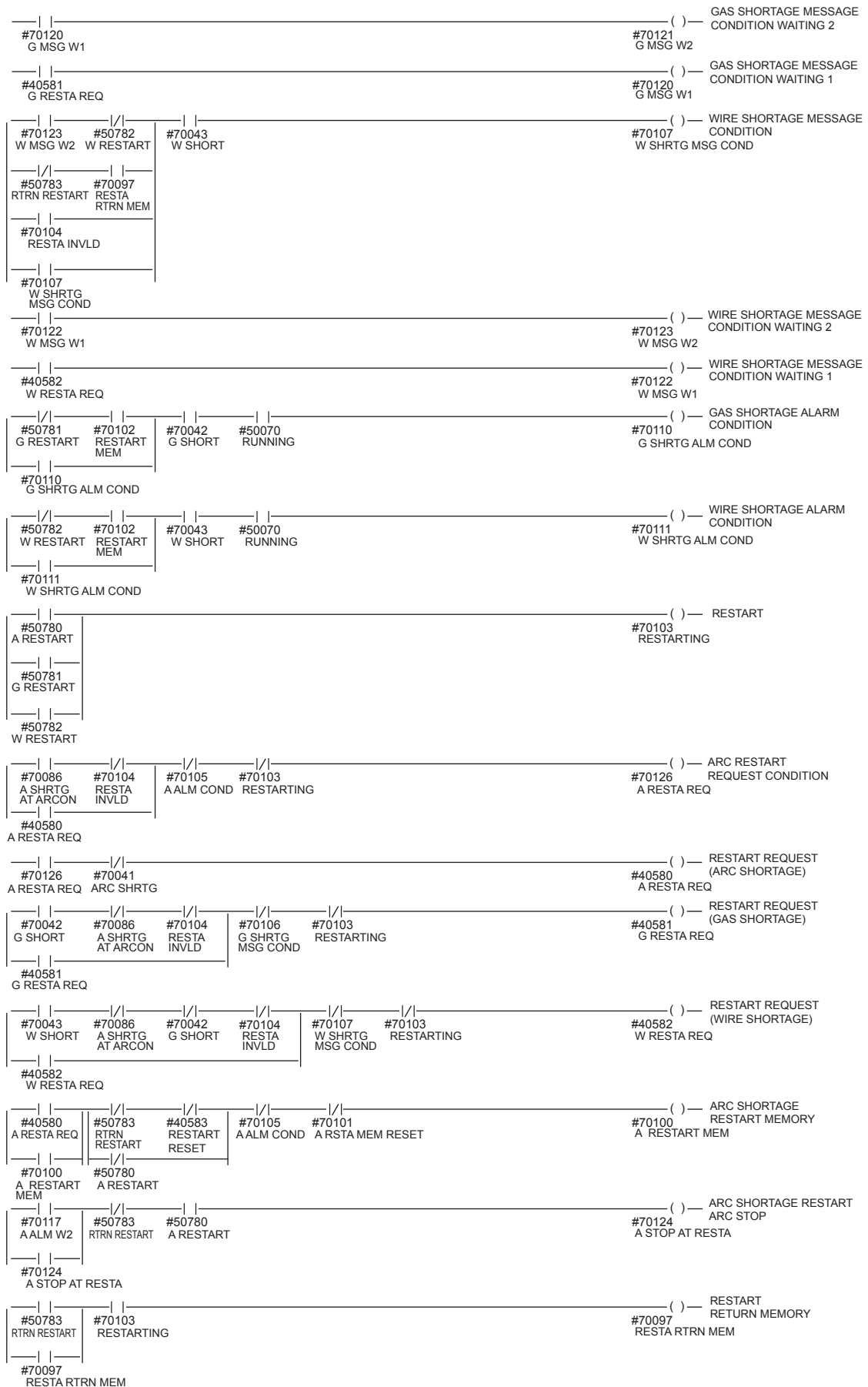

12 Standard Ladder Program

12.4 Arc Welding

User Ladder Section

Signal connection specification and interface signals with system ladder are prepared prior to shipment. Including, these signals, ladder programs can be edited.

#20010 EX START	()	EXTERNAL START	#70010 EX START
#20012 MST JOB CAL	()	MASTER JOB CALL	#40030 MST JOB CAL
#20013 A/E RST	()	ALARM/ERROR RESET	#40014 A/E RESET
#20015 PLY MOD SLCT	()	PLAY MODE SELECT	#40041 PLY MODE SLCT
#20016 TEACH SLCT	()	TEACH MODE SELECT	#40040 TEACH SLCT
#20020 INTER1 ENT PROH	()	INTERFERENCE 1 ENTRANCE PROHIBIT	#70030 INTER1 ENT PROH
#20021 INTER2 ENT PROH	()	INTERFERENCE 2 ENTRANCE PRHIBIT	#70031 INTER2 ENT PROH
#20022 ARC OCCR PROH	()	WORK PROHIBIT (ARC OCCURENCE PROHIBIT)	#70046 ARC OCCR PROH
#20023 PSEUD ARCON	()	WORK RESPONSE (PSEUDO ARC ON RESPONSE)	#70045 PSEUD ARCON
#20026 WEAV PROH	()	WEAVING PROHIBIT	#40047 WEAVE PROH
#20027 SENS PROH	()	SENSING PROHIBIT	#40600 SENSE PROH
#11284 ARSTA MEM RESET	()	ARC SHORTAGE RESTART MEMORY RESET	#70101 ARSTA MEM RESET
#11285 RESTART RESET	()	RESTART RESET REQUEST	#40583 RESTART RESET
#50070 RUNNING	()	OPERATING	#30010 OPERAT
#50073 SV ON	()	SERVO ON	#30011 SV ON
#50020 TOP MASTER	()	TOP MASTER JOB	#30012 TOP MAST JOB
#70020 ALM OCCR	()	ALARM/ERROR OCCURENCE	#30013 ALARM/ERR OCCR
#50014 ERROR			
#50015 M BAT WEAK	()	BATTERY ALARM	#30014 BATT ALM
#50016 E BAT WEAK			
#40057 IO PROH	()	REMOTE MODE SELECTING	#30015 REMOTE MOD SLCT
#50056 C REMOTE SET			
#50054 PLAY MODE SET	()	PLAY MODE SELECTING	#30016 PLY MOD SLCT
#50053 TEACH MODE SET	()	TEACH MODE SELECTING	#30017 TEACH MOD SLCT
#70034 INCUBE1	()	IN CUBE 1	#30020 IN CUBE1
#70035 INCUBE2	()	IN CUBE 2	#30021 IN CUBE2

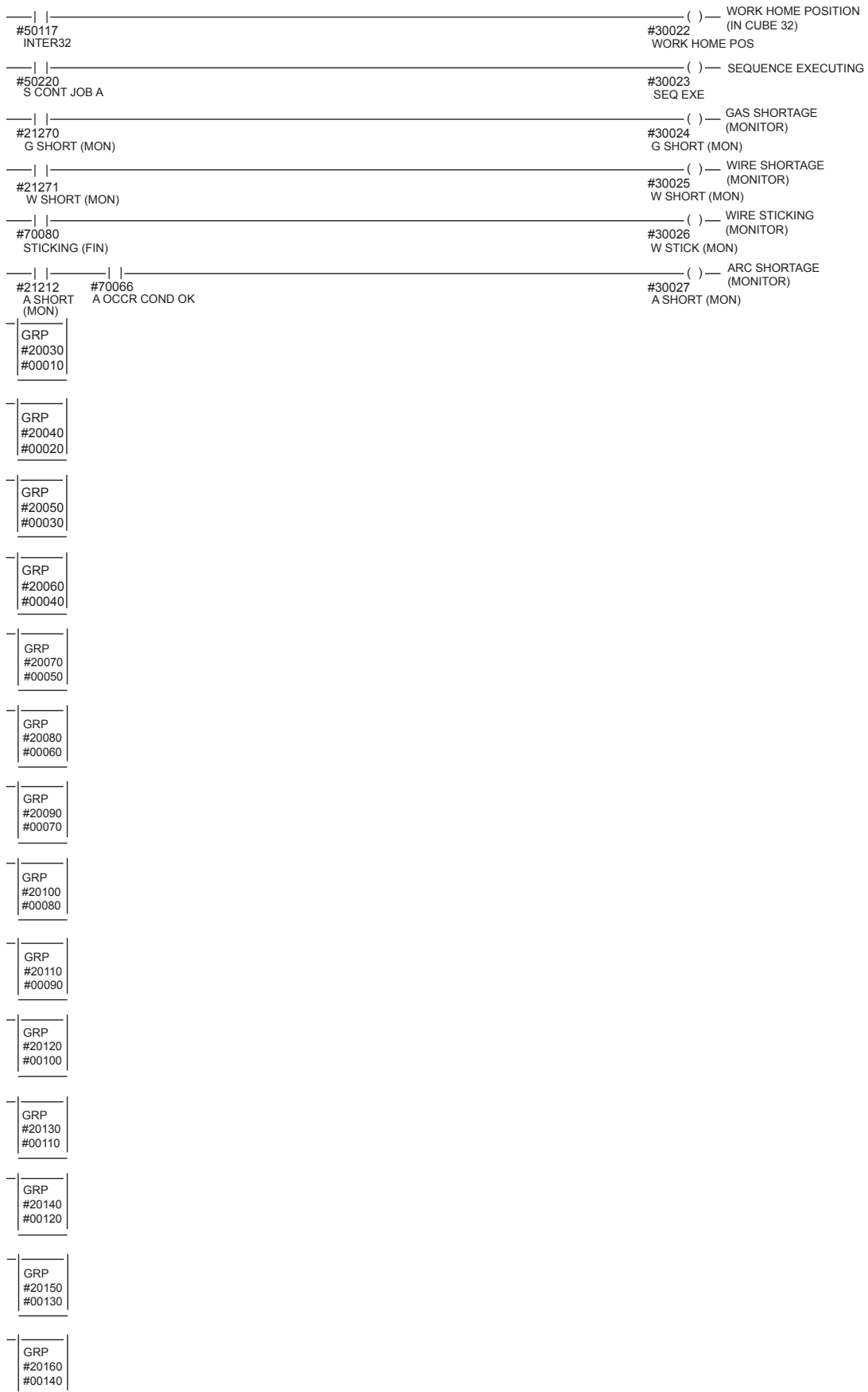

12 Standard Ladder Program

12.4 Arc Welding

GRP
#20170
#00150

GRP
#20180
#00160

GRP
#20190
#00170

GRP
#20200
#00180

GRP
#20210
#00190

GRP
#20220
#00200

GRP
#20230
#00210

GRP
#20240
#00220

GRP
#20250
#00230

GRP
#20260
#00240

GRP
#20270
#00250

GRP
#20280
#00260

GRP
#20290
#00270

GRP
#20300
#00280

GRP
#20310
#00290

GRP
#20320
#00300

GRP
#20330
#00310

GRP
#20340
#00320

GRP
#20350
#00330

GRP
#20360
#00340

GRP
#20370
#00350

GRP
#20380
#00360

GRP
#20390
#00370

GRP
#20400
#00380

GRP
#20410
#00390

GRP
#20420
#00400

GRP
#20430
#00410

GRP
#20440
#00420

GRP
#20450
#00430

GRP
#20460
#00440

GRP
#20470
#00450

GRP
#20480
#00460

GRP
#20490
#00470

GRP
#20500
#00480

GRP
#20510
#00490

GRP
#20520
#00500

12 Standard Ladder Program

12.4 Arc Welding

GRP
#20530
#00510

GRP
#20540
#00520

GRP
#20550
#00530

GRP
#20560
#00540

GRP
#20570
#00550

GRP
#20580
#00560

GRP
#20590
#00570

GRP
#20600
#00580

GRP
#20610
#00590

GRP
#20620
#00600

GRP
#20630
#00610

GRP
#20640
#00620

GRP
#20650
#00630

GRP
#20660
#00640

GRP
#20670
#00650

GRP
#20680
#00660

GRP
#20690
#00670

GRP
#20700
#00680

GRP
#20710
#00690

GRP
#20720
#00700

GRP
#20730
#00710

GRP
#20740
#00720

GRP
#20750
#00730

GRP
#20760
#00740

GRP
#20770
#00750

GRP
#20780
#00760

GRP
#20790
#00770

GRP
#20800
#00780

GRP
#20810
#00790

GRP
#20820
#00800

GRP
#20830
#00810

GRP
#20840
#00820

GRP
#20850
#00830

GRP
#20860
#00840

GRP
#20870
#00850

GRP
#20880
#00860

12 Standard Ladder Program

12.4 Arc Welding

GRP
#20890
#00870

GRP
#20900
#00880

GRP
#20910
#00890

GRP
#20920
#00900

GRP
#20930
#00910

GRP
#20940
#00920

GRP
#20950
#00930

GRP
#20960
#00940

GRP
#20970
#00950

GRP
#20980
#00960

GRP
#20990
#00970

GRP
#21000
#00980

GRP
#21010
#00990

GRP
#21020
#01000

GRP
#21030
#01010

GRP
#21040
#01020

GRP
#21050
#01030

GRP
#21060
#01040

GRP
#21070
#01050

GRP
#21080
#01060

GRP
#21090
#01070

GRP
#21100
#01080

GRP
#21110
#01090

GRP
#21120
#01100

GRP
#21130
#01110

GRP
#21140
#01120

GRP
#21150
#01130

GRP
#21160
#01140

GRP
#21170
#01150

GRP
#21180
#01160

GRP
#21190
#01170

GRP
#21200
#01180

GRP
#10010
#30030

GRP
#10020
#30040

GRP
#10030
#30050

GRP
#10040
#30060

12 Standard Ladder Program

12.4 Arc Welding

GRP
#10050
#30070

GRP
#10060
#30080

GRP
#10070
#30090

GRP
#10080
#30100

GRP
#10090
#30110

GRP
#10100
#30120

GRP
#10110
#30130

GRP
#10120
#30140

GRP
#10130
#30150

GRP
#10140
#30160

GRP
#10150
#30170

GRP
#10160
#30180

GRP
#10170
#30190

GRP
#10180
#30200

GRP
#10190
#30210

GRP
#10200
#30220

GRP
#10210
#30230

GRP
#10220
#30240

GRP
#10230
#30250

GRP
#10240
#30260

GRP
#10250
#30270

GRP
#10260
#30280

GRP
#10270
#30290

GRP
#10280
#30300

GRP
#10290
#30310

GRP
#10300
#30320

GRP
#10310
#30330

GRP
#10320
#30340

GRP
#10330
#30350

GRP
#10340
#30360

GRP
#10350
#30370

GRP
#10360
#30380

GRP
#10370
#30390

GRP
#10380
#30400

GRP
#10390
#30410

GRP
#10400
#30420

12 Standard Ladder Program

12.4 Arc Welding

GRP
#10410
#30430

GRP
#10420
#30440

GRP
#10430
#30450

GRP
#10440
#30460

GRP
#10450
#30470

GRP
#10460
#30480

GRP
#10470
#30490

GRP
#10480
#30500

GRP
#10490
#30510

GRP
#10500
#30520

GRP
#10510
#30530

GRP
#10520
#30540

GRP
#10530
#30550

GRP
#10540
#30560

GRP
#10550
#30570

GRP
#10560
#30580

GRP
#10570
#30590

GRP
#10580
#30600

GRP
#10590
#30610

GRP
#10600
#30620

GRP
#10610
#30630

GRP
#10620
#30640

GRP
#10630
#30650

GRP
#10640
#30660

GRP
#10650
#30670

GRP
#10660
#30680

GRP
#10670
#30690

GRP
#10680
#30700

GRP
#10690
#30710

GRP
#10700
#30720

GRP
#10710
#30730

GRP
#10720
#30740

GRP
#10730
#30750

GRP
#10740
#30760

GRP
#10750
#30770

GRP
#10760
#30780

12 Standard Ladder Program

12.4 Arc Welding

GRP
#10770
#30790

GRP
#10780
#30800

GRP
#10790
#30810

GRP
#10800
#30820

GRP
#10810
#30830

GRP
#10820
#30840

GRP
#10830
#30850

GRP
#10840
#30860

GRP
#10850
#30870

GRP
#10860
#30880

GRP
#10870
#30890

GRP
#10880
#30900

GRP
#10890
#30910

GRP
#10900
#30920

GRP
#10910
#30930

GRP
#10920
#30940

GRP
#10930
#30950

GRP
#10940
#30960

GRP
#10950
#30970

GRP
#10960
#30980

GRP
#10970
#30990

GRP
#10980
#31000

GRP
#10990
#31010

GRP
#11000
#31020

GRP
#11010
#31030

GRP
#11020
#31040

GRP
#11030
#31050

GRP
#11040
#31060

GRP
#11050
#31070

GRP
#11060
#31080

GRP
#11070
#31090

GRP
#11080
#31100

GRP
#11090
#31110

GRP
#11100
#31120

GRP
#11110
#31130

GRP
#11120
#31140

12 Standard Ladder Program
12.4 Arc Welding

GRP
#11130
#31150

GRP
#11140
#31160

GRP
#11150
#31170

GRP
#11160
#31180

GRP
#11170
#31190

GRP
#11180
#31200

■ I/O Alarm

	Alarm No.	Register No.	I/O Alarm Message
System Section	9000	00	
	9001	01	MISSING ARC GENERATION CONFIRM
	9002	02	ARC SHORTAGE
	9003	03	
	9004	04	GAS SHORTAGE (RESTART)
	9005	05	WIRE SHORTAGE (RESTART)
	9006	06	
	9007	07	
	9008	08	WELDER MALFUNCTION
	9009	09	
	9010	10	
	9011	11	
	9012	12	
	9013	13	
	9014	14	
	9015	15	
	9016	16	
	9017	17	
	9018	18	
	9019	19	
	9020	20	
9021	21		
:	:		
9063	63		
User Section	9064	64	
	9065	65	
	9066	66	
	9067	67	
	9068	68	
	9069	69	
	:	:	
	9127	127	

12 Standard Ladder Program
12.4 Arc Welding

■ I/O Message

	Register No.	I/O Message
System Section	00	
	01	WIRE STICK/ SHORT
	02	GAS SHORTAGE
	03	WIRE SHORTAGE
	04	RESTARTING FOR ARC
	05	RESTARTING FOR GAS
	06	RESTARTING FOR WIRE
	07	END OF ARC RESTARTING
	08	ARC CONFIRM RELAY STICKING
	09	ARC OCCUR AT TEST RUN
	10	VALID ONLY IN MANAGEMENT MODE (WELD ON)
	11	
	12	
	13	
	14	
	15	
	16	
	17	
	18	
	19	
	20	
	21	
:		
63		
User Section	64	
	65	
	66	
	67	
	68	
	69	
	:	
	127	

■ USER OPEN SIGNALS

Editing of system ladder is impossible, however, the seven signals which are necessary for user's operation are available. For example, wire inching can be programmed as shown below.

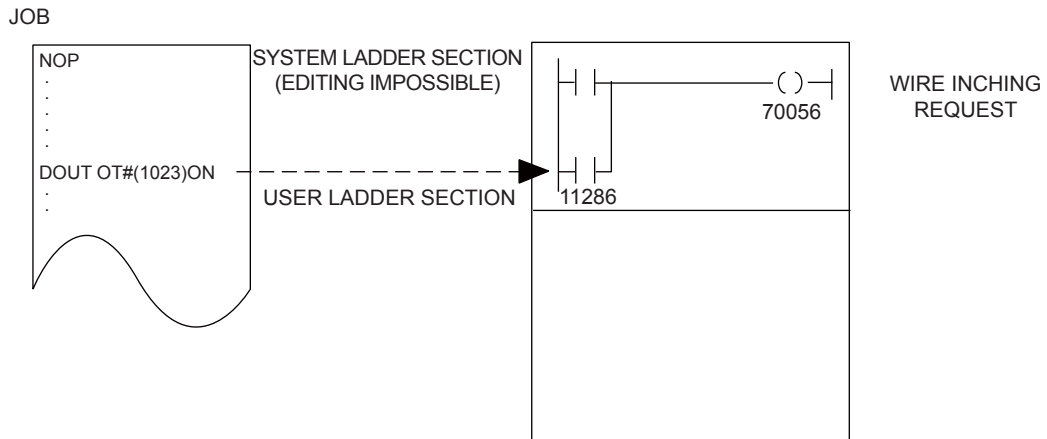

OT#1021 to OT#1024, OT#1013 to OT#1016, OT#1005 to OT#1008, OT#997 to OT#1000: USER OPEN SIGNALS

Output Number	Ladder Input Number	Meaning
OT#1021, OT#1013, OT#1005, OT#997	11284, 11274 11264, 11254	Arc shortage restart memory reset
OT#1022, OT#1014, OT#1006, OT#998	11285, 11275 11265, 11255	Restart reset
OT#1023, OT#1015, OT#1007, OT#999	11286, 11276 11266, 11256	Inching
OT#1024, OT#1016, OT#1008, OT#1000	11287, 11277 11267, 11257	Retract

OT#1021, OT#1013, OT#1005, OT#997: ARC SHORTAGE RESTART MEMORY RESET



These signals are connected to signal Nos. 70101 and 70301 in the user ladder. When these signals are on, the arc shortage restart memory signal Nos. 70100 and 70300 are reset. Use the signals to reset the memory after taking necessary action, when "1:Output error and continue operation" is selected for the arc shortage restart method. For a system with one application, use output No. 1021 and signal Nos. 70101, or 70100.

12 Standard Ladder Program

12.4 Arc Welding

70100, 70300 ARC SHORTAGE RESTART MEMORY

These signals are turned on at inadvertent arc shortage if "1: Output error and continue operation" is selected for the arc shortage restart method. When these signals are turned on, a message "END OF ARC RESTARTING" is displayed on the programming pendant. Use the signals to check arc shortage during operation.

OT#1022, OT#1014, OT#1006, OT#998: RESTART RESET



These signals are connected to signal Nos. 40583, 40643, 40703, and 40763 in the user ladder. When these signals are on, restarting is cancelled. Use the signals to cancel restarting when "manual intervention" is selected for the restarting method. For a system with one application, use OT#1022 and signal No. 40583.

OT#1023 to OT#1024, OT#1015 to OT#1016, OT#1007 to OT#1008, OT#999 to OT#1000: WIRE OPERATION



These signals are connected in the system ladder. When these signals are on, the wire operation output to the welder is executed. Use the signals to control wire in the job. The feed speed is determined by the last welding current output value in the play-back. To control this speed, place the "ARCSET" instruction before the wire operation. For a system with one application, use output No. 1023 or 1024.

OT#11283, OT#11273, OT#11263, OT#11253: GAS FLOW CONTROL



One signal from user open signals and general outputs [#11283 (for arc 1), #11273 (for arc 2), #11263 (for arc 3), and #11253 (for arc 4)] turns ON while the [INTERLOCK]+[GAS ARCOFF] keys are pressed simultaneously.



To function gas flow control using above user open signals, the above general outputs need to be assigned to external output signals by concurrent I/O ladder so that the signals can be connected to the welder's input signals for gas flow control. An example of connection with one of the YASKAWA's digital welder MOTOWELD-E series is shown below:

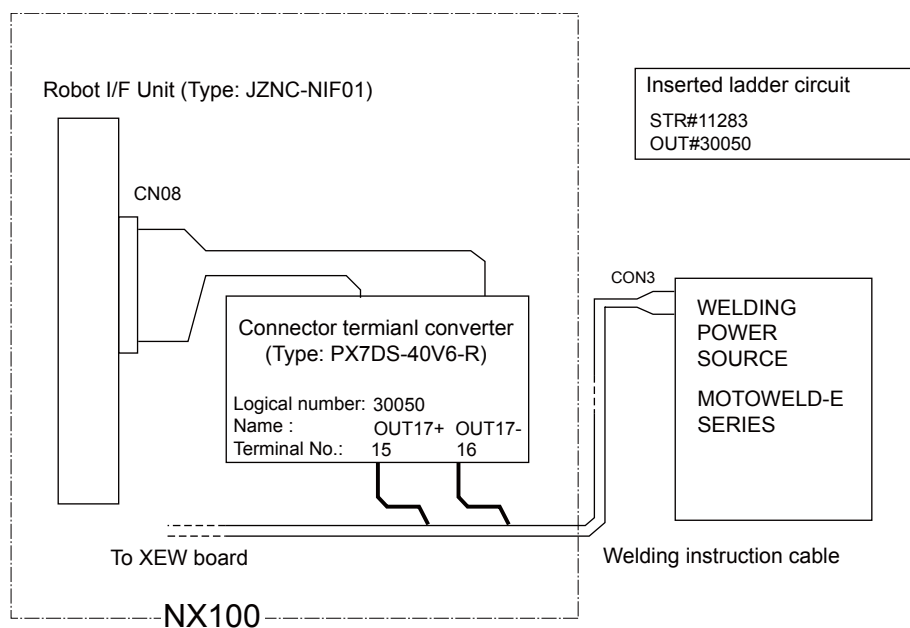

12.5 Handling

■ LADDER PROGRAM LIST

System Ladder Section

Standard ladders are prepared for each application prior to shipment. Ladder programs cannot be edited.

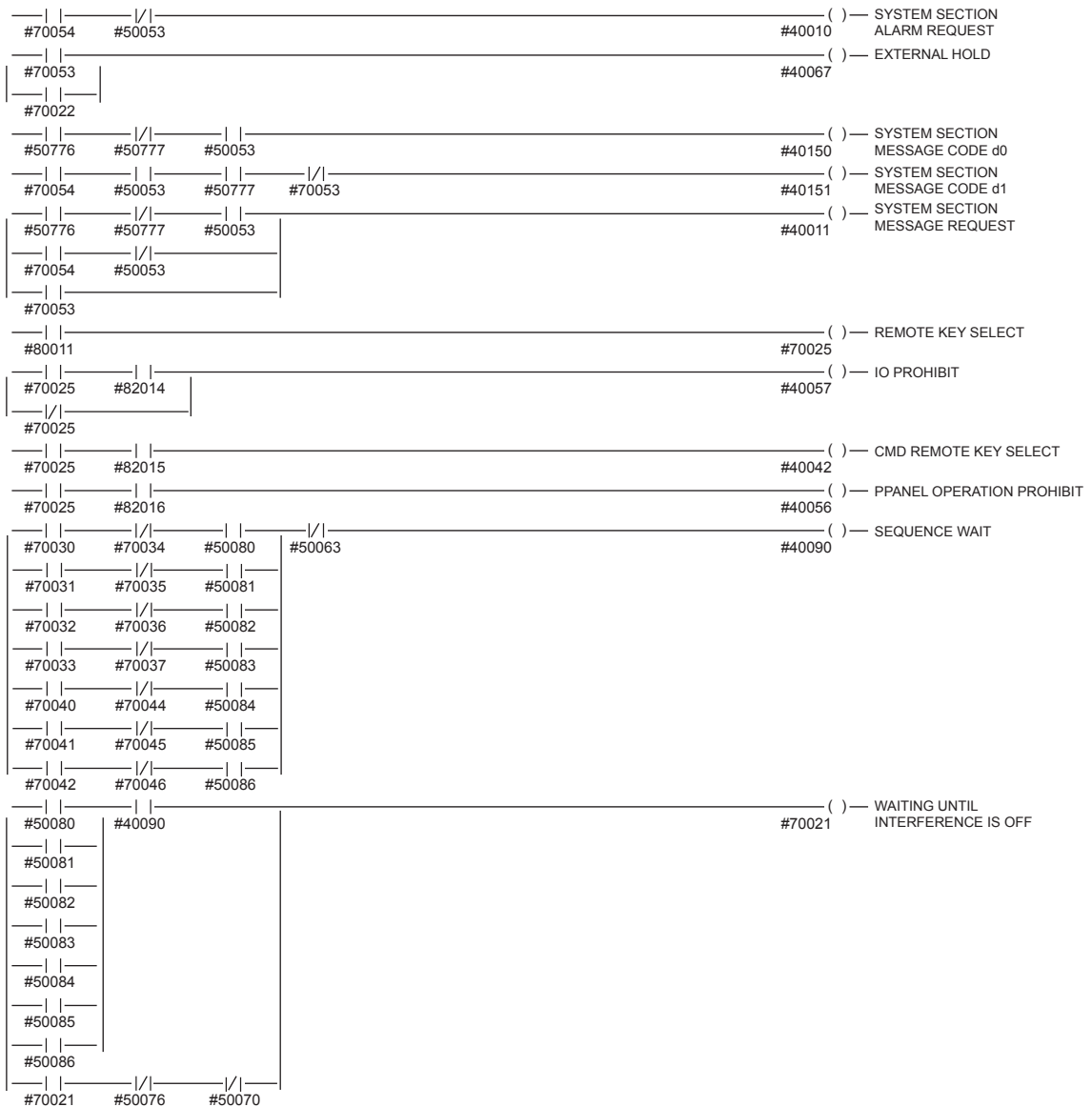

12 Standard Ladder Program

12.5 Handling

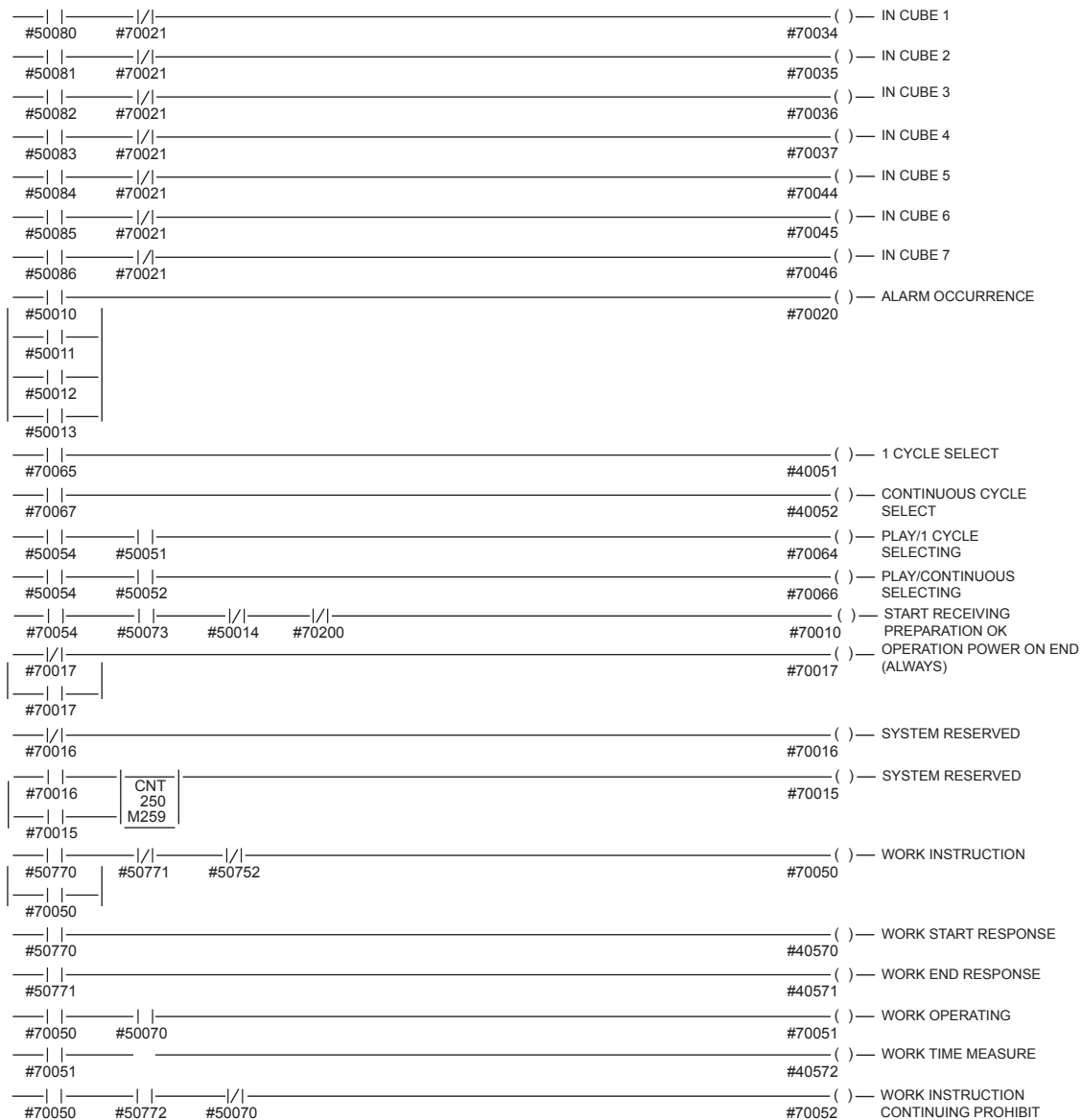

User Ladder Section

Signal connection specification and interface signals with system ladder are prepared prior to shipment. Including these signals, ladder programs can be edited.

#20010	#50073	()	EXTERNAL START
		#40044	
#20012		()	MASTER JOB CALL
		#40030	
#20013		()	ALARM/ERROR RESET
		#40014	
#20015		()	PLAY MODE SELECT
		#40041	
#20016		()	TEACH MODE SELECT
		#40040	
#20020		()	INTERFERENCE 1 ENTRANCE PROHIBIT
		#70030	
#20021		()	INTERFERENCE 2 ENTRANCE PROHIBIT
		#70031	
#20050		()	SENSOR INPUT 1
		#40580	
#20051		()	SENSOR INPUT 2
		#40581	
#20052		()	SENSOR INPUT 3
		#40582	
#20053		()	SENSOR INPUT 4
		#40583	
#20054		()	SENSOR INPUT 5
		#40584	
#20055		()	SENSOR INPUT 6
		#40585	
#20056		()	SENSOR INPUT 7
		#40586	
#20057		()	SENSOR INPUT 8
		#40587	
#50777	#50776	#20026	()
			SHOCK SENSOR INPUT
#50053		#70053	
#20027		()	AIR PRESSURE DECREASE INPUT
		#70054	
#50070		()	OPERATING
		#30010	
#50073		()	SERVO ON
		#30011	
#50020		()	TOP MASTER JOB
		#30012	
#70020		()	ALARM/ERROR OCCURRENCE
		#30013	
#50014			
#50015		()	BATTERY ALARM
		#30014	
#50016			
#40057		()	REMOTE MODE SELECTING
		#30015	
#50056			
#50054		()	PLAY MODE SELECTING
		#30016	
#50053		()	TEACH MODE SELECTING
		#30017	
#70034		()	IN CUBE 1
		#30020	
#70035		()	IN CUBE 2
		#30021	
#50117		()	WORK HOME POSITION (IN CUBE 32)
		#30022	
#50220		()	SEQUENCE EXECUTING
		#30023	
#50780		()	TOOL VALVE 1-1
		#30050	
#50781		()	TOOL VALVE 1-2
		#30051	
#50782		()	TOOL VALVE 2-1
		#30052	
#50783		()	TOOL VALVE 2-2
		#30053	
#50784		()	TOOL VALVE 3-1
		#30054	
#50785		()	TOOL VALVE 3-2
		#30055	

12 Standard Ladder Program

12.5 Handling

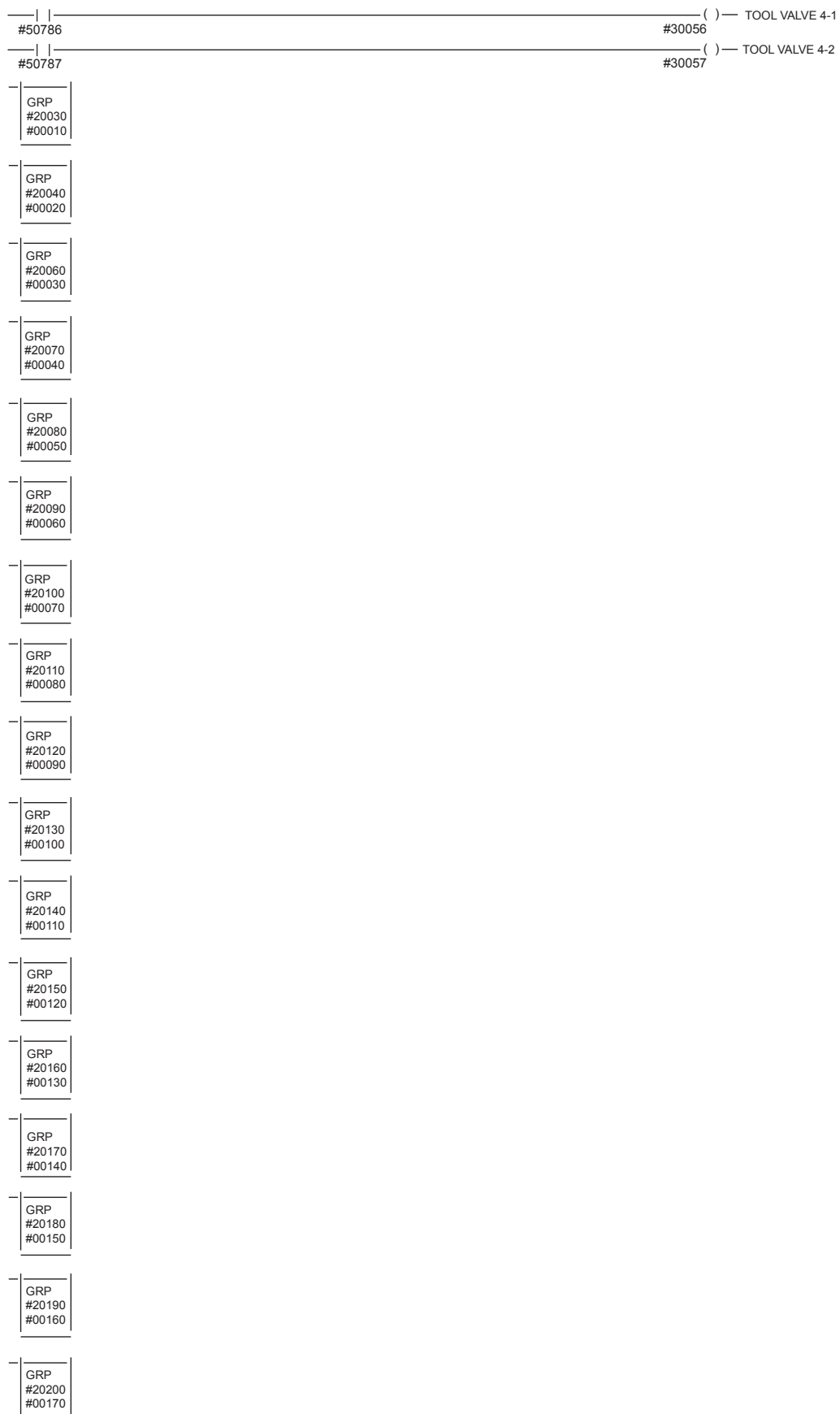

GRP
#20210
#00180

GRP
#20220
#00190

GRP
#20230
#00200

GRP
#20240
#00210

GRP
#20250
#00220

GRP
#20260
#00230

GRP
#20270
#00240

GRP
#20280
#00250

GRP
#20290
#00260

GRP
#20300
#00270

GRP
#20310
#00280

GRP
#20320
#00290

GRP
#20330
#00300

GRP
#20340
#00310

GRP
#20350
#00320

GRP
#20360
#00330

GRP
#20370
#00340

GRP
#20380
#00350

12 Standard Ladder Program

12.5 Handling

GRP
#20390
#00360

GRP
#20400
#00370

GRP
#20410
#00380

GRP
#20420
#00390

GRP
#20430
#00400

GRP
#20440
#00410

GRP
#20450
#00420

GRP
#20460
#00430

GRP
#20470
#00440

GRP
#20480
#00450

GRP
#20490
#00460

GRP
#20500
#00470

GRP
#20510
#00480

GRP
#20520
#00490

GRP
#20530
#00500

GRP
#20540
#00510

GRP
#20550
#00520

GRP
#20560
#00530

GRP
#20570
#00540

GRP
#20580
#00550

GRP
#20590
#00560

GRP
#20600
#00570

GRP
#20610
#00580

GRP
#20620
#00590

GRP
#20630
#00600

GRP
#20640
#00610

GRP
#20650
#00620

GRP
#20660
#00630

GRP
#20670
#00640

GRP
#20680
#00650

GRP
#20690
#00660

GRP
#20700
#00670

GRP
#20710
#00680

GRP
#20720
#00690

GRP
#20730
#00700

GRP
#20740
#00710

12 Standard Ladder Program

12.5 Handling

GRP #20750 #00720
GRP #20760 #00730
GRP #20770 #00740
GRP #20780 #00750
GRP #20790 #00760
GRP #20800 #00770
GRP #20810 #00780
GRP #20820 #00790
GRP #20830 #00800
GRP #20840 #00810
GRP #20850 #00820
GRP #20860 #00830
GRP #20870 #00840
GRP #20880 #00850
GRP #20890 #00860
GRP #20900 #00870
GRP #20910 #00880
GRP #20920 #00890

- GRP
#20930
#00900
- GRP
#20940
#00910
- GRP
#20950
#00920
- GRP
#20960
#00930
- GRP
#20970
#00940
- GRP
#20980
#00950
- GRP
#20990
#00960
- GRP
#21000
#00970
- GRP
#21010
#00980
- GRP
#21020
#00990
- GRP
#21030
#01000
- GRP
#21040
#01010
- GRP
#21050
#01020
- GRP
#21060
#01030
- GRP
#21070
#01040
- GRP
#21080
#01050
- GRP
#21090
#01060
- GRP
#21100
#01070

12 Standard Ladder Program

12.5 Handling

GRP #21110 #01080
GRP #21120 #01090
GRP #21130 #01100
GRP #21140 #01110
GRP #21150 #01120
GRP #21160 #01130
GRP #21170 #01140
GRP #21180 #01150
GRP #21190 #01160
GRP #21200 #01170
GRP #21210 #01180
GRP #21220 #01190
GRP #21230 #01200
GRP #21240 #01210
GRP #21250 #01220
GRP #21260 #01230
GRP #21270 #01240
GRP #21280 #01250

GRP
#10010
#30030

GRP
#10020
#30040

GRP
#10030
#30060

GRP
#10040
#30070

GRP
#10050
#30080

GRP
#10060
#30090

GRP
#10070
#30100

GRP
#10080
#30110

GRP
#10090
#30120

GRP
#10100
#30130

GRP
#10110
#30140

GRP
#10120
#30150

GRP
#10130
#30160

GRP
#10140
#30170

GRP
#10150
#30180

GRP
#10160
#30190

GRP
#10170
#30200

GRP
#10180
#30210

12 Standard Ladder Program

12.5 Handling

GRP
#10190
#30220

GRP
#10200
#30230

GRP
#10210
#30240

GRP
#10220
#30250

GRP
#10230
#30260

GRP
#10240
#30270

GRP
#10250
#30280

GRP
#10260
#30290

GRP
#10270
#30300

GRP
#10280
#30310

GRP
#10290
#30320

GRP
#10300
#30330

GRP
#10310
#30340

GRP
#10320
#30350

GRP
#10330
#30360

GRP
#10340
#30370

GRP
#10350
#30380

GRP
#10360
#30390

- GRP
#10370
#30400
- GRP
#10380
#30410
- GRP
#10390
#30420
- GRP
#10400
#30430
- GRP
#10410
#30440
- GRP
#10420
#30450
- GRP
#10430
#30460
- GRP
#10440
#30470
- GRP
#10450
#30480
- GRP
#10460
#30490
- GRP
#10470
#30500
- GRP
#10480
#30510
- GRP
#10490
#30520
- GRP
#10500
#30530
- GRP
#10510
#30540
- GRP
#10520
#30550
- GRP
#10530
#30560
- GRP
#10540
#30570

12 Standard Ladder Program

12.5 Handling

GRP #10550 #30580
GRP #10560 #30590
GRP #10570 #30600
GRP #10580 #30610
GRP #10590 #30620
GRP #10600 #30630
GRP #10610 #30640
GRP #10620 #30650
GRP #10630 #30660
GRP #10640 #30670
GRP #10650 #30680
GRP #10660 #30690
GRP #10670 #30700
GRP #10680 #30710
GRP #10690 #30720
GRP #10700 #30730
GRP #10710 #30740
GRP #10720 #30750

GRP
#10730
#30760

GRP
#10740
#30770

GRP
#10750
#30780

GRP
#10760
#30790

GRP
#10770
#30800

GRP
#10780
#30810

GRP
#10790
#30820

GRP
#10800
#30830

GRP
#10810
#30840

GRP
#10820
#30850

GRP
#10830
#30860

GRP
#10840
#30870

GRP
#10850
#30880

GRP
#10860
#30890

GRP
#10870
#30900

GRP
#10880
#30910

GRP
#10890
#30920

GRP
#10900
#30930

12 Standard Ladder Program

12.5 Handling

GRP
#10910
#30940

GRP
#10920
#30950

GRP
#10930
#30960

GRP
#10940
#30970

GRP
#10950
#30980

GRP
#10960
#30990

GRP
#10970
#31000

GRP
#10980
#31010

GRP
#10990
#31020

GRP
#11000
#31030

GRP
#11010
#31040

GRP
#11020
#31050

GRP
#11030
#31060

GRP
#11040
#31070

GRP
#11050
#31080

GRP
#11060
#31090

GRP
#11070
#31100

GRP
#11080
#31110

- GRP
#11090
#31120
- GRP
#11100
#31130
- GRP
#11110
#31140
- GRP
#11120
#31150
- GRP
#11130
#31160
- GRP
#11140
#31170
- GRP
#11150
#31180
- GRP
#11160
#31190
- GRP
#11170
#31200
- GRP
#11180
#31210
- GRP
#11190
#31220
- GRP
#11200
#31230
- GRP
#11210
#31240
- GRP
#11220
#31250
- GRP
#11230
#31260
- GRP
#11240
#31270
- GRP
#11250
#31280

12 Standard Ladder Program
12.5 Handling

■ I/O ALARM

	Alarm No.	Register No.	I/O Alarm Message
System Section	9000	00	AIR PRESSURE LOWERED
	9001	01	
	9002	02	
	9003	03	
	9004	04	
	9005	05	
	9006	06	
	9007	07	
	9008	08	
	9009	09	
	9010	10	
	9011	11	
	9012	12	
	9013	13	
	9014	14	
	9015	15	
	9016	16	
	9017	17	
	9018	18	
	9019	19	
	9020	20	
9021	21		
:	:		
9063	63		
User Section	9064	64	
	9065	65	
	9066	66	
	9067	67	
	9068	68	
	9069	69	
	:	:	
	9127	127	

■ I/O Message

	Register No.	I/O Message
System Section	00	TOOL SHOCK SENSOR WORKING
	01	TOOL SHOCK SENSOR INP. RELEASING
	02	AIR PRESSURE LOWERING
	03	
	04	
	05	
	06	
	07	
	08	
	09	
	10	
	11	
	12	
	13	
	14	
	15	
	16	
	17	
	18	
	19	
	20	
21		
	:	
	63	
User Section		
	64	
	65	
	66	
	67	
	68	
	69	
		:
	123	

12 Standard Ladder Program

12.6 Spot Welding

12.6 Spot Welding

■ Ladder Program List

System Ladder Section

Standard ladders are prepared for each application prior to shipment. Ladder programs cannot be edited.

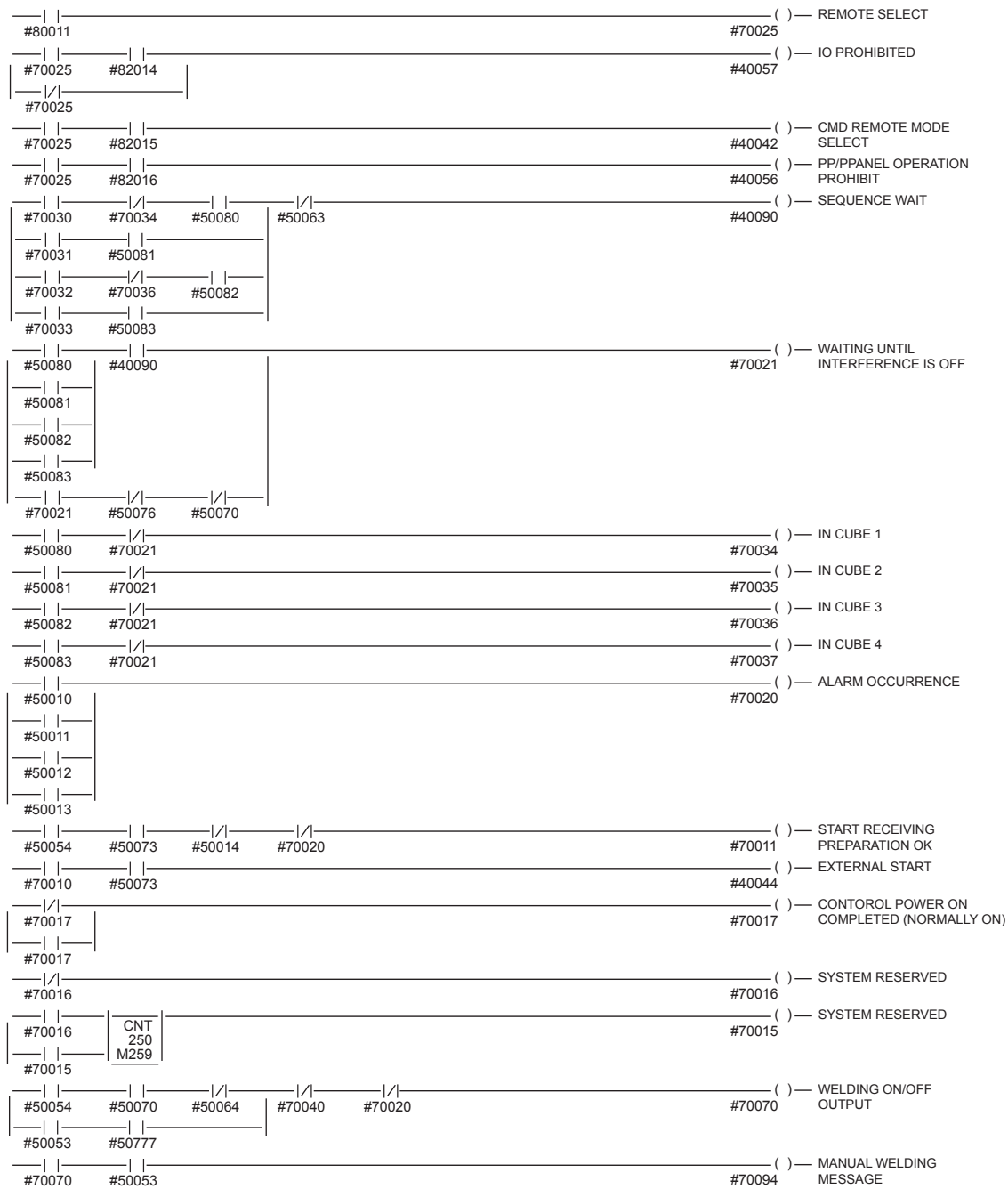

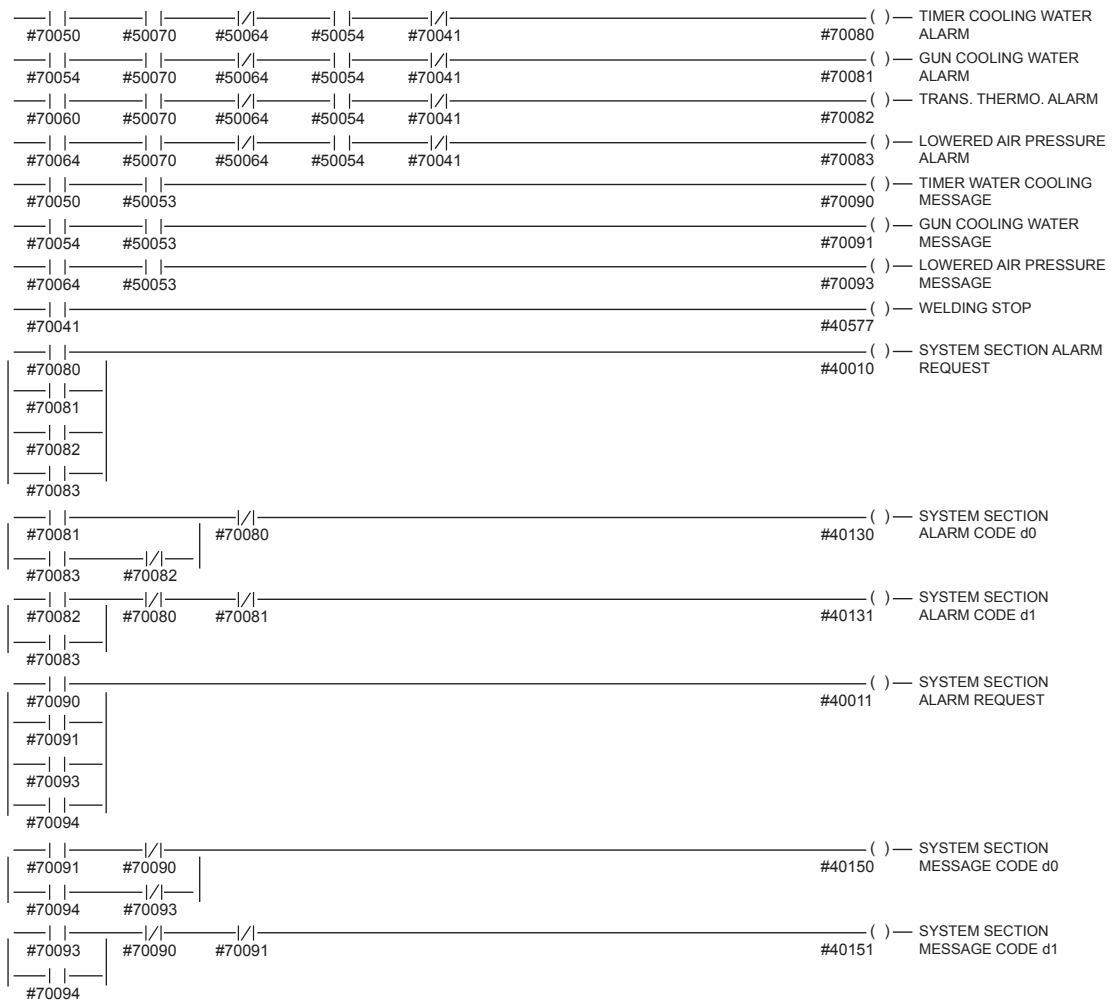

12 Standard Ladder Program

12.6 Spot Welding

User Ladder Section

Signal connection specification and interface signals with system ladder are prepared prior to shipment. Including these signals, ladder programs can be edited.

#20010			()	EXTERNAL START	#70010
#20012			()	MASTER JOB CALL	#40030
#20013			()	ALARM/ERROR RESET	#40014
#20015			()	PLAY MODE SELECT	#40041
#20016			()	TEACH MODE SELECT	#40040
#20020			()	INTERFERENCE 1 ENTRANCE PROHIBIT	#70030
#20021			()	INTERFERENCE 2 ENTRANCE PROHIBIT	#70031
#20022			()	WELD ON/OFF REQUEST	#70040
#20023			()	WELDING STOP INPUT	#70041
#20024			()	INTERFERENCE 3 ENTRANCE PROHIBIT	#70032
#20025			()	INTERFERENCE 4 ENTRANCE PROHIBIT	#70033
#50070			()	OPERATING	#30010
#50073			()	SERVO ON	#30011
#50020			()	TOP MASTER JOB	#30012
#70020			()	ALARM/ERROR OCCURRENCE	#30013
#50014					
#50015			()	BATTERY ALARM	#30014
#50016					
#40057			()	REMOTE MODE SELECTING	#30015
#50056					
#50054			()	PLAY MODE SELECTING	#30016
#50053			()	TEACH MODE SELECTING	#30017
#70034			()	IN CUBE 1	#30020
#70035			()	IN CUBE 2	#30021
#50117			()	WORK HOME POSITION (IN CUBE 32)	#30022
#50220			()	SEQUENCE EXECUTING	#30023
#70036			()	IN CUBE 3	#30024
#70037			()	IN CUBE 4	#30025
GRP #20030 #00010					
#20050	#82020	TMR M460 M250	()	ERROR INPUT OF WELD TIMER COOLING WATER	#70050
#20051	#82021	TMR M461 M251	()	ERROR INPUT OF GUN COOLING WATER	#70054
#20052	#82022		()	TRANS THERMO ERROR INPUT	#70060
#20053	#82023	TMR M462 M252	()	ERROR INPUT OF AIR PRESSURE LOW	#70064
#20050	#82020		()	IN009	#00020
#20051	#82021		()	IN010	#00021



12 Standard Ladder Program

12.6 Spot Welding

GRP
#20200
#00180

GRP
#20210
#00190

GRP
#20220
#00200

GRP
#20230
#00210

GRP
#20240
#00220

GRP
#20250
#00230

GRP
#20260
#00240

GRP
#20270
#00250

GRP
#20280
#00260

GRP
#20290
#00270

GRP
#20300
#00280

GRP
#20310
#00290

GRP
#20320
#00300

GRP
#20330
#00310

GRP
#20340
#00320

GRP
#20350
#00330

GRP
#20360
#00340

GRP
#20370
#00350

GRP
#20380
#00360

GRP
#20390
#00370

GRP
#20400
#00380

GRP
#20410
#00390

GRP
#20420
#00400

GRP
#20430
#00410

GRP
#20440
#00420

GRP
#20450
#00430

GRP
#20460
#00440

GRP
#20470
#00450

GRP
#20480
#00460

GRP
#20490
#00470

GRP
#20500
#00480

GRP
#20510
#00490

GRP
#20520
#00500

GRP
#20530
#00510

GRP
#20540
#00520

GRP
#20550
#00530

12 Standard Ladder Program

12.6 Spot Welding

GRP #20560 #00540
GRP #20570 #00550
GRP #20580 #00560
GRP #20590 #00570
GRP #20600 #00580
GRP #20610 #00590
GRP #20620 #00600
GRP #20630 #00610
GRP #20640 #00620
GRP #20650 #00630
GRP #20660 #00640
GRP #20670 #00650
GRP #20680 #00660
GRP #20690 #00670
GRP #20700 #00680
GRP #20710 #00690
GRP #20720 #00700
GRP #20730 #00710

GRP
#20740
#00720

GRP
#20750
#00730

GRP
#20760
#00740

GRP
#20770
#00750

GRP
#20780
#00760

GRP
#20790
#00770

GRP
#20800
#00780

GRP
#20810
#00790

GRP
#20820
#00800

GRP
#20830
#00810

GRP
#20840
#00820

GRP
#20850
#00830

GRP
#20860
#00840

GRP
#20870
#00850

GRP
#20880
#00860

GRP
#20890
#00870

GRP
#20900
#00880

GRP
#20910
#00890

12 Standard Ladder Program

12.6 Spot Welding

GRP
#20920
#00900

GRP
#20930
#00910

GRP
#20940
#00920

GRP
#20950
#00930

GRP
#20960
#00940

GRP
#20970
#00950

GRP
#20980
#00960

GRP
#20990
#00970

GRP
#21000
#00980

GRP
#21010
#00990

GRP
#21020
#01000

GRP
#21030
#01010

GRP
#21040
#01020

GRP
#21050
#01030

GRP
#21060
#01040

GRP
#21070
#01050

GRP
#21080
#01060

GRP
#21090
#01070

GRP
#21100
#01080

GRP
#21110
#01090

GRP
#21120
#01100

GRP
#21130
#01110

GRP
#21140
#01120

GRP
#21150
#01130

GRP
#21160
#01140

GRP
#21170
#01150

GRP
#21180
#01160

GRP
#21190
#01170

GRP
#21200
#01180

GRP
#21210
#01190

GRP
#21220
#01200

GRP
#21230
#01210

GRP
#21240
#01220

GRP
#21250
#01230

GRP
#21260
#01240

GRP
#21270
#01250

12 Standard Ladder Program
 12.6 Spot Welding

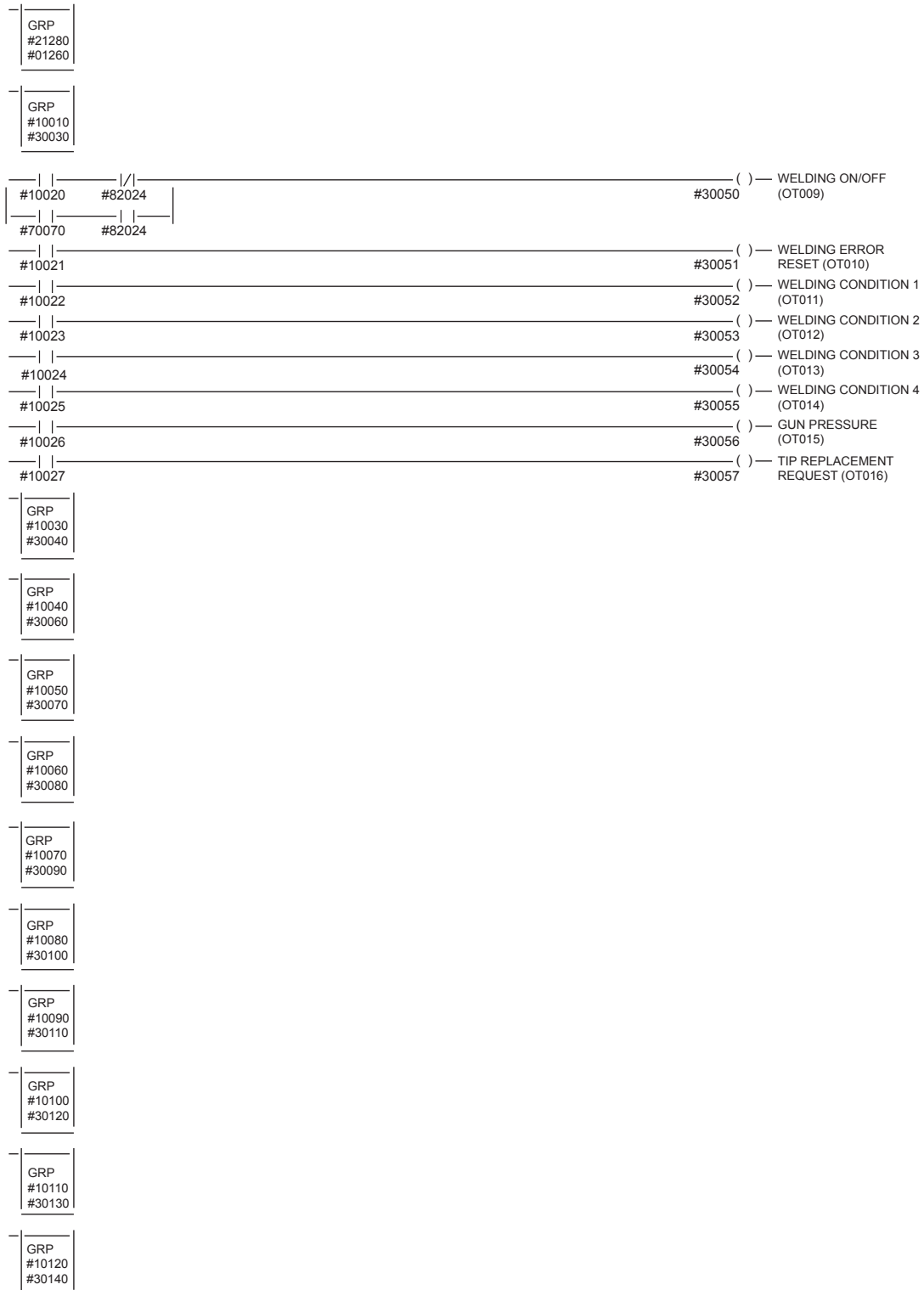

GRP
#10150
#30170

GRP
#10160
#30180

GRP
#10170
#30190

GRP
#10180
#30200

GRP
#10190
#30210

GRP
#10200
#30220

GRP
#10210
#30230

GRP
#10220
#30240

GRP
#10230
#30250

GRP
#10240
#30260

GRP
#10250
#30270

GRP
#10260
#30280

GRP
#10270
#30290

GRP
#10280
#30300

12 Standard Ladder Program

12.6 Spot Welding

GRP
#10290
#30310

GRP
#10300
#30320

GRP
#10310
#30330

GRP
#10320
#30340

GRP
#10330
#30350

GRP
#10340
#30360

GRP
#10350
#30370

GRP
#10360
#30380

GRP
#10370
#30390

GRP
#10380
#30400

GRP
#10390
#30410

GRP
#10400
#30420

GRP
#10410
#30430

GRP
#10420
#30440

GRP
#10430
#30450

GRP
#10440
#30460

GRP
#10450
#30470

GRP
#10460
#30480

GRP
#10470
#30490

GRP
#10480
#30500

GRP
#10490
#30510

GRP
#10500
#30520

GRP
#10510
#30530

GRP
#10520
#30540

GRP
#10530
#30550

GRP
#10540
#30560

GRP
#10550
#30570

GRP
#10560
#30580

GRP
#10570
#30590

GRP
#10580
#30600

GRP
#10590
#30610

GRP
#10600
#30620

GRP
#10610
#30630

GRP
#10620
#30640

GRP
#10630
#30650

GRP
#10640
#30660

12 Standard Ladder Program

12.6 Spot Welding

GRP #10650 #30670
GRP #10660 #30680
GRP #10670 #30690
GRP #10680 #30700
GRP #10690 #30710
GRP #10700 #30720
GRP #10710 #30730
GRP #10720 #30740
GRP #10730 #30750
GRP #10740 #30760
GRP #10750 #30770
GRP #10760 #30780
GRP #10770 #30790
GRP #10780 #30800
GRP #10790 #30810
GRP #10800 #30820
GRP #10810 #30830
GRP #10820 #30840

GRP
#10830
#30850

GRP
#10840
#30860

GRP
#10850
#30870

GRP
#10860
#30880

GRP
#10870
#30890

GRP
#10880
#30900

GRP
#10890
#30910

GRP
#10900
#30920

GRP
#10910
#30930

GRP
#10920
#30940

GRP
#10930
#30950

GRP
#10940
#30960

GRP
#10950
#30970

GRP
#10960
#30980

GRP
#10970
#30990

GRP
#10980
#31000

GRP
#10990
#31010

GRP
#11000
#31020

12 Standard Ladder Program

12.6 Spot Welding

GRP
#11010
#31030

GRP
#11020
#31040

GRP
#11030
#31050

GRP
#11040
#31060

GRP
#11050
#31070

GRP
#11060
#31080

GRP
#11070
#31090

GRP
#11080
#31100

GRP
#11090
#31110

GRP
#11100
#31120

GRP
#11110
#31130

GRP
#11120
#31140

GRP
#11130
#31150

GRP
#11140
#31160

GRP
#11150
#31170

GRP
#11160
#31180

GRP
#11170
#31190

GRP
#11180
#31200

GRP
#11190
#31210

GRP
#11200
#31220

GRP
#11210
#31230

GRP
#11220
#31240

GRP
#11230
#31250

GRP
#11240
#31260

GRP
#11250
#31270

GRP
#11260
#31280

12 Standard Ladder Program
12.6 Spot Welding

■ I/O Alarm

	Alarm No.	Register No.	I/O Alarm Message
System Section	9000	00	ERR OF WELD TIMER COOLING WATER
	9001	01	ERROR OF GUN COOLING WATER
	9002	02	ERROR IN TRANSTHERMO OF GUN
	9003	03	AIR PRESSURE LOWERED
	9004	04	
	9005	05	
	9006	06	
	9007	07	
	9008	08	
	9009	09	
	9010	10	
	9011	11	
	9012	12	
	9013	13	
	9014	14	
	9015	15	
	9016	16	
	9017	17	
	9018	18	
	9019	19	
	9020	20	
9021	21		
:	:		
9063	63		
User Section	9064	64	
	9065	65	
	9066	66	
	9067	67	
	9068	68	
	9069	69	
	:	:	
	9127	127	

■ I/O Message

	Register No.	I/O Message	
System Section	00	ERR OF WELD TIMER COOLING WATER	
	01	ERROR OF GUN COOLING WATER	
	02	AIR PRESSURE LOWERING	
	03	AVAILABLE TO MANUAL SPOT WELDING	
	04		
	05		
	06		
	07		
	08		
	09		
	10		
	11		
	12		
	13		
	14		
	15		
	16		
	17		
	18		
	19		
	20		
21			
	:		
	63		
User Section			
	64		
	65		
	66		
	67		
	68		
	69		
		:	
		127	

12.7 General-Purpose Applications

■ LADDER PROGRAM LIST

System Ladder Section

Standard ladders are prepared for each application prior to shipment. Ladder programs cannot be edited.

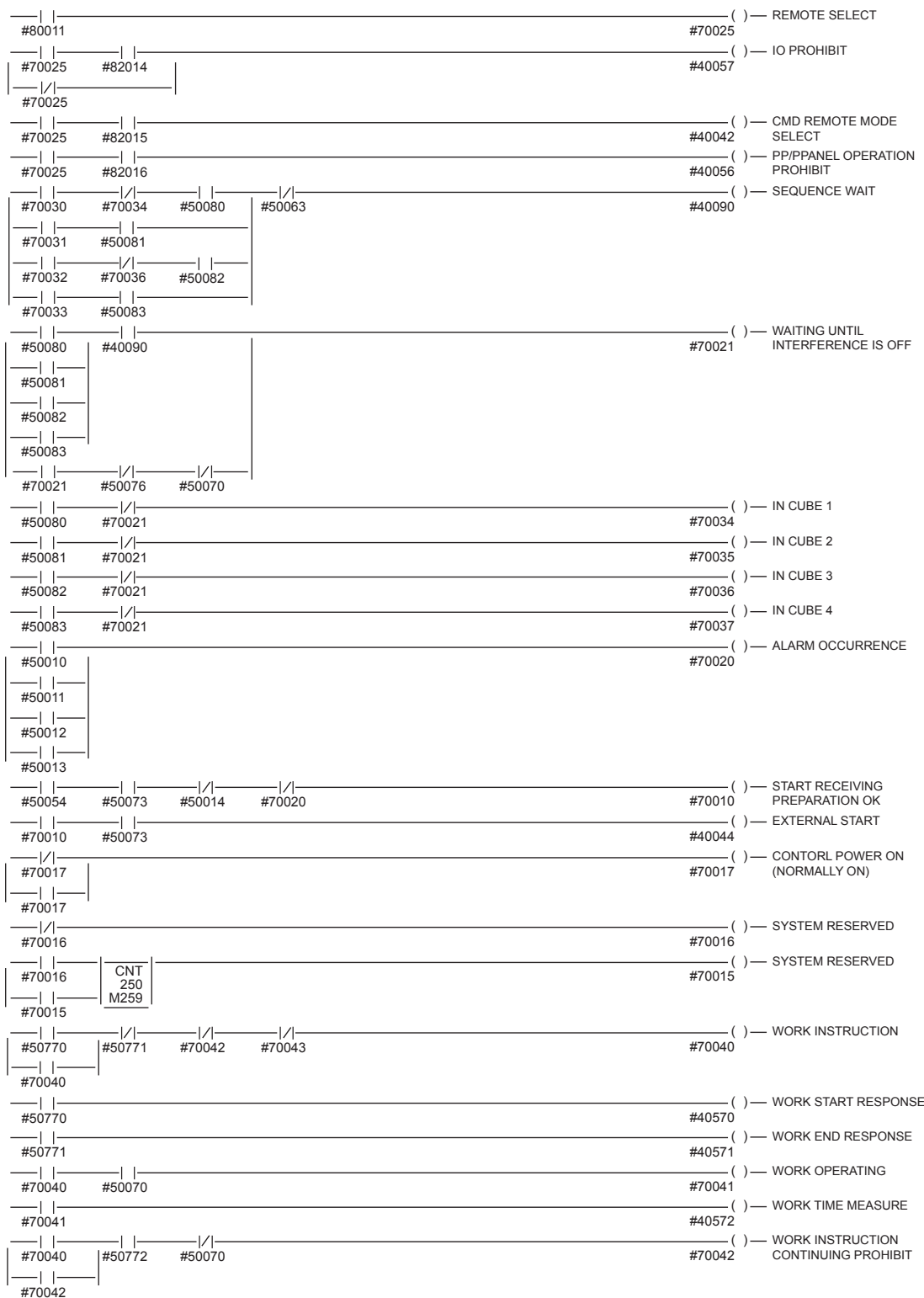

User Ladder Section

Signal connection specification and interface signals with system ladder are prepared prior to shipment. Including these signals, ladder programs can be edited.

—	—	() — EXTERNAL START
#20010	#70010	
—	—	() — MASTER JOB CALL
#20012	#40030	
—	—	() — ALARM/ERROR RESET
#20013	#40014	
—	—	() — PLAY MODE SELECT
#20015	#40041	
—	—	() — TEACH MODE SELECT
#20016	#40040	
—	—	() — INTERFERENCE 1 ENTRANCE PROHIBIT
#20020	#70030	
—	—	() — INTERFERENCE 2 ENTRANCE PROHIBIT
#20021	#70031	
—	—	() — WORK PROHIBIT
#20022	#70043	
—	—	() — INTERFERENCE 3 ENTRANCE PROHIBIT
#20024	#70032	
—	—	() — INTERFERENCE 4 ENTRANCE PROHIBIT
#20025	#70033	
—	—	() — OPERATING
#50070	#30010	
—	—	() — SERVO ON
#50073	#30011	
—	—	() — TOP MASTER JOB
#50020	#30012	
—	—	() — ALARM/ERROR OCCURRENCE
#70020	#30013	
—	—	() — BATTERY ALARM
#50014	#30014	
—	—	() — REMOTE MODE SELECTING
#50015	#30015	
—	—	() — PLAY MODE SELECTING
#50016	#30016	
—	—	() — TEACH MODE SELECTING
#40057	#30017	
—	—	() — IN CUBE 1
#50056	#30020	
—	—	() — IN CUBE 2
#50054	#30021	
—	—	() — WORK HOME POSITION (IN CUBE 32)
#50053	#30022	
—	—	() — SEQUENCE EXECUTING
#70034	#30023	
—	—	() — IN CUBE 3
#70035	#30024	
—	—	() — IN CUBE 4
#50117	#30025	
—	—	() — WORK INSTRUCTION
#50220	#30026	
—	—	
#70036		
—	—	
#70037		
—	—	
#70040		
—	—	
GRP		
#20030		
#00010		
—	—	
GRP		
#20040		
#00020		
—	—	
GRP		
#20050		
#00030		
—	—	
GRP		
#20060		
#00040		
—	—	
GRP		
#20070		
#00050		

12 Standard Ladder Program

12.7 General-Purpose Applications

GRP
#20080
#00060

GRP
#20090
#00070

GRP
#20100
#00080

GRP
#20110
#00090

GRP
#20120
#00100

GRP
#20130
#00110

GRP
#20140
#00120

GRP
#20150
#00130

GRP
#20160
#00140

GRP
#20170
#00150

GRP
#20180
#00160

GRP
#20190
#00170

GRP
#20200
#00180

GRP
#20210
#00190

GRP
#20220
#00200

GRP
#20230
#00210

GRP
#20240
#00220

GRP
#20250
#00230

GRP
#20260
#00240

GRP
#20270
#00250

GRP
#20280
#00260

GRP
#20290
#00270

GRP
#20300
#00280

GRP
#20310
#00290

GRP
#20320
#00300

GRP
#20330
#00310

GRP
#20340
#00320

GRP
#20350
#00330

GRP
#20360
#00340

GRP
#20370
#00350

GRP
#20380
#00360

GRP
#20390
#00370

GRP
#20400
#00380

GRP
#20410
#00390

GRP
#20420
#00400

GRP
#20430
#00410

12 Standard Ladder Program

12.7 General-Purpose Applications

GRP
#20440
#00420

GRP
#20450
#00430

GRP
#20460
#00440

GRP
#20470
#00450

GRP
#20480
#00460

GRP
#20490
#00470

GRP
#20500
#00480

GRP
#20510
#00490

GRP
#20520
#00500

GRP
#20530
#00510

GRP
#20540
#00520

GRP
#20550
#00530

GRP
#20560
#00540

GRP
#20570
#00550

GRP
#20580
#00560

GRP
#20590
#00570

GRP
#20600
#00580

GRP
#20610
#00590

GRP #20620 #00600
GRP #20630 #00610
GRP #20640 #00620
GRP #20650 #00630
GRP #20660 #00640
GRP #20670 #00650
GRP #20680 #00660
GRP #20690 #00670
GRP #20700 #00680
GRP #20710 #00690
GRP #20720 #00700
GRP #20730 #00710
GRP #20740 #00720
GRP #20750 #00730
GRP #20760 #00740
GRP #20770 #00750
GRP #20780 #00760
GRP #20790 #00770

12 Standard Ladder Program

12.7 General-Purpose Applications

GRP
#20800
#00780

GRP
#20810
#00790

GRP
#20820
#00800

GRP
#20830
#00810

GRP
#20840
#00820

GRP
#20850
#00830

GRP
#20860
#00840

GRP
#20870
#00850

GRP
#20880
#00860

GRP
#20890
#00870

GRP
#20900
#00880

GRP
#20910
#00890

GRP
#20920
#00900

GRP
#20930
#00910

GRP
#20940
#00920

GRP
#20950
#00930

GRP
#20960
#00940

GRP
#20970
#00950

GRP
#20980
#00960

GRP
#20990
#00970

GRP
#21000
#00980

GRP
#21010
#00990

GRP
#21020
#01000

GRP
#21030
#01010

GRP
#21040
#01020

GRP
#21050
#01030

GRP
#21060
#01040

GRP
#21070
#01050

GRP
#21080
#01060

GRP
#21090
#01070

GRP
#21100
#01080

GRP
#21110
#01090

GRP
#21120
#01100

GRP
#21130
#01110

GRP
#21140
#01120

GRP
#21150
#01130

12 Standard Ladder Program

12.7 General-Purpose Applications

GRP
#21160
#01140

GRP
#21170
#01150

GRP
#21180
#01160

GRP
#21190
#01170

GRP
#21200
#01180

GRP
#21210
#01190

GRP
#21220
#01200

GRP
#21230
#01210

GRP
#21240
#01220

GRP
#21250
#01230

GRP
#21260
#01240

GRP
#21270
#01250

GRP
#21280
#01260

GRP
#10010
#30030

GRP
#10020
#30040

GRP
#10030
#30050

GRP
#10040
#30060

GRP
#10050
#30070

GRP #10060 #30080
GRP #10070 #30090
GRP #10080 #30100
GRP #10090 #30110
GRP #10100 #30120
GRP #10110 #30130
GRP #10120 #30140
GRP #10130 #30150
GRP #10140 #30160
GRP #10150 #30170
GRP #10160 #30180
GRP #10170 #30190
GRP #10180 #30200
GRP #10190 #30210
GRP #10200 #30220
GRP #10210 #30230
GRP #10220 #30240
GRP #10230 #30250

12 Standard Ladder Program

12.7 General-Purpose Applications

GRP
#10240
#30260

GRP
#10250
#30270

GRP
#10260
#30280

GRP
#10270
#30290

GRP
#10280
#30300

GRP
#10290
#30310

GRP
#10300
#30320

GRP
#10310
#30330

GRP
#10320
#30340

GRP
#10330
#30350

GRP
#10340
#30360

GRP
#10350
#30370

GRP
#10360
#30380

GRP
#10370
#30390

GRP
#10380
#30400

GRP
#10390
#30410

GRP
#10400
#30420

GRP
#10410
#30430

GRP #10420 #30440
GRP #10430 #30450
GRP #10440 #30460
GRP #10450 #30470
GRP #10460 #30480
GRP #10470 #30490
GRP #10480 #30500
GRP #10490 #30510
GRP #10500 #30520
GRP #10510 #30530
GRP #10520 #30540
GRP #10530 #30550
GRP #10540 #30560
GRP #10550 #30570
GRP #10560 #30580
GRP #10570 #30590
GRP #10580 #30600
GRP #10590 #30610

12 Standard Ladder Program

12.7 General-Purpose Applications

GRP
#10600
#30620

GRP
#10610
#30630

GRP
#10620
#30640

GRP
#10630
#30650

GRP
#10640
#30660

GRP
#10650
#30670

GRP
#10660
#30680

GRP
#10670
#30690

GRP
#10680
#30700

GRP
#10690
#30710

GRP
#10700
#30720

GRP
#10710
#30730

GRP
#10720
#30740

GRP
#10730
#30750

GRP
#10740
#30760

GRP
#10750
#30770

GRP
#10760
#30780

GRP
#10770
#30790

GRP
#10780
#30800

GRP
#10790
#30810

GRP
#10800
#30820

GRP
#10810
#30830

GRP
#10820
#30840

GRP
#10830
#30850

GRP
#10840
#30860

GRP
#10850
#30870

GRP
#10860
#30880

GRP
#10870
#30890

GRP
#10880
#30900

GRP
#10890
#30910

GRP
#10900
#30920

GRP
#10910
#30930

GRP
#10920
#30940

GRP
#10930
#30950

GRP
#10940
#30960

GRP
#10950
#30970

12 Standard Ladder Program

12.7 General-Purpose Applications

GRP #10960 #30980
GRP #10970 #30990
GRP #10980 #31000
GRP #10990 #31010
GRP #11000 #31020
GRP #11010 #31030
GRP #11020 #31040
GRP #11030 #31050
GRP #11040 #31060
GRP #11050 #31070
GRP #11060 #31080
GRP #11070 #31090
GRP #11080 #31100
GRP #11090 #31110
GRP #11100 #31120
GRP #11110 #31130
GRP #11120 #31140
GRP #11130 #31150

GRP
#11140
#31160

GRP
#11150
#31170

GRP
#11160
#31180

GRP
#11170
#31190

GRP
#11180
#31200

GRP
#11190
#31210

GRP
#11200
#31220

GRP
#11210
#31230

GRP
#11220
#31240

GRP
#11230
#31250

GRP
#11240
#31260

GRP
#11250
#31270

GRP
#11260
#31280

12 Standard Ladder Program
12.7 General-Purpose Applications

■ I/O ALARM

	Alarm No.	Register No.	I/O Alarm Message
System Section	9000	00	
	9001	01	
	9002	02	
	9003	03	
	9004	04	
	9005	05	
	9006	06	
	9007	07	
	9008	08	
	9009	09	
	9010	10	
	9011	11	
	9012	12	
	9013	13	
	9014	14	
	9015	15	
	9016	16	
	9017	17	
	9018	18	
	9019	19	
	9020	20	
9021	21		
:	:		
9063	63		
User Section	9064	64	
	9065	65	
	9066	66	
	9067	67	
	9068	68	
	9069	69	
	:	:	
	9127	127	

■ I/O MESSAGE

	Register No.	I/O Message	
System Section	00		
	01		
	02		
	03		
	04		
	05		
	06		
	07		
	08		
	09		
	10		
	11		
	12		
	13		
	14		
	15		
	16		
	17		
	18		
	19		
	20		
21			
	:		
	63		
User Section	64		
	65		
	66		
	67		
	68		
	69		
		:	
		127	

13 How to Monitor Signals

Signal status can be monitored in the windows described in the following sections.

13.1 Monitoring I/O Signals

The following example shows one of the I/O monitor windows.

13.1.1 I/O Windows

	Operation	Explanation																				
1	Select {IN/OUT} under the main menu.																					
2	Select an I/O window to be monitored.	<p>The following I/O windows can be selected.</p> <table border="1"> <tbody> <tr> <td>{UNIVERSAL INPUT}</td> <td>Signals referred with instructions in JOBs (#0xxxx)</td> </tr> <tr> <td>{UNIVERSAL OUTPUT}</td> <td>Signals output from JOBs (#1xxxx)</td> </tr> <tr> <td>{EXTERNAL INPUT}</td> <td>Signals input from external devices (#2xxxx)</td> </tr> <tr> <td>{EXTERNAL OUTPUT}</td> <td>Signals output to external devices (#3xxxx)</td> </tr> <tr> <td>{SPECIFIED INPUT}</td> <td>Signals change manipulator operation mode (#4xxxx)</td> </tr> <tr> <td>{SPECIFIED OUTPUT}</td> <td>Signals inform manipulator operation mode and status (#5xxxx)</td> </tr> <tr> <td>{AUX. RELAY}</td> <td>Signals used in concurrent I/O (#7xxxx)</td> </tr> <tr> <td>{CONTROL INPUT}</td> <td>Signals refer to hardware status controller (#8xxxx)</td> </tr> <tr> <td>{NETWORK INPUT}</td> <td>Signals input from network devices (#22xxx)</td> </tr> <tr> <td>{NETWORK OUTPUT}</td> <td>Signals output to network devices (#32xxx)</td> </tr> </tbody> </table>	{UNIVERSAL INPUT}	Signals referred with instructions in JOBs (#0xxxx)	{UNIVERSAL OUTPUT}	Signals output from JOBs (#1xxxx)	{EXTERNAL INPUT}	Signals input from external devices (#2xxxx)	{EXTERNAL OUTPUT}	Signals output to external devices (#3xxxx)	{SPECIFIED INPUT}	Signals change manipulator operation mode (#4xxxx)	{SPECIFIED OUTPUT}	Signals inform manipulator operation mode and status (#5xxxx)	{AUX. RELAY}	Signals used in concurrent I/O (#7xxxx)	{CONTROL INPUT}	Signals refer to hardware status controller (#8xxxx)	{NETWORK INPUT}	Signals input from network devices (#22xxx)	{NETWORK OUTPUT}	Signals output to network devices (#32xxx)
{UNIVERSAL INPUT}	Signals referred with instructions in JOBs (#0xxxx)																					
{UNIVERSAL OUTPUT}	Signals output from JOBs (#1xxxx)																					
{EXTERNAL INPUT}	Signals input from external devices (#2xxxx)																					
{EXTERNAL OUTPUT}	Signals output to external devices (#3xxxx)																					
{SPECIFIED INPUT}	Signals change manipulator operation mode (#4xxxx)																					
{SPECIFIED OUTPUT}	Signals inform manipulator operation mode and status (#5xxxx)																					
{AUX. RELAY}	Signals used in concurrent I/O (#7xxxx)																					
{CONTROL INPUT}	Signals refer to hardware status controller (#8xxxx)																					
{NETWORK INPUT}	Signals input from network devices (#22xxx)																					
{NETWORK OUTPUT}	Signals output to network devices (#32xxx)																					

The window shown below is the example of the Universal Output window, explaining how to read each signal. (The same applies to the signals on other windows.)

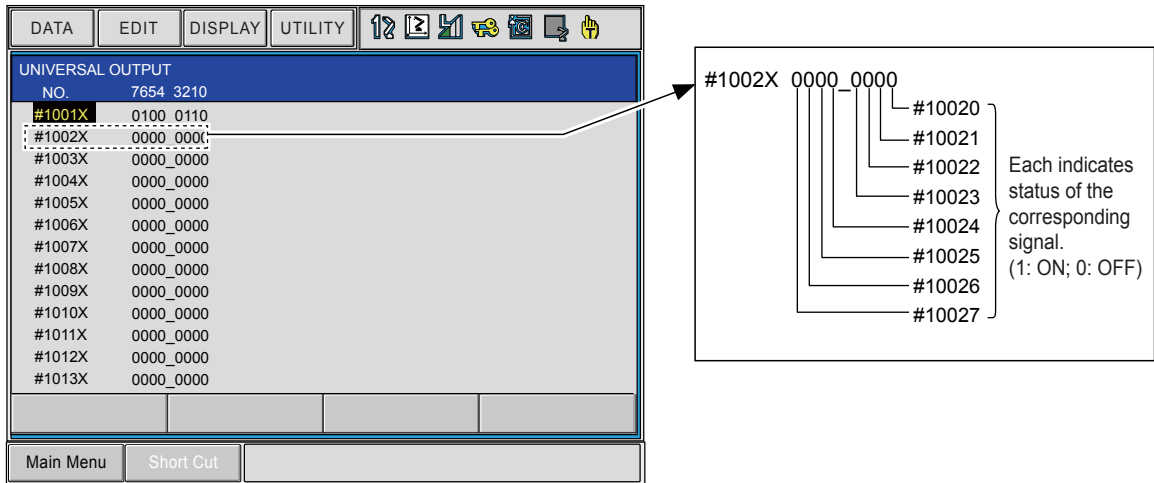

[The UNIVERSAL OUTPUT Window]

If the desired relay number is not displayed on the screen, perform the following operation to point the cursor to the desired relay number.

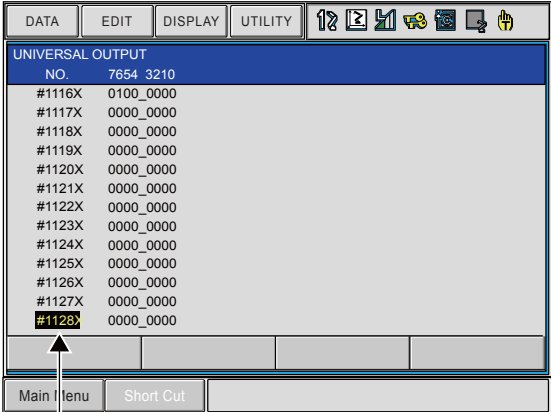

	Operation	Explanation
1	Point the cursor to the desired relay number.	<p>Move the cursor to a relay number, and press [SELECT]. Input the desired relay number with the numeric keys, then press [ENTER] to point the cursor to the specified number.</p>  <p>The cursor moved to the desired relay number.</p>

13 How to Monitor Signals

13.2 I/O Status Window

13.2 I/O Status Window

The signal status can be monitored by switching the UNIVERSAL INPUT/OUTPUT, EXTERNAL INPUT/OUTPUT, SPECIFIED INPUT/OUTPUT windows to the I/O status window. In this window, each signal name can be monitored as well.

	Operation	Explanation
1	Select {DISPLAY} under the menu.	
2	Select {DETAIL}.	The I/O window is switched to the I/O status window.
	Select {SIMPLE}.	The I/O status window is switched to the I/O window.
3	Press page key  .	<p>Pressing the page key changes the relay number displayed on the screen.</p> <p>Refer to the example below on how the UNIVERSAL OUTPUT status window displays the relay numbers.</p> <p>The relay numbers are displayed in the following order each time the page key  is pressed: #1001X → #1102X → ... → #1127X → #1128X (the last page) → #1001X → ...</p> <p>The relay numbers change in the following reverse order each time the [SHIFT] + page key  are pressed: #1001X → #1128X (the last page) → #1127X → ... → #1002X → #1001X → ...</p>

The window shown below is the example of the Universal Output window, explaining how to read each signal. (The same applies to the signals on other windows.)

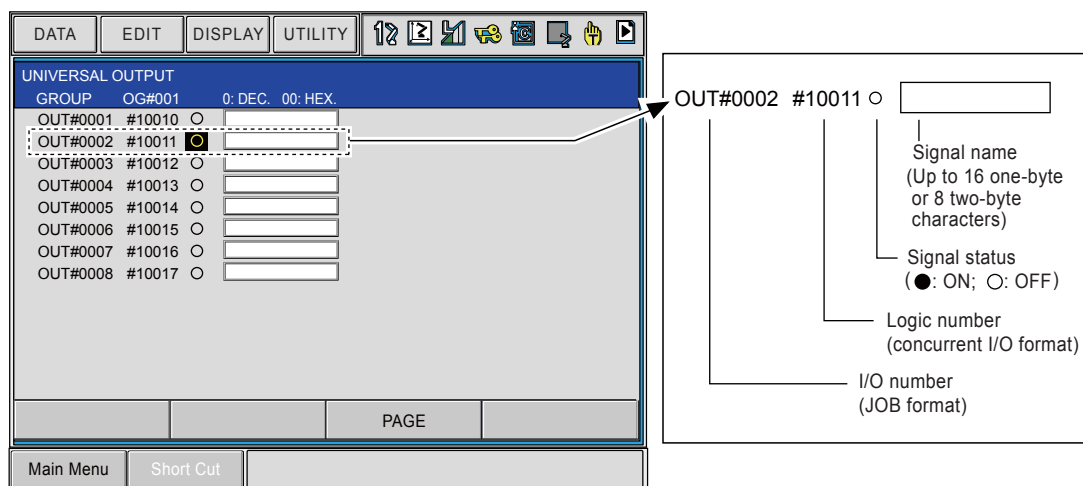

[The UNIVERSAL OUTPUT Window]

- In the Universal Output status window, the output signal on/off status can be changed. Once the status is changed, the status is maintained unless the next output instruction of JOB (DOUT) is executed.

- In the status windows "Universal Input", "External Input" and "External Output", the signal ON/OFF status can be forcibly changed. Once the status is changed, the status is maintained unless the forced change status is cancelled.

The signal name can be registered by performing the following procedure.

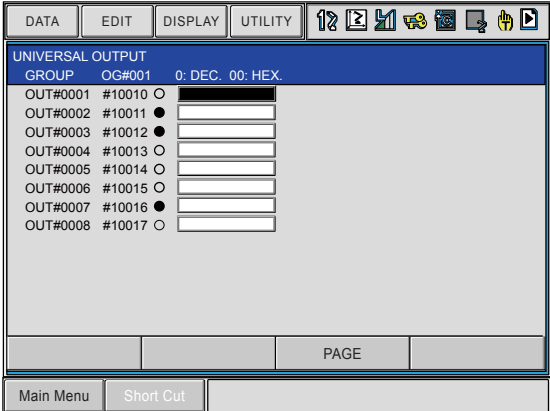
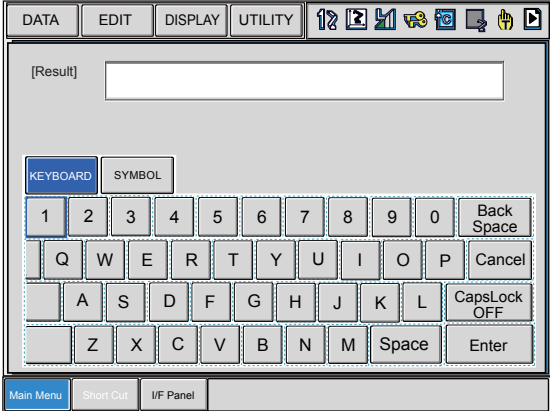
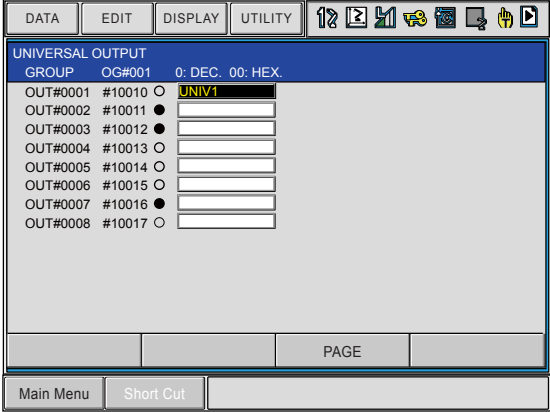
	Operation	Explanation
1	Select the signal name to be registered.	<p>Move the cursor to the desired signal name to be registered, and press [SELECT] to enable character entry. Enter up to 16 one-byte (or 8 two-byte) characters.</p>  
2	Enter the signal name.	
3	Press [ENTER].	<p>The name is registered.</p> 

13 How to Monitor Signals

13.2 I/O Status Window

13.2.1 Universal Output Window

The ON-OFF status of the universal output signals can be changed by performing the following procedure.

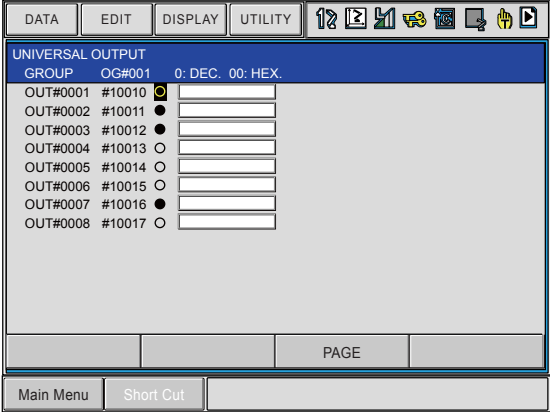
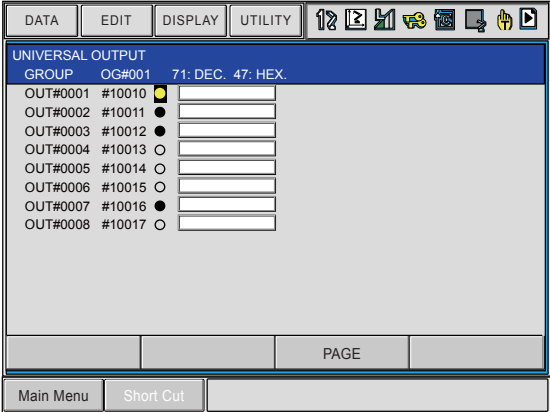
	Operation	Explanation
1	Select the signal status desired to be changed.	<p>Move the cursor to the status ("●" or "○") of desired signal in the Universal Output window.</p> 
2	Select the signal status.	<p>The signal status changes each time the [INTERLOCK] +[SELECT] keys are pressed.</p> 

13.2.2 Universal Input Window

The status of the universal input signals can be changed by performing the following procedure.

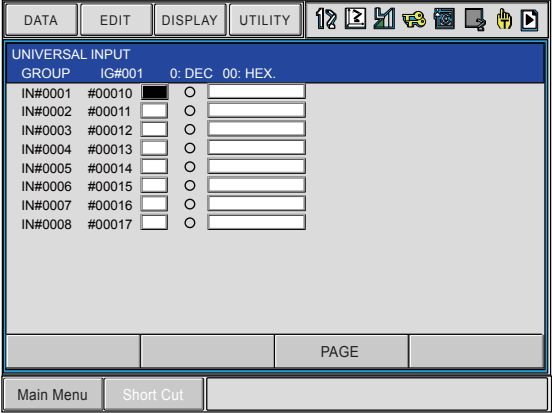
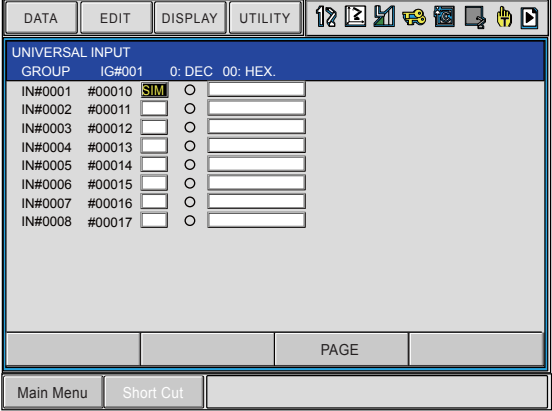
	Operation	Explanation
1	Select the signal desired to be changed.	<p>Move the cursor to the small box " <input type="checkbox"/> " on the row of the signal to be changed in the Universal Input window.</p> 
2	Select the signal status.	<p>The status changes to " <input type="checkbox"/> SIM " or " <input type="checkbox"/> " each time the [SELECT] key is pressed.</p>  <p><input type="checkbox"/> SIM : status of forced signal output <input type="checkbox"/> : standard status</p>

13 How to Monitor Signals

13.2 I/O Status Window

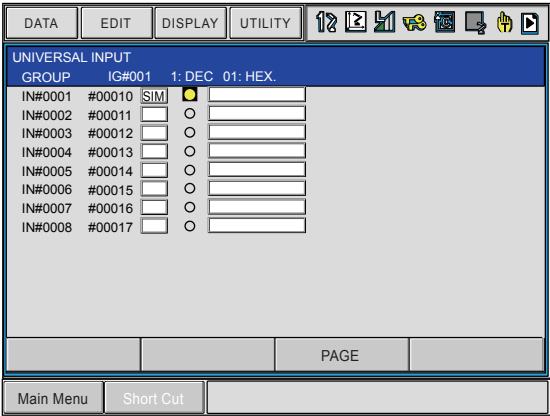
	Operation	Explanation
3	Select the signal status.	<p>Move the cursor to the status ("●" or "○") specified as "SIM". Only the signal status specified as "SIM" changes each time the [INTERLOCK] +[SELECT] keys are pressed.</p> 



- If "SIM" (forced signal output) is selected, the user parameter S2C265 enables the continuous operation of the next instruction even if the signal status does not correspond to the condition when executing the WAIT instruction that specifies the infinite wait status for the universal input signal.

(Example) When the following instruction is given in a JOB with "SIM" specified for the IN#0001.

WAIT IN#0001=ON

1. S4C265=0: infinite wait status until the signal status corresponds to the condition.
2. S4C265=non-0: executes the next instruction after a time specified in S2C265 (in units of 0.01 msec) has passed even if the signal status does not correspond to the condition.

For example, when the parameter is set to "S4C265=100", the above WAIT instruction executes the next instruction a second later if IN#0001 is set to "OFF" enabled by selecting "SIM".



- Perform the following check operation for safety when operating the manipulator with "SIM" (forced signal output) is remained selected for the universal input signal.

1. If any of the universal input signal is set to "SIM", the confirmation dialog box appears when starting a job.

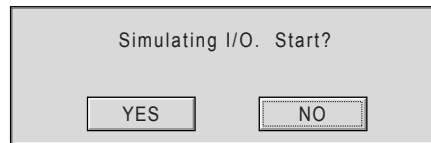

Select "YES" when executing the job in the status of the forced signal output. The job starts running by performing the start operation again after the dialog box disappears.

Select "NO" when not executing the job in the status of the forced signal output. Cancel the "SIM" status after the dialog box disappears.

2. If any of the external output signal is set to "SIM", the confirmation dialog box appears when operating the manipulator (JOG, FWD/BWD operations) with the programming pendant.

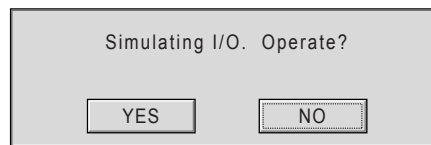

Select "YES" when operating the manipulator in the status of the forced signal output.

The manipulator can be operated after the dialog box disappears.

Select "NO" when not operating the manipulator in the status of the forced signal output.

Cancel the "SIM" status after the dialog box disappears.

- Concurrent I/O program reflects the actual signal status regardless of the "SIM" setting status of the universal input signal.

For example, even if building a circuit in the ladder program as follows, #30010 is not ON when "SIM" is selected and the signal status set to "ON" ("●") for #00010. (The ON-OFF status of normal signal is referred in the ladder program.)

```
STR #00010  
OUT #30010
```

13 How to Monitor Signals

13.2 I/O Status Window

The "SIM" status of the universal input signal can be collectively cancelled by performing the following procedure.

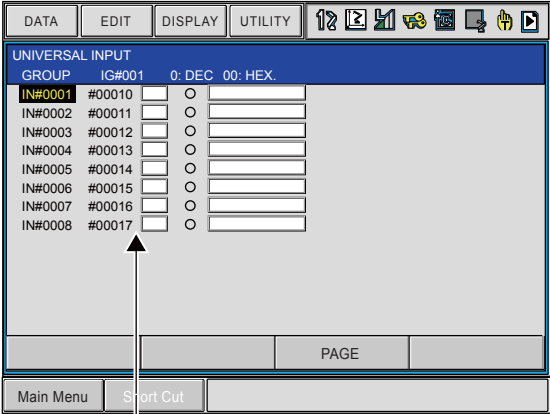
	Operation	Explanation
1	Select {EDIT} from the Menu Area.	
2	Select {SELECT ALL PHY}.	<p>The forced status (<input type="checkbox"/> SIM) of all the signals is cancelled (<input type="checkbox"/>).</p>  <p>Cancels the forced status ("SIM") of all the signals. (IN#0001 to IN#1024)</p>

13.2.3 Changing Signal Status from the External Output Window

The status of the external output signals can be changed by performing the following procedure.

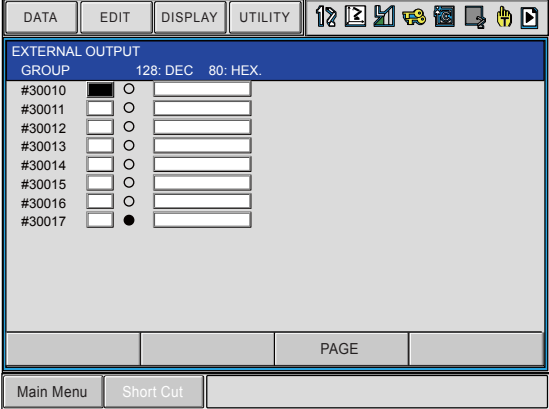
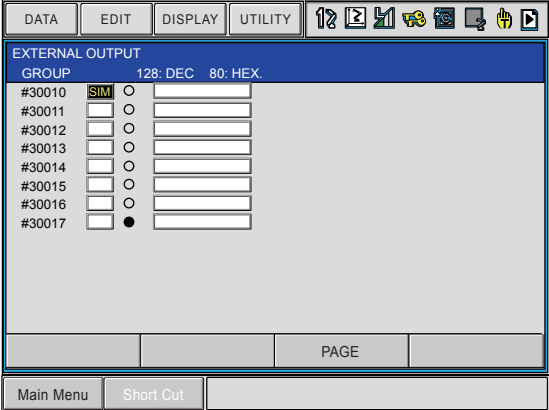
	Operation	Explanation
1	Select the signal desired to be changed.	<p>Move the cursor to the small box " <input type="checkbox"/> " on the row of the signal to be changed in the External Output window.</p>  <p>The screenshot shows the 'EXTERNAL OUTPUT' window with a menu bar (DATA, EDIT, DISPLAY, UTILITY) and a toolbar. A list of signals from #30010 to #30017 is displayed. Each signal has a small box, a radio button, and a text field. Signal #30010 has a black background on its small box and a selected radio button. Signal #30017 has a selected radio button. A 'PAGE' button is at the bottom right, and 'Main Menu' and 'Short Cut' buttons are at the bottom left.</p>
2	Select the signal status.	<p>The status changes to " <input type="text" value="SIM"/> " or " <input type="checkbox"/> " each time the [SELECT] key is pressed.</p>  <p>The screenshot is similar to the first one, but signal #30010 now has 'SIM' entered in its status box. Signal #30017 still has a selected radio button.</p> <p><input type="text" value="SIM"/> : status of forced signal output <input type="checkbox"/> : standard status</p>

13 How to Monitor Signals

13.2 I/O Status Window

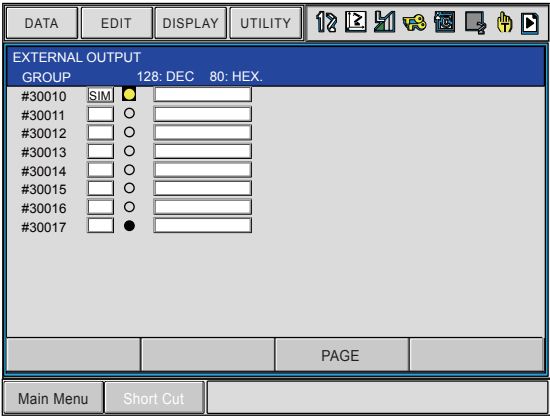
	Operation	Explanation
3	Select the signal status.	<p>Move the cursor to the status ("●" or "○") specified as "SIM". Only the signal status specified as "SIM" changes each time the [INTERLOCK] +[SELECT] keys are pressed.</p> 



CAUTION

- Changing the status of external output signal by specifying "SIM" also changes the signals output to the actual external devices.
Before forcibly changing the signal status, verify the destination device of each signal, and check on how the change effects on the device.

Failure to observe this caution may result in injury or damage to equipment.



- Perform the following check operation for safety when operating the manipulator with "SIM" (forced signal output) is remained selected for the universal input signal.

1. If any of the universal input signal is set to "SIM", the confirmation dialog box appears when starting a job.

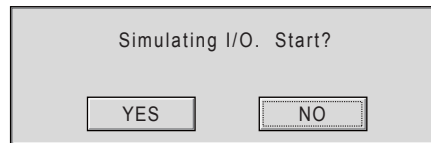

Select "YES" when executing the job in the status of the forced signal output. The job starts running by performing the start operation again after the dialog box disappears.

Select "NO" when not executing the job in the status of the forced signal output. Cancel the "SIM" status after the dialog box disappears.

2. If any of the external output signal is set to "SIM", the confirmation dialog box appears when operating the manipulator (JOG, FWD/BWD operations) with the programming pendant.

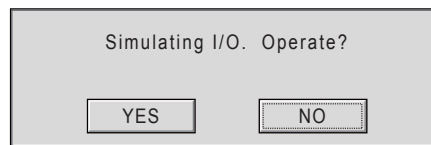

Select "YES" when operating the manipulator in the status of the forced signal output.

The manipulator can be operated after the dialog box disappears.

Select "NO" when not operating the manipulator in the status of the forced signal output.

Cancel the "SIM" status after the dialog box disappears.

- Concurrent I/O program reflects the actual signal status regardless of the "SIM" setting status of the external output signal.

For example, even if building a circuit in the ladder program as follows, #30011 is not ON when "SIM" is selected and the signal status set to "ON" ("●") for #30010. (The ON-OFF status of normal signal is referred in the ladder program.)

```
STR #30010
OUT #30011
```

13 How to Monitor Signals

13.2 I/O Status Window

13.2.4 Changing Signal Status from the External Input Window

The status of the external input signals can be changed by performing the following procedure.

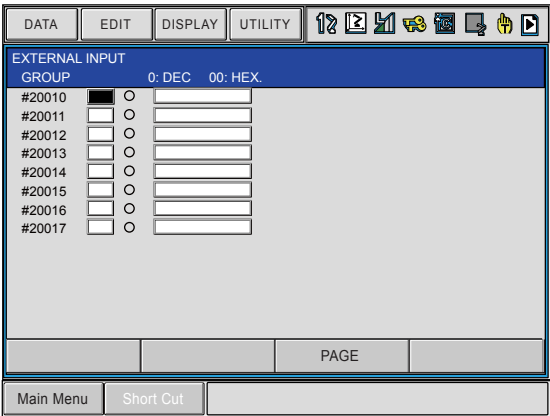
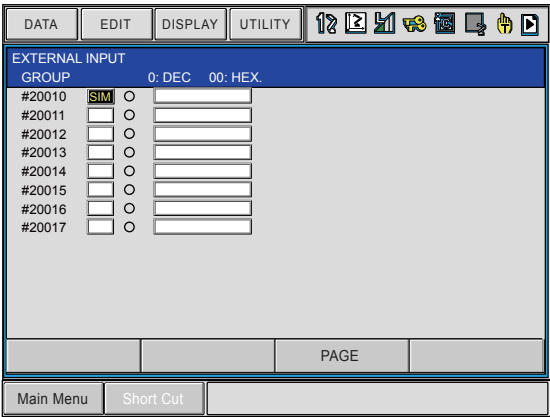
	Operation	Explanation
1	Select the signal desired to be changed.	<p>Move the cursor to the small box " <input type="checkbox"/> " on the row of the signal to be changed in the External Input window.</p> 
2	Select the signal status.	<p>The status changes to " <input type="checkbox"/> SIM " or " <input type="checkbox"/> " each time the [SELECT] key is pressed.</p>  <p><input type="checkbox"/> SIM : status of forced signal output <input type="checkbox"/> : standard status</p>

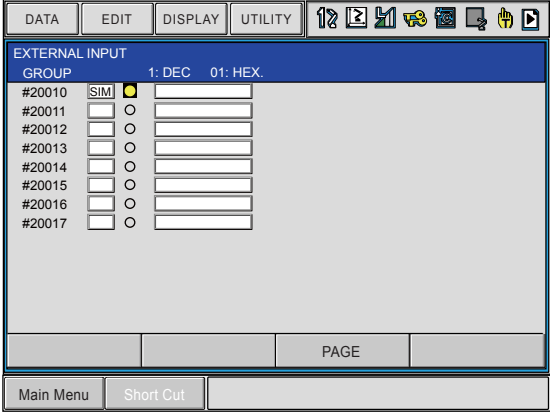
	Operation	Explanation
3	Select the signal status.	<p>Move the cursor to the status ("●" or "○") specified as "SIM". Only the signal status specified as "SIM" changes each time the [INTERLOCK] +[SELECT] keys are pressed.</p> 



CAUTION

- When changing the status of external input signal by specifying "SIM", parameters can be set as follows:

S2C296=0 (Default)

Changes only the internal status (signal indication) if the output status of signals to the external device has been changed with the concurrent I/O program due to the change of external input signals.

The output status for external device remains the same condition when the "SIM" mode was selected.

Restores the original status by cancelling all the "SIM" mode.

S2C296=1

Changes the signals output to the actual external devices if the output status of signals to the external device has been changed with the concurrent I/O program due to the change of external input signals.

Before forcibly changing the signal status, verify the destination device of each signal, and check on how the change effects on the device.

Failure to observe this caution may result in injury or damage to equipment.

13 How to Monitor Signals

13.2 I/O Status Window

NOTE

- Perform the following check operation for safety when operating the manipulator with "SIM" (forced signal output) is remained selected for the universal input signal.

1. If any of the universal input signal is set to "SIM", the confirmation dialog box appears when starting a job.

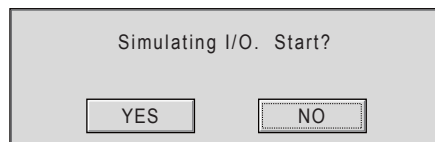

Select "YES" when executing the job in the status of the forced signal output. The job starts running by performing the start operation again after the dialog box disappears.

Select "NO" when not executing the job in the status of the forced signal output. Cancel the "SIM" status after the dialog box disappears.

2. If any of the external output signal is set to "SIM", the confirmation dialog box appears when operating the manipulator (JOG, FWD/BWD operations) with the programming pendant.

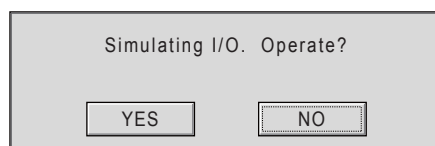

Select "YES" when operating the manipulator in the status of the forced signal output. The manipulator can be operated after the dialog box disappears.



The manipulator can be operated after the dialog box disappears.

Select "NO" when not operating the manipulator in the status of the forced signal output.

Cancel the "SIM" status after the dialog box disappears.

13.3 Pseudo Input Signal Window

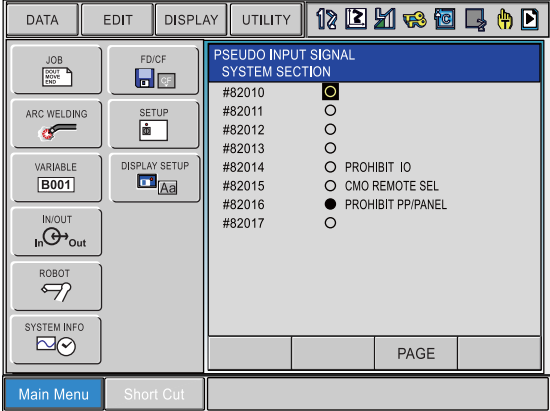
The status and name of the pseudo input signals can be checked with this window.

	Operation	Explanation
1	Select {IN/OUT} under the main menu	
2	Select {PSEUDO INPUT SIG}	<p>The pseudo input signal window appears..</p> 
3	Press the page key  .	<p>The system section (#82010-#82087) and the user section (#82090-#82127) are changed alternately with the page key  .</p>

13 How to Monitor Signals

13.3 Pseudo Input Signal Window

The signals can be turned ON/OFF in the pseudo input signal window in the management mode.

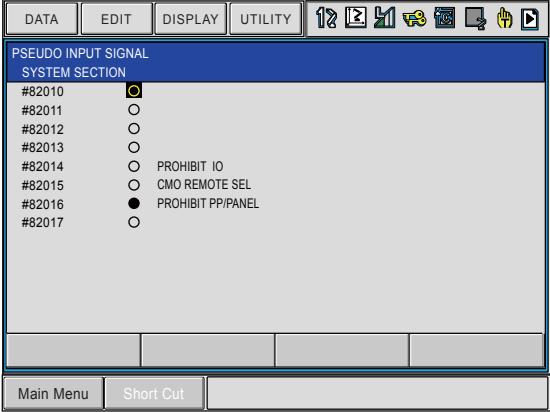
	Operation	Explanation
1	Select the signal to be changed.	<p>Move the cursor to the signal status to be changed. The signal status is indicated as either “○” or “●”.</p> 
2	Select the signal status.	<p>The signal status changes each time the [INTERLOCK] +[SELECT] keys are pressed. (●: ON; ○: OFF)</p>

Signal name can be registered in the user section of the pseudo input signal window in the management mode.

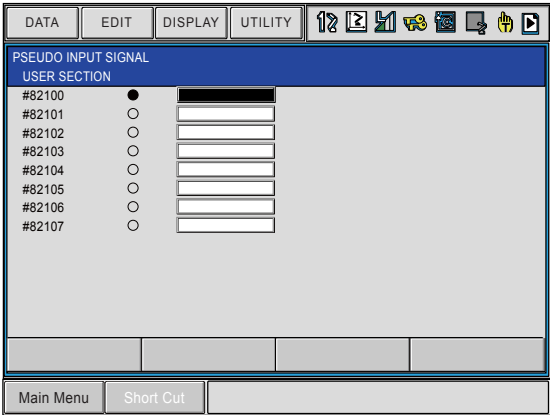
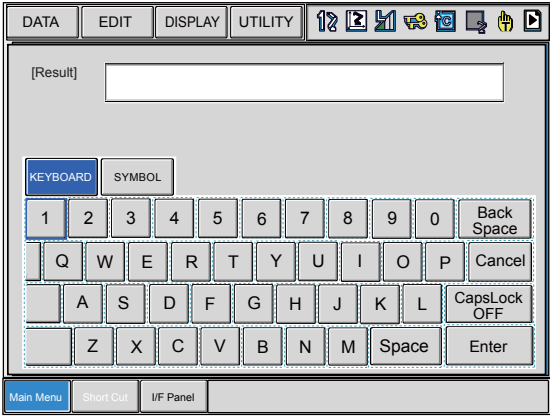
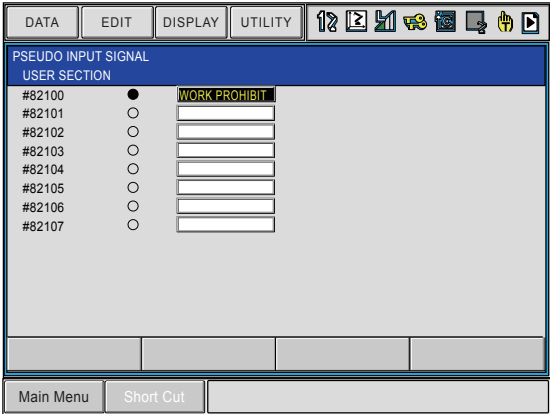
	Operation	Explanation
1	Select the signal name to be changed.	<p>Move the cursor to the desired signal name to be registered, and press [SELECT] to enable character entry. Enter up to 8 one-byte characters.</p>  
2	Input the signal name.	
3	Press [ENTER].	<p>Input the signal name and press [ENTER]. The name is registered.</p> 

13 How to Monitor Signals
 13.4 Register Window

13.4 Register Window

The register can be checked in the register window.

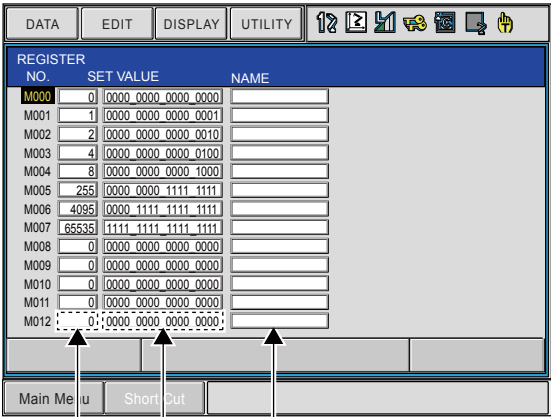
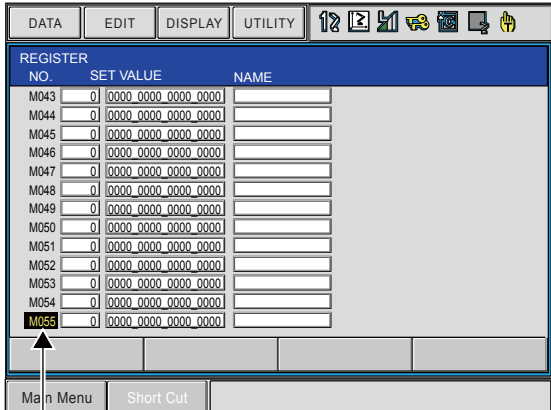
	Operation	Explanation
1	Select {IN/OUT} under the main menu.	
2	Select {REGISTER}.	<p>The register window appears.</p>  <p style="text-align: center;"> Decimal Binary Signal name (Up to 16 one-byte/8 two-byte characters) </p>
3	Move the cursor to the desired register number.	<p>When the desired register number is not displayed, move the cursor in the following manner: move the cursor to "NO." and press [SELECT]; enter the desired register number using the numeric keys, then press [ENTER]. The cursor moves to the specified register number.</p>  <p style="text-align: center;">The cursor moves to the desired register number.</p>

A register can be set in the management mode.

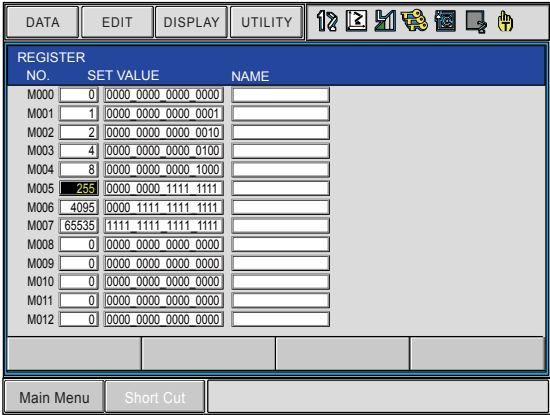
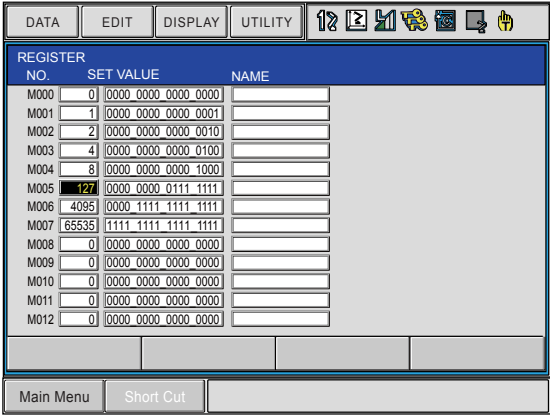
	Operation	Explanation																
1	Select the register data to be set.	<p>Move the cursor to the data (decimal or binary) of the register number to be set in the register window, and press [SELECT].</p> <ul style="list-style-type: none"> -When the decimal data is selected, enter a decimal value. -When the binary data is selected, enter a binary value. 																
2	Enter a desired numerical value.	<p>When a decimal value is selected, enter decimal value data using the numeric keys.</p> <p>M005 <input type="text" value="127"/> ← Enter data with the numeric keys</p> <p>When a binary value is selected, move the cursor to a binary data to be set in the input line, and press [SELECT]. Each time [SELECT] is pressed, "0" and "1" are displayed alternately. Also, "0" and "1" can be entered using the NUMBERKEYS.</p> <p>M005 <input type="text" value="255"/> <table border="1" data-bbox="927 1240 1351 1339"> <tr> <td>0</td><td>0</td><td>0</td><td>0</td><td>0</td><td>0</td><td>0</td><td>0</td> </tr> <tr> <td>0</td><td>1</td><td>1</td><td>1</td><td>1</td><td>1</td><td>1</td><td>1</td> </tr> </table></p> <p>↑ Change values (1 ↔ 0) with the SELECT key</p>	0	0	0	0	0	0	0	0	0	1	1	1	1	1	1	1
0	0	0	0	0	0	0	0											
0	1	1	1	1	1	1	1											
3	Press [ENTER].	<p>The entered numerical value is set at the cursor position.</p> 																

13 How to Monitor Signals

13.4 Register Window

NOTE

The registers used as current value of TMR/CNT instruction in the ladder program cannot be set.

<Example of Ladder Program>

STR #70010

TMR M010, M011 <-- M010 (current value) cannot be set in the register window;
OUT #70011 M011 (current value) can be set in the register window.

STR #70020

STR #70021

CNT #M020, M021 <-- M020 (current value) cannot be set in the register window;
OUT #70021 M021 (current value) can be set in the register window.

:

The signal name can be registered by performing the following procedure.

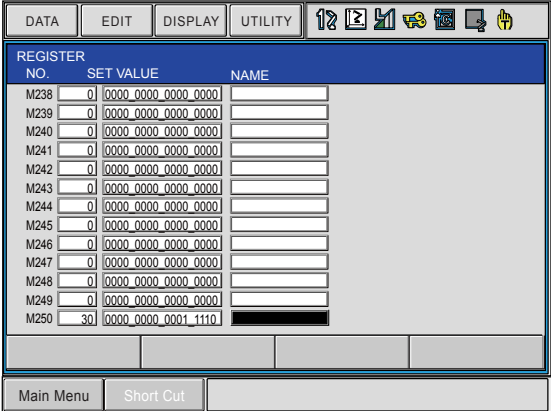
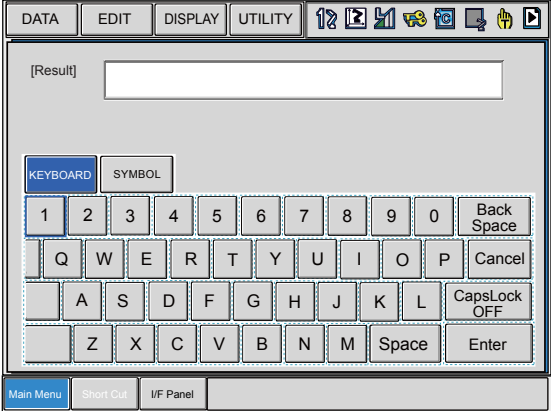
	Operation	Explanation
1	Select the signal name to be registered.	<p>Move the cursor to the desired signal name to be registered, and press [SELECT] to enable character entry. Enter up to 16 one-byte (or 8 two-byte) characters.</p>  
2	Enter the signal name.	

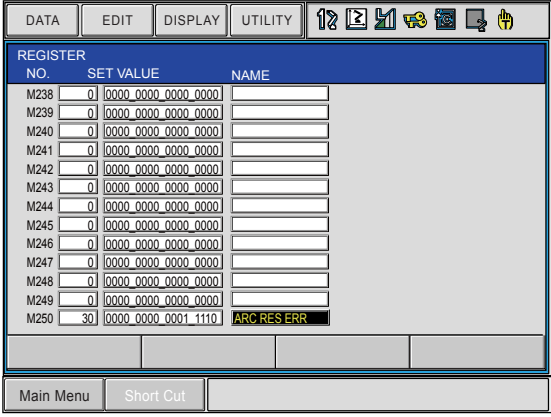
	Operation	Explanation																																										
3	Press [ENTER].	<p>The name is registered.</p>  <p>The screenshot shows a software interface window titled 'REGISTER'. At the top, there are menu tabs: 'DATA', 'EDIT', 'DISPLAY', and 'UTILITY'. Below these are several icons. The main area contains a table with three columns: 'NO.', 'SET VALUE', and 'NAME'. The table lists registers from M238 to M250. Register M250 is highlighted in yellow and has the name 'ARC RES ERR' entered in the 'NAME' column. At the bottom of the window, there are buttons for 'Main Menu' and 'Short Cut'.</p> <table border="1" data-bbox="790 358 1316 649"> <thead> <tr> <th>NO.</th> <th>SET VALUE</th> <th>NAME</th> </tr> </thead> <tbody> <tr><td>M238</td><td>0</td><td>0000_0000_0000_0000</td></tr> <tr><td>M239</td><td>0</td><td>0000_0000_0000_0000</td></tr> <tr><td>M240</td><td>0</td><td>0000_0000_0000_0000</td></tr> <tr><td>M241</td><td>0</td><td>0000_0000_0000_0000</td></tr> <tr><td>M242</td><td>0</td><td>0000_0000_0000_0000</td></tr> <tr><td>M243</td><td>0</td><td>0000_0000_0000_0000</td></tr> <tr><td>M244</td><td>0</td><td>0000_0000_0000_0000</td></tr> <tr><td>M245</td><td>0</td><td>0000_0000_0000_0000</td></tr> <tr><td>M246</td><td>0</td><td>0000_0000_0000_0000</td></tr> <tr><td>M247</td><td>0</td><td>0000_0000_0000_0000</td></tr> <tr><td>M248</td><td>0</td><td>0000_0000_0000_0000</td></tr> <tr><td>M249</td><td>0</td><td>0000_0000_0000_0000</td></tr> <tr><td>M250</td><td>30</td><td>0000_0000_0001_1110 ARC RES ERR</td></tr> </tbody> </table>	NO.	SET VALUE	NAME	M238	0	0000_0000_0000_0000	M239	0	0000_0000_0000_0000	M240	0	0000_0000_0000_0000	M241	0	0000_0000_0000_0000	M242	0	0000_0000_0000_0000	M243	0	0000_0000_0000_0000	M244	0	0000_0000_0000_0000	M245	0	0000_0000_0000_0000	M246	0	0000_0000_0000_0000	M247	0	0000_0000_0000_0000	M248	0	0000_0000_0000_0000	M249	0	0000_0000_0000_0000	M250	30	0000_0000_0001_1110 ARC RES ERR
NO.	SET VALUE	NAME																																										
M238	0	0000_0000_0000_0000																																										
M239	0	0000_0000_0000_0000																																										
M240	0	0000_0000_0000_0000																																										
M241	0	0000_0000_0000_0000																																										
M242	0	0000_0000_0000_0000																																										
M243	0	0000_0000_0000_0000																																										
M244	0	0000_0000_0000_0000																																										
M245	0	0000_0000_0000_0000																																										
M246	0	0000_0000_0000_0000																																										
M247	0	0000_0000_0000_0000																																										
M248	0	0000_0000_0000_0000																																										
M249	0	0000_0000_0000_0000																																										
M250	30	0000_0000_0001_1110 ARC RES ERR																																										

13.5 Servo Power Status Window

The status of "ON_EN" signals connected to each power ON unit and servo power supply of each control group can be checked in the Servo Power Status window.

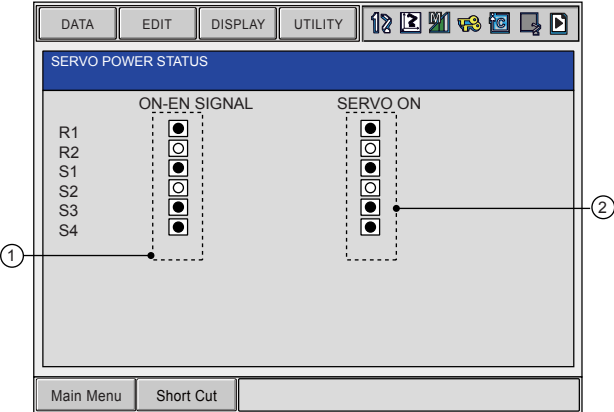
	Operation	Explanation
1	Select {IN/OUT} under the main menu.	
2	Select {SERVO POWER STATUS}.	<p>The servo power status window appears.</p>  <p>① ON_EN SIGNAL Displays the status of Power On unit "ON_EN" signal that each control group is connected.</p> <p>○: Open (OFF) status The servo power supply is shut down.</p> <p>●: Close (ON) status When the servo ON lamp is lit, the servo power supply is turned ON.</p> <p>② SERVO ON Displays the status (specific output 50180 to 50197) of servo power supply of each control group.</p> <p>○: Servo power supply shut down</p> <p>●: Servo power ON completed</p>

13.6 Analog Output Window

The current settings can be checked in the Analog Output window.

	Terminal	AOUT1	AOUT2	AOUT3	AOUT4	
①	•					
②	•	OUTPUT (V):	-14.00	-14.00	-10.00	-14.00
③	•	BASIC (V) :	0.00	0.00	0.00	0.00
④	•	TRAIT :	SP RAT	SP RAT	SP RAT	SP RAT
⑤	•	OFFSET (V):	0.00	0.00	0.00	0.00
⑥	•	BASIC SPD :	1200.0	1200.0	1200.0	1200.0
⑦	•	ROBOT :	R1	R2	R3	R4

① TERMINAL

The general-purpose analog output ports are displayed.

② OUTPUT (V)

The current output voltage is displayed.

③ BASIC (V)

The basic voltage used for executing the analog output corresponding to speed is displayed.
The value can be overwritten by setting a new value using ARATION instruction.

④ TRAIT

The current output characteristic of output port is displayed.
SP RAT: Executing analog output corresponding to speed.
STATIC: The output is fixed.

⑤ OFFSET (V)

The offset voltage used for executing the analog output corresponding to speed is displayed.
The value can be overwritten by setting a new value using ARATION instruction.

⑥ BASIC SPD

The basic speed used for executing the analog output corresponding to speed is displayed.
The value can be overwritten by setting a new value using ARATION instruction.

⑦ ROBOT



The manipulator No. for the analog output corresponding to speed is displayed.

	Operation	Explanation
1	Select {IN/OUT} under the main menu.	
2	Select {ANALOG OUTPUT}.	The analog output window appears. The window for the output terminal AOUT1 to 4, AOUT 5 to 8, and AOUT 9 to 12 can be switched by pressing the page key  .

13.7 I/O Messages and I/O Alarms

13.7.1 Registering the User Section

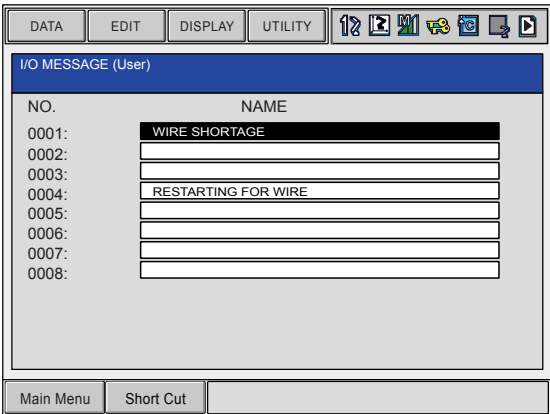
User section I/O alarms and I/O messages can be displayed or registered in the management mode by the following procedures:

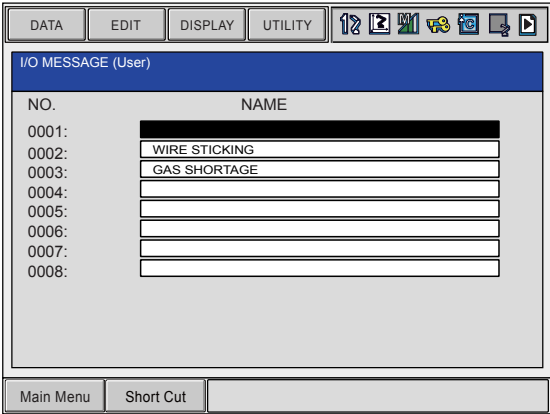
	Operation	Explanation
1	Select {IN/OUT} under the main menu.	
2	Select {IO ALARM} or {IO MESSAGE}.	<p>The user section or the system section under the selected sub-menu (I/O Alarm or I/O Message) is displayed.</p> 
3	Press the page key  .	<p>TO change between the user section and the system section, use the page key .</p> 

User section I/O alarms and I/O messages can be displayed or registered by the following procedures. However, the system I/O alarms and I/O messages cannot be edited.

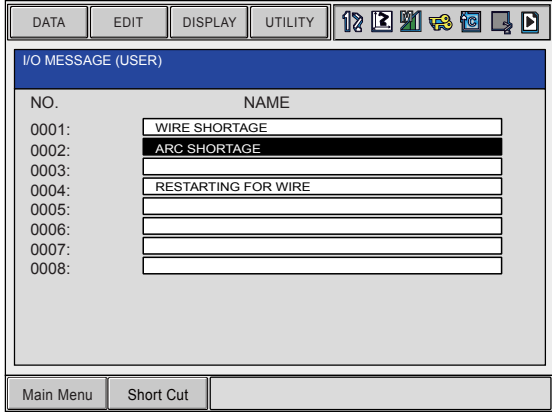
Operation	Explanation
<p>1 Select the name to be changed.</p>	<p>Move the cursor to the name to be changed in either the I/O Alarm (User Section) window or the I/O Message (User Section) window, and press [SELECT]. The character input status window appears. Enter up to 32 one-byte characters for the Alarm and Message windows respectively. Up to 8 messages can be registered for each window.</p> 
<p>2 Input the I/O Alarm Name or the I/O Message Name.</p>	
<p>3 Press [ENTER].</p>	<p>Enter the name in the input line, and press [ENTER]. The name is displayed.</p> 

13 How to Monitor Signals

13.8 Ladder Program Window

13.8 Ladder Program Window

This window allows operators to check the ON-OFF status of signals and register values included in the ladder program.

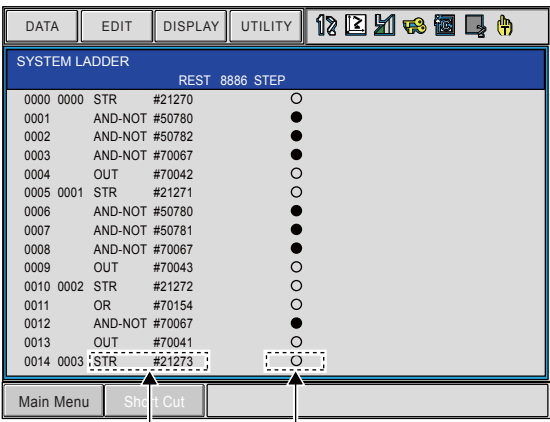
	Operation	Explanation
1		Set the security mode to the management mode. (The {LADDER PROGRAM} menu is not displayed in the operation/edit mode.)
2	Select {IN/OUT} from the main menu.	
3	Select {LADDER PROGRAM}.	The ladder program window appears.  <p>The screenshot shows a window titled 'SYSTEM LADDER' with a menu bar (DATA, EDIT, DISPLAY, UTILITY) and a toolbar. The main area displays a list of steps with columns for address, instruction, and monitor status. The monitor status column contains circles, some filled (ON) and some empty (OFF). Below the list are buttons for 'Main Menu', 'Shot Cut', and 'Monitor display'. Arrows point from the 'Shot Cut' and 'Monitor display' buttons to the corresponding columns in the list.</p>





- The programming pendant will not display the monitor indication while the ladder program is edited. The monitor indication restarts if compiling the edited ladder program succeeds and ends with a normal termination.
- Setting of whether to display the monitor indication in the ladder program window can be specified with the following parameters.
 - S2C304=1 (Default)
Enables monitor indication in the ladder program window.
 - S2C304=0
Disables monitor indication in the ladder program window.

The monitor indication may be displayed differently depending on the instruction types of ladder program.

	Instruction	Description
1	STR OR AND OUT PLS PLF	<p>"●" signifies the ON status of operand relay number signal. "○" signifies the OFF status of operand relay number signal.</p> <p><Example> STR #20010 ● : #20010=ON-status</p>
2	STR-NOT OR-NOT AND-NOT	<p>"●" signifies the OFF status of operand relay number signal. "○" signifies the ON status of operand relay number signal.</p> <p><Example> STR-NOT #20010 ● : #20010=OFF-status</p>
3	GSTR GOUT	<p>Indicates the 8 bit data value from the operand relay number in the decimal/hexadecimal number. (The value in parentheses indicates the hexadecimal number.)</p> <p><Example> GOUT #00010 128 (80H)</p> <div style="margin-left: 200px;"> </div> <p>In this case, #00010 to #00016=OFF-status, and #00017=ON-status.</p>
4	CNT TMR	<p>Indicates the register value (16 bits) of the current value operand (the 1st operand) in the decimal/hexadecimal number. (The value in parentheses indicates the hexadecimal number.)</p> <p><Example> TMR M010, M011 10 (000aH)</p> <div style="margin-left: 200px;"> </div> <p>In this case, setting is M010=10.</p>
5	ADD SUB DIV MOD	<p>Indicates the register value (16 bits) of the calculation result operand (the 3rd operand) in the decimal/hexadecimal number. (The value in parentheses indicates the hexadecimal number.)</p> <p><Example> ADD M020, M021, M022 100 (0064H)</p> <div style="margin-left: 200px;"> </div> <p>In this case, setting is M022=100.</p>
6	MUL	<p>Indicates the register value (16 bits) of the calculation result operand (the 3rd operand) in the decimal/hexadecimal number. (The value in parentheses indicates the hexadecimal number.) However, if the calculation result exceeds 16 bits, the register value will be indicated in 32-bit value in the decimal/hexadecimal number.</p> <p><Example> MUL M030, M031, M032 65536 (00010000H)</p> <div style="margin-left: 200px;"> </div> <p>In this case, setting is M032=65536.</p>

13 How to Monitor Signals

13.8 Ladder Program Window

	Instruction	Description
7	WAND WOR WXOR SHL SHR ROL ROR	<p>Indicates the value of the register/word-type relay/byte type relay of the calculation result operand (the 3rd operand) in the decimal/hexadecimal number. (The value in parentheses indicates the hexadecimal number.)</p> <p>Register, word-type relay: 16 bits Byte-type relay: 8 bits</p> <p><Example> SHL M040, 4, M041 4096 (1000H)</p>  <p>In this case, setting is M041=4096.</p>
8	WNOT MOV BIN BCD	<p>Indicates the value of the register/word-type relay/byte type relay of the calculation result operand (the 2nd operand) in the decimal/hexadecimal number. (The value in parentheses indicates the hexadecimal number.)</p> <p>Register, word-type relay: 16 bits Byte-type relay: 8 bits</p> <p><Example> MOV 255, #70010 255 (ffH)</p>  <p>In this case, #70010 to #70017=ON-status.</p>
9	AND-STR OR-STR END (PART) (NOP)	<p>The monitor indication will not be displayed.</p>

14 Editing Ladder Programs

14.1 Flow of Data by Ladder Programs

Flow of data in editing, storage, and execution areas by operation of ladder program is shown below.

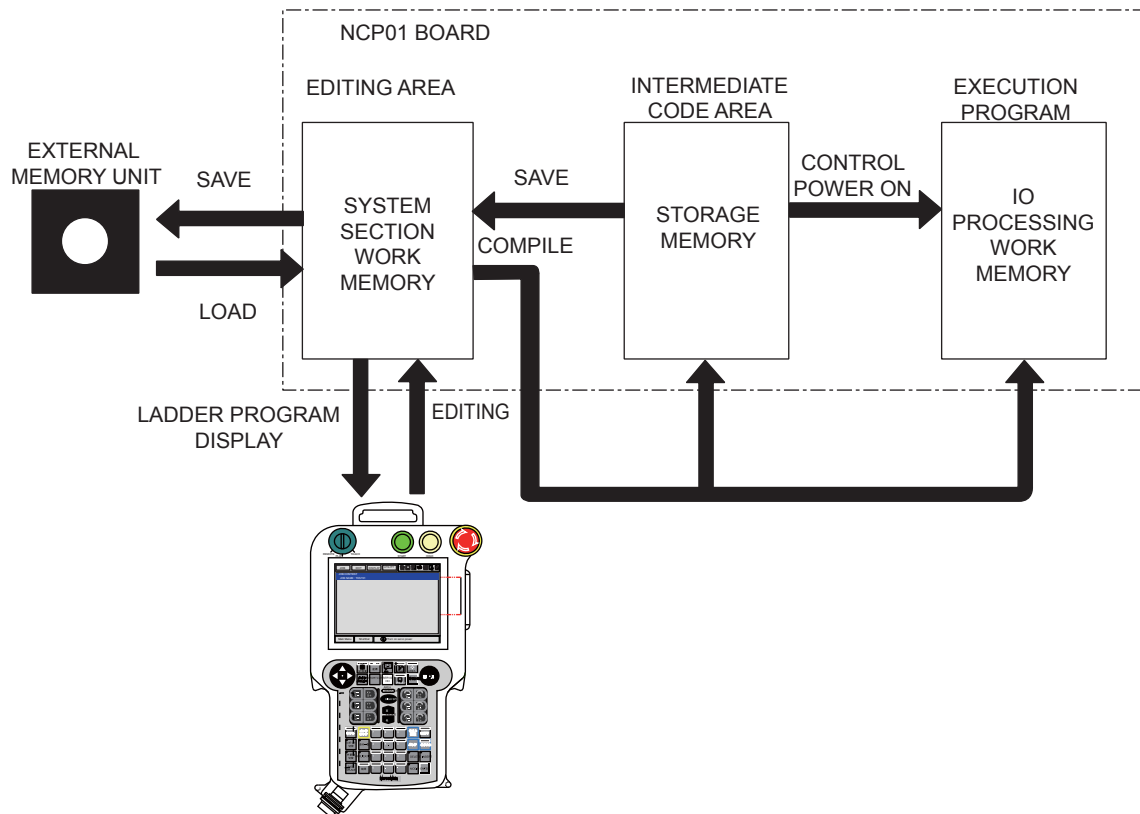

NOTE

- Only the user ladder program can be edited. The system ladder program cannot be edited.
- When the system ladder program is changed, the ladder program from the external memory unit cannot be loaded.
- If control power is shut down while the ladder program is being edited, the edited ladder program is lost. The intact program remains in the execution area.
- During editing of ladder programs, "EDITING" is displayed on the upper right of the user section window. This indication appears only when the program in the editing area and that in the execution area do not match. Nothing is displayed after compilation or cancellation of editing when the programs in the two areas match.

14 Editing Ladder Programs

14.2 Editing by Mnemonic and Ladder Editor Program

14.2 Editing by Mnemonic and Ladder Editor Program

The editing operations for ladder programs are two ways as follows.

1. Editing by Mnemonic Codes

Ladder programs can be edited in mnemonic codes as shown below.

0000	0000	STR	#20010
0001		OUT	#70010
0002	0001	STR	#20012
0003		OUT	#40030
0004	0002	STR	#20013
0005		OUT	#40014
0006	0003	STR	#20013
0007		OUT	#70030
0008	0004	STR	#20021
0009		OUT	#70031

2. Ladder Editor Program (Optional Function)

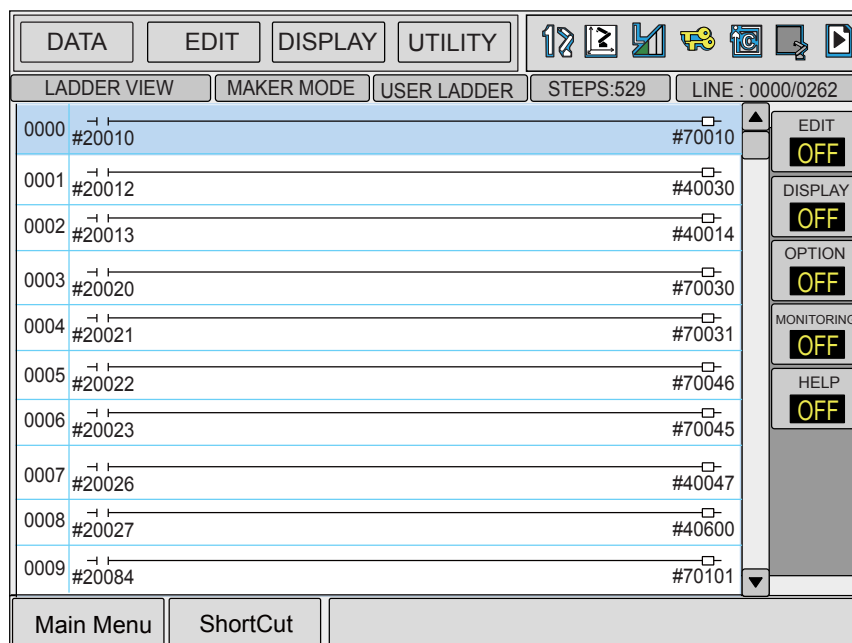

Ladder programs can be edited with the image of ladders as shown in the window below.



14.3 Mnemonic Editing Window

14.3.1 Basic Operation

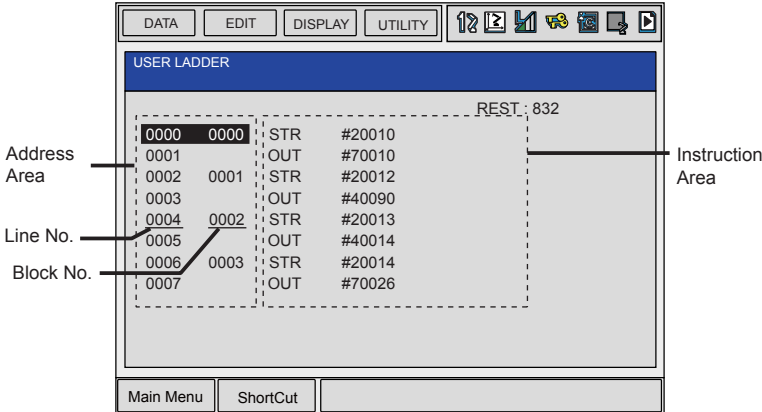
Ladder program is protected so that it cannot be easily changed. The following operations are authorized only to those who can input a user ID No. (security: management mode).

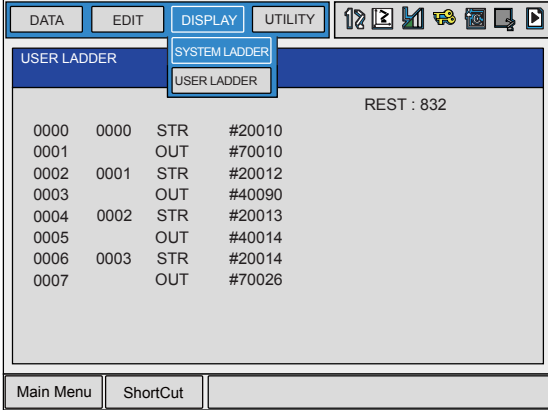
	Operation	Explanation
1	Select {IN/OUT} under the main menu	
2	Select {LADDER PROGRAM}	<p>The C.I/O user section is displayed.</p>  <p>To confirm the system ladder program, press the PAGE KEY , or select [DISP]→[SYSTEM LADDER] under the menu.</p> 
3	Edit Operation	For each editing operations, see section 14.3.2 "Editing Operation" on the following pages. The system ladder program cannot be edited.
4	Select {DATA} under the menu	
5	Select {COMPILE}	

14 Editing Ladder Programs

14.3 Mnemonic Editing Window

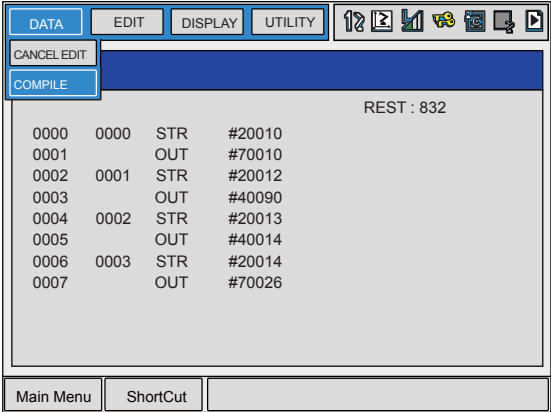
	Operation	Explanation
6	Select "YES"	<p>The edited ladder program is checked for syntax error. If no error is found, the new program is written into the execution area to run. If any error is found in the edited ladder program, the erroneous step is identified. In this case, the program stored in the execution area remains unchanged.</p>  <p>The screenshot shows a software window titled 'Mnemonic Editing Window'. At the top, there are menu tabs: 'DATA', 'EDIT', 'DISPLAY', and 'UTILITY'. Below these are several icons. A 'COMPILE' button is highlighted in blue. Below the button, the text 'REST : 832' is displayed. The main area contains a list of ladder program steps:</p> <pre> 0000 0000 STR #20010 0001 OUT #70010 0002 0001 STR #20012 0003 OUT #40090 0004 0002 STR #20013 0005 OUT #40014 0006 0003 STR #20014 0007 OUT #70026 </pre> <p>At the bottom of the window, there are buttons for 'Main Menu' and 'ShortCut'.</p>



The cursor moves up/down by line each time the up/down cursor key is pressed. Pressing [SHIFT] + up/down cursor key moves the cursor up/down by five lines at a time.

14.3.2 Editing Operation

The editing operation is divided into the instruction registration operation (adding, changing, and deleting) and the operand edit operation.

■ Inserting Instruction

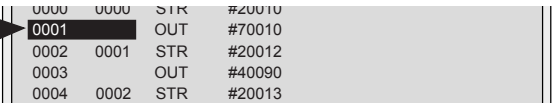
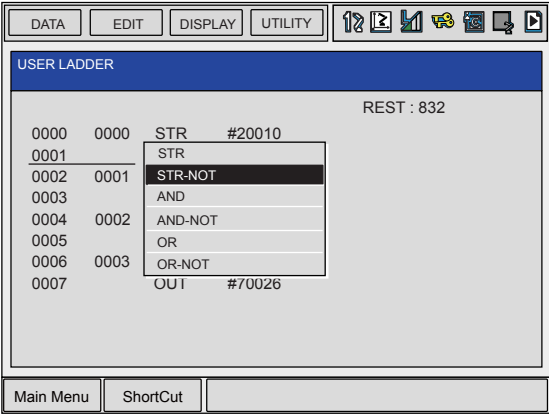
	Operation	Explanation
1	Move the cursor to the address area	<p>The line before the instruction to be added</p>  <pre> 0000 0000 STR #20010 0001 0000 OUT #70010 0002 0001 STR #20012 0003 0002 OUT #40090 0004 0002 STR #20013 </pre>
2	Select the line before the line you wish to add	<p>The instruction list dialog box is displayed. Move the cursor to the instruction list dialog, and the cursor in the address area becomes underlined.</p> 

14 Editing Ladder Programs

14.3 Mnemonic Editing Window

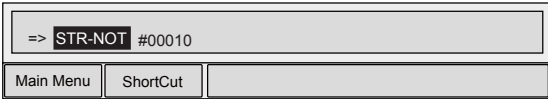
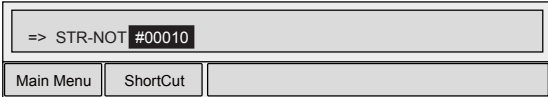
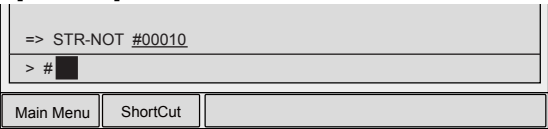
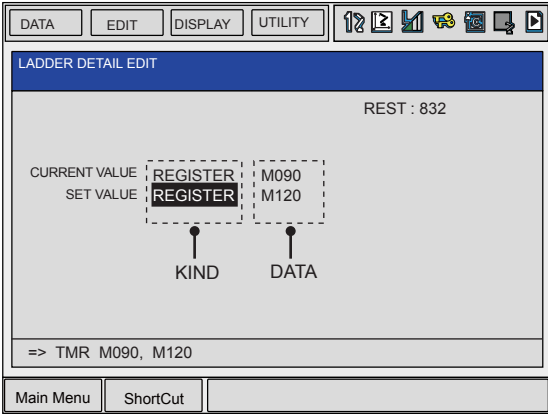
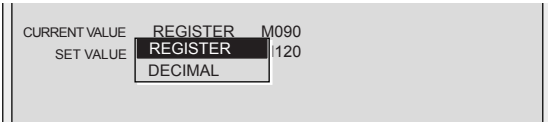
	Operation	Explanation
3	Select the instruction to be inserted	<p>Move the cursor to the input buffer line instruction.</p>  <p>When there are more than two kinds of operand instructions, move the cursor to the instruction and press [SELECT]. A detailed screen is displayed. When changing numeric data, move the cursor to the data to be corrected and press the [SHIFT] + [CURSOR KEY] simultaneously. The numeric data then increases and decreases.</p>  <p>To directly input the numeric value, press [SELECT]. The input line is displayed, then input the data using the [NUMBER KEY] and press [ENTER].</p>  <ul style="list-style-type: none"> • Instructions with Two or More Kinds of Operands The input line is displayed. Input the data using the [NUMBER KEY] and press [ENTER]. • Instructions with Two or More Kinds of Operands When changing the type of operand, move the cursor to the operand and press [SELECT] to select the operand type.   <p>Move the cursor to the operand data and press [SELECT] to change the operand.</p> <p>If the type of operand and data are changed, press [ENTER]. The ladder detail edit window closes, and the ladder program window is displayed.</p>
4	Press [ADD]	

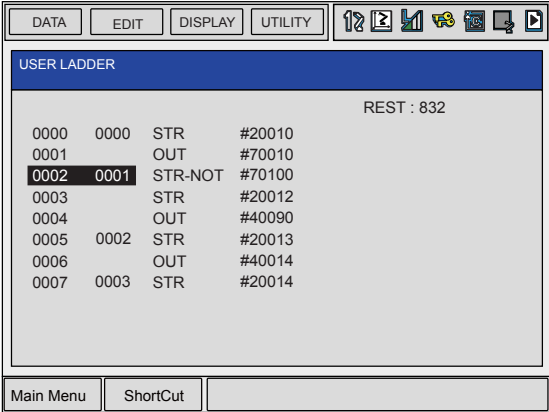
	Operation	Explanation
5	Press [ENTER]	<p>The instruction indicated in the input buffer line is added. When adding an instruction just before the END instruction, do not press [ADD]. If there is a change, press [SELECT] in the instruction area, and repeat the numeric input operation.</p>  <p>The screenshot shows a window titled 'USER LADDER' with a menu bar (DATA, EDIT, DISPLAY, UTILITY) and a toolbar. The main area displays a list of instructions:</p> <pre> 0000 0000 STR #20010 0001 OUT #70010 0002 0001 STR-NOT #70100 0003 STR #20012 0004 OUT #40090 0005 0002 STR #20013 0006 OUT #40014 0007 0003 STR #20014 </pre> <p>The instruction '0002 0001 STR-NOT #70100' is highlighted. At the top right of the window, it says 'REST : 832'. At the bottom, there are buttons for 'Main Menu' and 'ShortCut'.</p>

14 Editing Ladder Programs

14.3 Mnemonic Editing Window

■ Changing Instructions

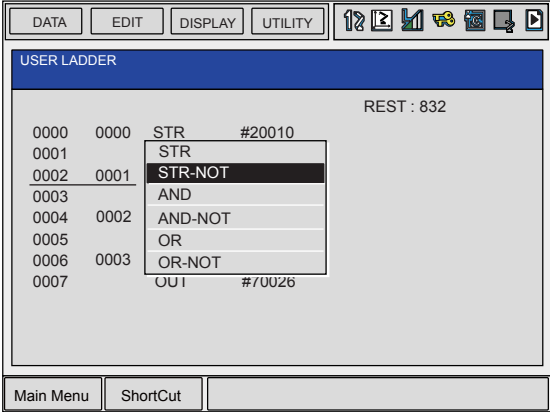
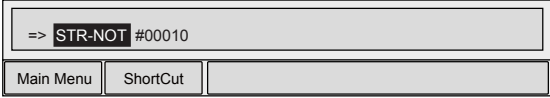
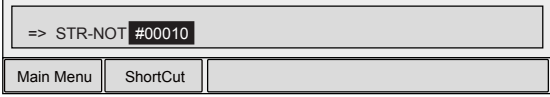
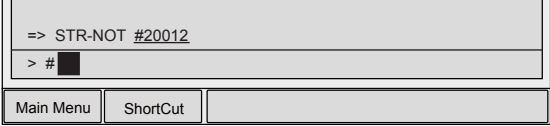
	Operation	Explanation
1	Move the cursor to the address area	<p>The instruction line to be changed</p> 
2	Select the line to be changed	<p>The instruction select dialog box is displayed. The cursor moves to the instruction list, and the cursor in the address area is underlined.</p> 
3	Select the instruction to be changed	<p>Move the cursor to the input buffer line instruction.</p>  <p>When there are more than two kinds of operand instructions, move the cursor to the instruction and press [SELECT]. A detailed screen is displayed. When changing numeric data, move the cursor to the data to be corrected and press the [SHIFT] + CURSOR simultaneously. The numeric data then increases and decreases.</p>  <p>To directly input the numeric value, press [SELECT]. The input line appears. Input the data using the NUMBER KEY and press [ENTER].</p> 
4	Press [MODIFY]	

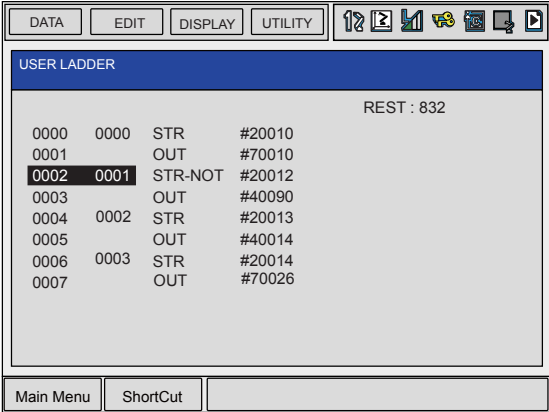
	Operation	Explanation																																				
5	Press [ENTER]	The instruction displayed in the input buffer line is changed.  <p>The screenshot shows a software window titled 'USER LADDER'. At the top, there are four menu buttons: 'DATA', 'EDIT', 'DISPLAY', and 'UTILITY'. To the right of these are several icons for navigation and editing. Below the menu bar, the text 'USER LADDER' is displayed in a blue header. Underneath, the text 'REST : 832' is shown. The main area contains a list of ladder logic instructions:</p> <table border="1"><thead><tr><th>Address</th><th>Input</th><th>Instruction</th><th>Output</th></tr></thead><tbody><tr><td>0000</td><td>0000</td><td>STR</td><td>#20010</td></tr><tr><td>0001</td><td></td><td>OUT</td><td>#70010</td></tr><tr><td>0002</td><td>0001</td><td>STR-NOT</td><td>#20012</td></tr><tr><td>0003</td><td></td><td>OUT</td><td>#40090</td></tr><tr><td>0004</td><td>0002</td><td>STR</td><td>#20013</td></tr><tr><td>0005</td><td></td><td>OUT</td><td>#40014</td></tr><tr><td>0006</td><td>0003</td><td>STR</td><td>#20014</td></tr><tr><td>0007</td><td></td><td>OUT</td><td>#70026</td></tr></tbody></table> <p>At the bottom of the window, there are two buttons: 'Main Menu' and 'ShortCut'.</p>	Address	Input	Instruction	Output	0000	0000	STR	#20010	0001		OUT	#70010	0002	0001	STR-NOT	#20012	0003		OUT	#40090	0004	0002	STR	#20013	0005		OUT	#40014	0006	0003	STR	#20014	0007		OUT	#70026
Address	Input	Instruction	Output																																			
0000	0000	STR	#20010																																			
0001		OUT	#70010																																			
0002	0001	STR-NOT	#20012																																			
0003		OUT	#40090																																			
0004	0002	STR	#20013																																			
0005		OUT	#40014																																			
0006	0003	STR	#20014																																			
0007		OUT	#70026																																			

14 Editing Ladder Programs

14.3 Mnemonic Editing Window

■ Delete Instructions

	Operation	Explanation
1	Move the cursor to the address area	
2	Move the cursor to the line to be deleted	
3	Press [DELETE]	
4	Press [ENTER]	<p>The cursor line instruction is deleted.</p> <pre> 0001 OUT #70010 0002 0001 STR #20012 0003 OUT #40090 0001 OUT #70010 0002 0001 STR #20012 0003 0002 OUT #40090 </pre>

■ Editing Operands

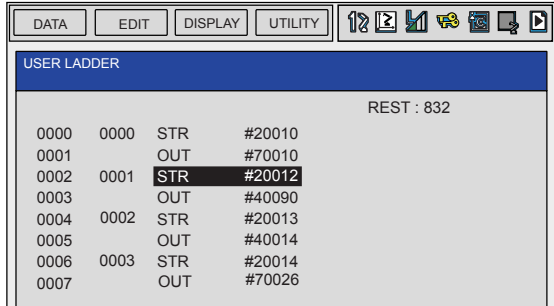
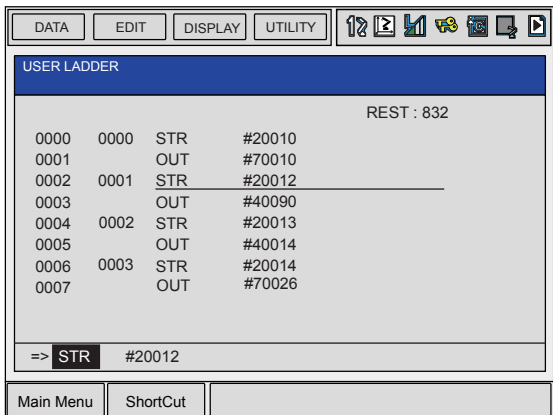
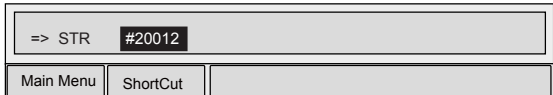
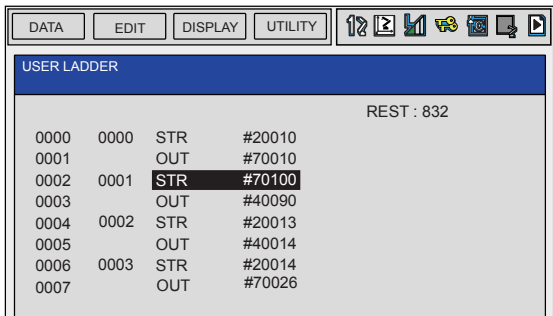
	Operation	Explanation
1	Move the cursor to the instruction area	
2	Select the line of the operand to be edited	<p>Move the cursor to the input buffer line instruction.</p> 
3	Edit Operation	<p>When there are more than two kinds of operand instructions, move the cursor in the instruction to and press [SELECT]. A detailed screen is displayed. When changing numeric data, move the cursor to the data to be corrected and press the [SHIFT] + CURSOR simultaneously. The numeric data then increases and decreases.</p>  <p>To directly input the numeric value, press [SELECT]. The input line appears. Input the data using the NUMBER KEY and press [ENTER].</p>
4	Press [ENTER]	<p>The cursor line operand is changed.</p> 

14 Editing Ladder Programs

14.3 Mnemonic Editing Window

■ Cancelling Editing

Use the following steps to cancel editing during the ladder program editing and to return to the preceding program.

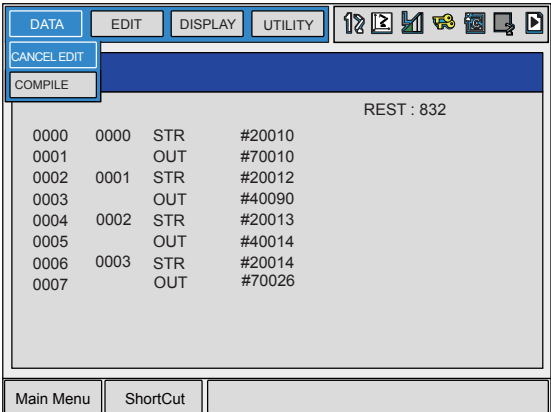
	Operation	Explanation
1	Select {DATA} under the menu	
2	Select {CANCEL EDIT}	
3	Select "YES"	 <p>The confirmation dialog box is displayed. When "YES" is selected, the program returns to the ladder program (executing program) before editing. When "NO" is selected, the cancel edit operation is cancelled, and the ladder program on the edit is displayed.</p>

14.3.3 Compile

Use the following steps to compile the ladder program after editing.

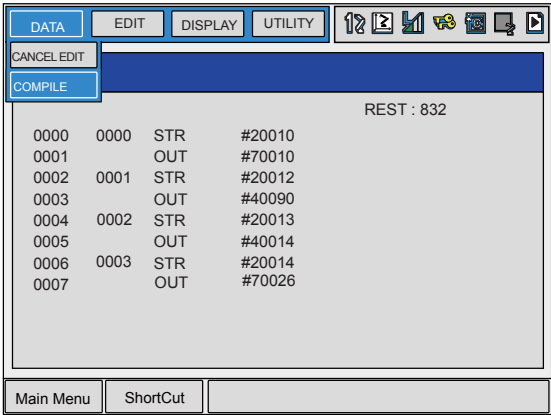
	Operation	Explanation
1	Select {DATA} under the menu	
2	Select {COMPILE}	<p>The ladder program starts compiling. The edited ladder program is checked for syntax error. If no error is found, the new program is written into the execution area to run. If any error is found in the edited ladder program, the erroneous step is identified. In this case, the program stored in the execution area remains unchanged.</p>  <p>The screenshot shows a software window titled 'Mnemonic Editing Window'. At the top, there are menu tabs: DATA, EDIT, DISPLAY, and UTILITY. Below these are several icons. A dropdown menu is open, showing 'CANCEL EDIT' and 'COMPILE' options. The main area of the window displays a list of instructions:</p> <pre> 0000 0000 STR #20010 0001 OUT #70010 0002 0001 STR #20012 0003 OUT #40090 0004 0002 STR #20013 0005 OUT #40014 0006 0003 STR #20014 0007 OUT #70026 </pre> <p>At the bottom of the window, there are buttons for 'Main Menu' and 'ShortCut', and a status bar on the right that reads 'REST : 832'.</p>



After completing the compilation, the current values of the TMR/CNT instructions in the register are restored to the set values.

14 Editing Ladder Programs

14.3 Mnemonic Editing Window

14.3.4 Search

The search function can be used for the edit and confirmation.

Search can be executed when the cursor is either in the address area, or the instruction area of the user ladder window or the system ladder window.

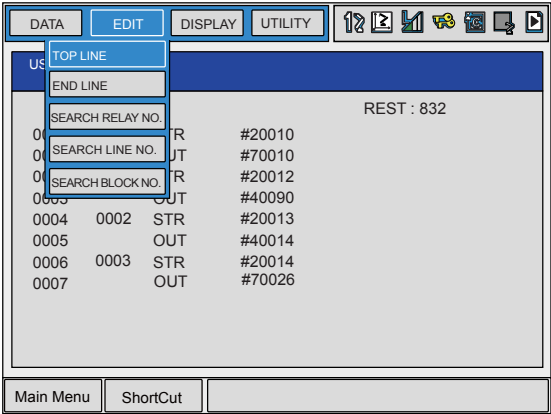
	Operation	Explanation
1	Select {IN/OUT} under the main menu	
2	Select {LADDER PROGRAM}	The user ladder window or the system ladder window appears. Press the PAGE KEY  to switch the window.
3	Select {EDIT} under the menu	The pull down menu appears. 
4	Select a desired search from the pull down menu	

The search is an operation to move the cursor to a specified line or relay No. line in the ladder window. This allows to find out a target position at once without using the cursor.

■ Top Line, End Line

This is the operation to move the cursor to the first line or the last line in the current window.

	Operation	Explanation
1	Select "TOP LINE" or "END LINE" under the pull down menu	The cursor moves to "TOP LINE" or "END LINE" of the window, then the selected line is displayed. <div data-bbox="774 488 1326 898" data-label="Image"> <p>The screenshot shows the 'USER LADDER' window with a menu bar (DATA, EDIT, DISPLAY, UTILITY) and a toolbar. The main area displays a list of ladder logic lines. The first line, '0000 0000 STR #20010', is highlighted with a black background. The rest of the window shows lines 0001 through 0007. At the bottom, there are 'Main Menu' and 'ShortCut' buttons.</p> </div>

■ Search for Line No. and Block No.

This is the operation to move the cursor to a line or a block in the current window.



	Operation	Explanation
1	Select "SEARCH LINE NO." or "SEARCH BLOCK NO." under the pull down menu	Numbers can be input.
2	Input a line No. or block No. using the NUMBER KEYS	
3	Press [ENTER]	The cursor moves to the entered line No. or block No., then the selected line or block is displayed. <div data-bbox="774 1451 1326 1861" data-label="Image"> <p>The screenshot shows the 'USER LADDER' window with a menu bar (DATA, EDIT, DISPLAY, UTILITY) and a toolbar. The main area displays a list of ladder logic lines. Line '0015 0008 OUT #70030' is highlighted with a black background. The rest of the window shows lines 0012 through 0019. At the bottom, there are 'Main Menu' and 'ShortCut' buttons.</p> </div>

14 Editing Ladder Programs

14.3 Mnemonic Editing Window

■ Search for Relay No. and Register No.

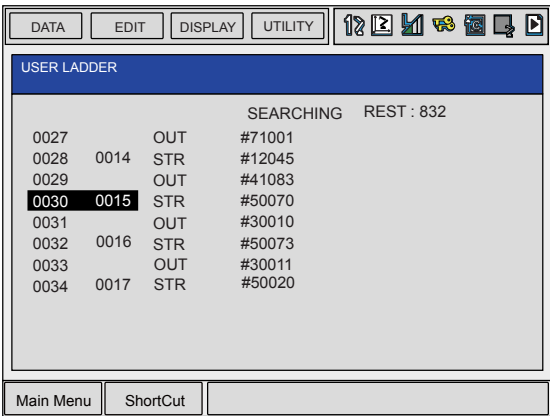
This is the operation to move the cursor to a relay No. or register line in the current window.

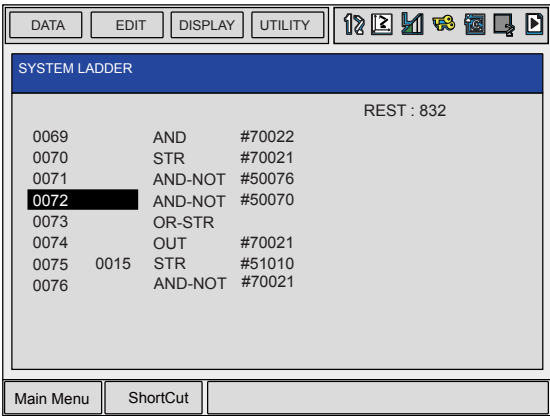
	Operation	Explanation
1	Select "SEARCH RELAY NO." or "SEARCH REGISTER NO." under the pull down menu	Numbers can be input.
2	Input a desired relay No. or register No. using the NUMBER KEYS	
3	Press [ENTER]	<p>The cursor moves to the entered relay No. or register No. and the selected relay or register is displayed.</p>  <p>While searching, "SEARCH" is displayed in the screen.</p>
4	Continues searching with the cursor	<p>In search status, forward and backward searching can be executed by [↓] and [↑] cursors.</p> <p>Press the PAGE KEY  to switch the window between the user ladder and the system ladder to continue searching. To end the search, press [Cancel] or move the cursor to the address area or the instruction area by using [→] and [←] cursors. The search status is canceled and the indication of "SEARCH" disappears.</p> 

15 Clearing Signals

By setting parameters, the signal status can be automatically cleared when the power is turned ON or the mode is changed.

15.1 Clearing the Universal Output Signals

■ Clearing Signals when Powering ON

Set the parameter S2C187 to specify whether to collectively clear the universal output signals (1024 points) when powering ON, or to hold the signals in the statuses when powering OFF.

Parameter	Signal	Setting Value
S2C187	#10010 - #11287 (Collective setting)	0: Hold; 1: Clear <div style="border: 1px solid black; padding: 5px; width: fit-content;"> If S2C187 is set to "1", all the statuses of the universal output signals become OFF when the power is turned ON. </div>

■ Clearing Signals when Changing the Teach/Play Mode

Set the parameters S4C032 - S4C039 to specify whether to clear the universal output signals when changing modes, or to hold the signal statuses. (Every 8 points; 0: hold; 1: clear)

Parameter	Signal	Setting Value
S4C032	d00: #10010 - #10017, d01: #10020 - #10027 d02: #10030 - #10037, d03: #10040 - #10047 d04: #10050 - #10057, d05: #10060 - #10067 d06: #10070 - #10077, d07: #10080 - #10087 d08: #10090 - #10097, d09: #10100 - #10107 d10: #10110 - #10117, d11: #10120 - #10127 d12: #10130 - #10137, d13: #10140 - #10147 d14: #10150 - #10157, d15: #10160 - #10167	Bit specified in every 8 points 0: Hold; 1: Clear <div style="border: 1px solid black; padding: 5px; width: fit-content;"> The universal output signals whose specified bit is set to "1" will be in the "OFF" status when the mode is changed. </div>
S4C033	d00: #10170 - #10177, d01: #10180 - #10187 d02: #10190 - #10197, d03: #10200 - #10207 d04: #10210 - #10217, d05: #10220 - #10227 d06: #10230 - #10237, d07: #10240 - #10247 d08: #10250 - #10257, d09: #10260 - #10267 d10: #10270 - #10277, d11: #10280 - #10287 d12: #10290 - #10297, d13: #10300 - #10307 d14: #10310 - #10317, d15: #10320 - #10327	

15 Clearing Signals

15.1 Clearing the Universal Output Signals

Parameter	Signal	Setting Value
S4C034	d00: #10330 - #10337, d02: #10350 - #10357, d04: #10370 - #10377, d06: #10390 - #10397, d08: #10410 - #10417, d10: #10430 - #10437, d12: #10450 - #10457, d14: #10470 - #10477, d01: #10340 - #10347 d03: #10360 - #10367 d05: #10380 - #10387 d07: #10400 - #10407 d09: #10420 - #10427 d11: #10440 - #10447 d13: #10460 - #10467 d15: #10480 - #10487	Bit specified in every 8 points 0: Hold; 1: Clear <div style="border: 1px solid black; padding: 5px; width: fit-content;"> <p>The universal output signals whose specified bit is set to "1" will be in the "OFF" status when the mode is changed.</p> </div>
S4C035	d00: #10490 - #10497, d02: #10510 - #10517, d04: #10530 - #10537, d06: #10550 - #10557, d08: #10570 - #10577, d10: #10590 - #10597, d12: #10610 - #10617, d14: #10630 - #10637, d01: #10500 - #10507 d03: #10520 - #10527 d05: #10540 - #10547 d07: #10560 - #10567 d09: #10580 - #10587 d11: #10600 - #10607 d13: #10620 - #10627 d15: #10640 - #10647	
S4C036	d00: #10650 - #10657, d02: #10670 - #10677, d04: #10690 - #10697, d06: #10710 - #10717, d08: #10730 - #10737, d10: #10750 - #10757, d12: #10770 - #10777, d14: #10790 - #10797, d01: #10660 - #10667 d03: #10680 - #10687 d05: #10700 - #10707 d07: #10720 - #10727 d09: #10740 - #10747 d11: #10760 - #10767 d13: #10780 - #10787 d15: #10800 - #10807	
S4C037	d00: #10810 - #10817, d02: #10830 - #10837, d04: #10850 - #10857, d06: #10870 - #10877, d08: #10890 - #10897, d10: #10910 - #10917, d12: #10930 - #10937, d14: #10950 - #10957, d01: #10820 - #10827 d03: #10840 - #10847 d05: #10860 - #10867 d07: #10880 - #10887 d09: #10900 - #10907 d11: #10920 - #10927 d13: #10940 - #10947 d15: #10960 - #10967	
S4C038	d00: #10970 - #10977, d02: #10990 - #10997, d04: #11010 - #11017, d06: #11030 - #11037, d08: #11050 - #11057, d10: #11070 - #11077, d12: #11090 - #11097, d14: #11110 - #11117, d01: #10980 - #10987 d03: #11000 - #11007 d05: #11020 - #11027 d07: #11040 - #11047 d09: #11060 - #11067 d11: #11080 - #11087 d13: #11100 - #11107 d15: #11120 - #11127	
S4C039	d00: #11130 - #11137, d02: #11150 - #11157, d04: #11170 - #11177, d06: #11190 - #11197, d08: #11210 - #11217, d10: #11230 - #11237, d12: #11250 - #11257, d14: #11270 - #11277, d01: #11140 - #11147 d03: #11160 - #11167 d05: #11180 - #11187 d07: #11200 - #11207 d09: #11220 - #11227 d11: #11240 - #11247 d13: #11260 - #11267 d15: #11280 - #11287	

15.2 Clearing the Interface Panel Signals

■ Clearing Signals when Powering ON

Set the parameters S4C330 - S4C333 to specify whether to clear the interface panel signals when powering ON, or to hold the signals in the statuses when powering OFF. (Every 8 points; 0: hold; 1: clear)

Parameter	Signal	Setting Value
S4C330	d00: #60010 - #60017, d01: #60020 - #60027 d02: #60030 - #60037, d03: #60040 - #60047 d04: #60050 - #60057, d05: #60060 - #60067 d06: #60070 - #60077, d07: #60080 - #60087 d08: #60090 - #60097, d09: #60100 - #60107 d10: #60110 - #60117, d11: #60120 - #60127 d12: #60130 - #60137, d13: #60140 - #60147 d14: #60150 - #60157, d15: #60160 - #60167	Bit specified in every 8 points 0: Hold; 1: Clear <div style="border: 1px solid black; padding: 5px; width: fit-content;"> The interface panel signals whose specified bit is set to "1" will be in the "OFF" status when the power is ON. </div>
S4C331	d00: #60170 - #60177, d01: #60180 - #60187 d02: #60190 - #60197, d03: #60200 - #60207 d04: #60210 - #60217, d05: #60220 - #60227 d06: #60230 - #60237, d07: #60240 - #60247 d08: #60250 - #60257, d09: #60260 - #60267 d10: #60270 - #60277, d11: #60280 - #60287 d12: #60290 - #60297, d13: #60300 - #60307 d14: #60310 - #60317, d15: #60320 - #60327	
S4C332	d00: #60330 - #60337, d01: #60340 - #60347 d02: #60350 - #60357, d03: #60360 - #60367 d04: #60370 - #60377, d05: #60380 - #60387 d06: #60390 - #60397, d07: #60400 - #60407 d08: #60410 - #60417, d09: #60420 - #60427 d10: #60430 - #60437, d11: #60440 - #60447 d12: #60450 - #60457, d13: #60460 - #60467 d14: #60470 - #60477, d15: #60480 - #60487	
S4C333	d00: #60490 - #60497, d01: #60500 - #60507 d02: #60510 - #60517, d03: #60520 - #60527 d04: #60530 - #60537, d05: #60540 - #60547 d06: #60550 - #60557, d07: #60560 - #60567 d08: #60570 - #60577, d09: #60580 - #60587 d10: #60590 - #60597, d11: #60600 - #60607 d12: #60610 - #60617, d13: #60620 - #60627 d14: #60630 - #60637, d15: #60640 - #60647	

15 Clearing Signals

15.3 Clearing the Auxiliary Relay Signals

15.3 Clearing the Auxiliary Relay Signals

■ Clearing Signals when Powering ON

Set the parameters S4C040 - S4C055 to specify whether to clear the auxiliary relay signals when powering ON, or to hold the signals in the statuses when powering OFF.

(Every 32 points; 0: clear; 1: hold)

Parameter	Signal	Setting Value
S4C040	d00: #70010 - #70047, d01: #70050 - #70087 d02: #70090 - #70127, d03: #70130 - #70167 d04: #70170 - #70207, d05: #70210 - #70247 d06: #70250 - #70287, d07: #70290 - #70327 d08: #70330 - #70367, d09: #70370 - #70407 d10: #70410 - #70447, d11: #70450 - #70487 d12: #70490 - #70527, d13: #70530 - #70567 d14: #70570 - #70607, d15: #70610 - #70647	Bit specified in every 32 points 0: Clear; 1: Hold
S4C041	d00: #70650 - #70687, d01: #70690 - #70727 d02: #70730 - #70767, d03: #70770 - #70807 d04: #70810 - #70847, d05: #70850 - #70887 d06: #70890 - #70927, d07: #70930 - #70967 d08: #70970 - #71007, d09: #71010 - #71047 d10: #71050 - #71087, d11: #71090 - #71127 d12: #71130 - #71167, d13: #71170 - #71207 d14: #71210 - #71247, d15: #71250 - #71287	<div style="border: 1px solid black; padding: 5px;"> <p>The auxiliary relay signals whose specified bit is set to "1" will be in the "hold" status when the power is ON.</p> </div>
S4C042	d00: #71290 - #71327, d01: #71330 - #71367 d02: #71370 - #71407, d03: #71410 - #71447 d04: #71450 - #71487, d05: #71490 - #71527 d06: #71530 - #71567, d07: #71570 - #71607 d08: #71610 - #71647, d09: #71650 - #71687 d10: #71690 - #71727, d11: #71730 - #71767 d12: #71770 - #71807, d13: #71810 - #71847 d14: #71850 - #71887, d15: #71890 - #71927	
S4C043	d00: #71930 - #71967, d01: #71970 - #72007 d02: #72010 - #72047, d03: #72050 - #72087 d04: #72090 - #72127, d05: #72130 - #72167 d06: #72170 - #72207, d07: #72210 - #72247 d08: #72250 - #72287, d09: #72290 - #72327 d10: #72330 - #72367, d11: #72370 - #72407 d12: #72410 - #72447, d13: #72450 - #72487 d14: #72490 - #72527, d15: #72530 - #72567	
S4C044	d00: #72570 - #72607, d01: #72610 - #72647 d02: #72650 - #72687, d03: #72690 - #72727 d04: #72730 - #72767, d05: #72770 - #72807 d06: #72810 - #72847, d07: #72850 - #72887 d08: #72890 - #72927, d09: #72930 - #72967 d10: #72970 - #73007, d11: #73010 - #73047 d12: #73050 - #73087, d13: #73090 - #73127 d14: #73130 - #73167, d15: #73170 - #73207	

Parameter	Signal	Setting Value
S4C045	d00: #73210 - #73247, d01: #73250 - #73287 d02: #73290 - #73327, d03: #73330 - #73367 d04: #73370 - #73407, d05: #73410 - #73447 d06: #73450 - #73487, d07: #73490 - #73527 d08: #73530 - #73567, d09: #73570 - #73607 d10: #73610 - #73647, d11: #73650 - #73687 d12: #73690 - #73727, d13: #73730 - #73767 d14: #73770 - #73807, d15: #73810 - #73847	Bit specified in every 32 points 0: Clear; 1: Hold <div style="border: 1px solid black; padding: 5px; width: fit-content;"> <p>The auxiliary relay signals whose specified bit is set to "1" will be in the "hold" status when the power is ON.</p> </div>
S4C046	d00: #73850 - #73887, d01: #73890 - #73927 d02: #73930 - #73967, d03: #73970 - #74007 d04: #74010 - #74047, d05: #74050 - #74087 d06: #74090 - #74127, d07: #74130 - #74167 d08: #74170 - #74207, d09: #74210 - #74247 d10: #74250 - #74287, d11: #74290 - #74327 d12: #74330 - #74367, d13: #74370 - #74407 d14: #74410 - #74447, d15: #74450 - #74487	
S4C047	d00: #74490 - #74527, d01: #74530 - #74567 d02: #74570 - #74607, d03: #74610 - #74647 d04: #74650 - #74687, d05: #74690 - #74727 d06: #74730 - #74767, d07: #74770 - #74807 d08: #74810 - #74847, d09: #74850 - #74887 d10: #74890 - #74927, d11: #74930 - #74967 d12: #74970 - #75007, d13: #75010 - #75047 d14: #75050 - #75087, d15: #75090 - #75127	
S4C048	d00: #75130 - #75167, d01: #75170 - #75207 d02: #75210 - #75247, d03: #75250 - #75287 d04: #75290 - #75327, d05: #75330 - #75367 d06: #75370 - #75407, d07: #75410 - #75447 d08: #75450 - #75487, d09: #75490 - #75527 d10: #75530 - #75567, d11: #75570 - #75607 d12: #75610 - #75647, d13: #75650 - #75687 d14: #75690 - #75727, d15: #75730 - #75767	
S4C049	d00: #75770 - #75807, d01: #75810 - #75847 d02: #75850 - #75887, d03: #75890 - #75927 d04: #75930 - #75967, d05: #75970 - #76007 d06: #76010 - #76047, d07: #76050 - #76087 d08: #76090 - #76127, d09: #76130 - #76167 d10: #76170 - #76207, d11: #76210 - #76247 d12: #76250 - #76287, d13: #76290 - #76327 d14: #76330 - #76367, d15: #76370 - #76407	
S4C050	d00: #76410 - #76447, d01: #76450 - #76487 d02: #76490 - #76527, d03: #76530 - #76567 d04: #76570 - #76607, d05: #76610 - #76647 d06: #76650 - #76687, d07: #76690 - #76727 d08: #76730 - #76767, d09: #76770 - #76807 d10: #76810 - #76847, d11: #76850 - #76887 d12: #76890 - #76927, d13: #76930 - #76967 d14: #76970 - #77007, d15: #77010 - #77047	

15 Clearing Signals

15.3 Clearing the Auxiliary Relay Signals

Parameter	Signal	Setting Value
S4C051	d00: #77050 - #77087, d01: #77090 - #77127 d02: #77130 - #77167, d03: #77170 - #77207 d04: #77210 - #77247, d05: #77250 - #77287 d06: #77290 - #77327, d07: #77330 - #77367 d08: #77370 - #77407, d09: #77410 - #77447 d10: #77450 - #77487, d11: #77490 - #77527 d12: #77530 - #77567, d13: #77570 - #77607 d14: #77610 - #77647, d15: #77650 - #77687	Bit specified in every 32 points 0: Clear; 1: Hold
S4C052	d00: #77690 - #77727, d01: #77730 - #77767 d02: #77770 - #77807, d03: #77810 - #77847 d04: #77850 - #77887, d05: #77890 - #77927 d06: #77930 - #77967, d07: #77970 - #78007 d08: #78010 - #78047, d09: #78050 - #78087 d10: #78090 - #78127, d11: #78130 - #78167 d12: #78170 - #78207, d13: #78210 - #78247 d14: #78250 - #78287, d15: #78290 - #78327	<div style="border: 1px solid black; padding: 5px;"> <p>The auxiliary relay signals whose specified bit is set to "1" will be in the "hold" status when the power is ON.</p> </div>
S4C053	d00: #78330 - #78367, d01: #78370 - #78407 d02: #78410 - #78447, d03: #78450 - #78487 d04: #78490 - #78527, d05: #78530 - #78567 d06: #78570 - #78607, d07: #78610 - #78647 d08: #78650 - #78687, d09: #78690 - #78727 d10: #78730 - #78767, d11: #78770 - #78807 d12: #78810 - #78847, d13: #78850 - #78887 d14: #78890 - #78927, d15: #78930 - #78967	
S4C054	d00: #78970 - #79007, d01: #79010 - #79047 d02: #79050 - #79087, d03: #79090 - #79127 d04: #79130 - #79167, d05: #79170 - #79207 d06: #79210 - #79247, d07: #79250 - #79287 d08: #79290 - #79327, d09: #79330 - #79367 d10: #79370 - #79407, d11: #79410 - #79447 d12: #79450 - #79487, d13: #79490 - #79527 d14: #79530 - #79567, d15: #79570 - #79607	
S4C055	d00: #79610 - #79647, d01: #79650 - #79687 d02: #79690 - #79727, d03: #79730 - #79767 d04: #79770 - #79807, d05: #79810 - #79847 d06: #79850 - #79887, d07: #79890 - #79927 d08: #79930 - #79967, d09: #79970 - #79997	

15.4 Clearing the Universal Register

■ Clearing Registers when Powering ON

Set the parameters S4C245 - S4C261 to specify whether to clear the universal registers when powering ON, or to hold the signals in the statuses when powering OFF.
(Every 1 point; 0: hold; 1: clear)

Parameter	Signal	Setting Value
S4C245	d00: M000 d01: M001 d02: M002 d03: M003 d04: M004 d05: M005 d06: M006 d07: M007 d08: M008 d09: M009 d10: M010 d11: M011 d12: M012 d13: M013 d14: M014 d15: M015	Bit specified in every 1 point 0: Hold; 1: Clear <div style="border: 1px solid black; padding: 5px; width: fit-content;"> The values of the universal registers whose specified bit is set to 1 will be "0" when the power is ON. </div>
S4C246	d00: M016 d01: M017 d02: M018 d03: M019 d04: M020 d05: M021 d06: M022 d07: M023 d08: M024 d09: M025 d10: M026 d11: M027 d12: M028 d13: M029 d14: M030 d15: M031	
S4C247	d00: M032 d01: M033 d02: M034 d03: M035 d04: M036 d05: M037 d06: M038 d07: M039 d08: M040 d09: M041 d10: M042 d11: M043 d12: M044 d13: M045 d14: M046 d15: M047	
S4C248	d00: M048 d01: M049 d02: M050 d03: M051 d04: M052 d05: M053 d06: M054 d07: M055 d08: M056 d09: M057 d10: M058 d11: M059 d12: M060 d13: M061 d14: M062 d15: M063	
S4C249	d00: M064 d01: M065 d02: M066 d03: M067 d04: M068 d05: M069 d06: M070 d07: M071 d08: M072 d09: M073 d10: M074 d11: M075 d12: M076 d13: M077 d14: M078 d15: M079	
S4C250	d00: M080 d01: M081 d02: M082 d03: M083 d04: M084 d05: M085 d06: M086 d07: M087 d08: M088 d09: M089 d10: M090 d11: M091 d12: M092 d13: M093 d14: M094 d15: M095	
S4C251	d00: M096 d01: M097 d02: M098 d03: M099 d04: M100 d05: M101 d06: M102 d07: M103 d08: M104 d09: M105 d10: M106 d11: M107 d12: M108 d13: M109 d14: M110 d15: M111	
S4C252	d00: M112 d01: M113 d02: M114 d03: M115 d04: M116 d05: M117 d06: M118 d07: M119 d08: M120 d09: M121 d10: M122 d11: M123 d12: M124 d13: M125 d14: M126 d15: M127	
S4C253	d00: M128 d01: M129 d02: M130 d03: M131 d04: M132 d05: M133 d06: M134 d07: M135 d08: M136 d09: M137 d10: M138 d11: M139 d12: M140 d13: M141 d14: M142 d15: M143	

15 Clearing Signals

15.4 Clearing the Universal Register

Parameter	Signal	Setting Value
S4C254	d00: M144 d01: M145 d02: M146 d03: M147 d04: M148 d05: M149 d06: M150 d07: M151 d08: M152 d09: M153 d10: M154 d11: M155 d12: M156 d13: M157 d14: M158 d15: M159	Bit specified in every 1 point 0: Hold; 1: Clear <div style="border: 1px solid black; padding: 5px; width: fit-content;"> The values of the universal registers whose specified bit is set to 1 will be "0" when the power is ON. </div>
S4C255	d00: M160 d01: M161 d02: M162 d03: M163 d04: M164 d05: M165 d06: M166 d07: M167 d08: M168 d09: M169 d10: M170 d11: M171 d12: M172 d13: M173 d14: M174 d15: M175	
S4C256	d00: M176 d01: M177 d02: M178 d03: M179 d04: M180 d05: M181 d06: M182 d07: M183 d08: M184 d09: M185 d10: M186 d11: M187 d12: M188 d13: M189 d14: M190 d15: M191	
S4C257	d00: M192 d01: M193 d02: M194 d03: M195 d04: M196 d05: M197 d06: M198 d07: M199 d08: M200 d09: M201 d10: M202 d11: M203 d12: M204 d13: M205 d14: M206 d15: M207	
S4C258	d00: M208 d01: M209 d02: M210 d03: M211 d04: M212 d05: M213 d06: M214 d07: M215 d08: M216 d09: M217 d10: M218 d11: M219 d12: M220 d13: M221 d14: M222 d15: M223	
S4C259	d00: M224 d01: M225 d02: M226 d03: M227 d04: M228 d05: M229 d06: M230 d07: M231 d08: M232 d09: M233 d10: M234 d11: M235 d12: M236 d13: M237 d14: M238 d15: M239	
S4C260	d00: M240 d01: M241 d02: M242 d03: M243 d04: M244 d05: M245 d06: M246 d07: M247 d08: M248 d09: M249 d10: M250 d11: M251 d12: M252 d13: M253 d14: M254 d15: M255	
S4C261	d00: M256 d01: M257 d02: M258 d03: M259	

NX100

Concurrent I/O

HEAD OFFICE

2-1 Kurosakishiroishi, Yahatanishi-ku, Kitakyushu 806-0004, Japan
Phone +81-93-645-7703 Fax +81-93-645-7802

YASKAWA America Inc. (Motoman Robotics Division)
100 Automation Way, Miamisburg, OH 45342, U.S.A.
Phone +1-937-847-6200 Fax +1-937-847-6277

YASKAWA Europe GmbH (Robotics Division)
Yaskawastrasse 1, 85391 Allershausen, Germany
Phone +49-8166-90-100 Fax +49-8166-90-103

YASKAWA Nordic AB
Bredbandet 1 vån. 3 varvsholmen 392 30 Kalmar, Sweden
Phone +46-480-417-800 Fax +46-480-417-999

YASKAWA Electric (China) Co., Ltd.
22/F One Corporate Avenue No.222, Hubin Road, Huangpu District, Shanghai 200021, China
Phone +86-21-5385-2200 Fax +86-21-5385-3299

YASKAWA SHOUGANG ROBOT Co. Ltd.
No7 Yongchang North Road, Beijing E&T Development Area, China 100176
Phone +86-10-6788-2858 Fax +86-10-6788-2878

YASKAWA India Private Ltd. (Robotics Division)
#426, Udyog Vihar, Phase- IV, Gurgaon, Haryana, India
Phone +91-124-475-8500 Fax +91-124-475-8542

YASKAWA Electric Korea Co., Ltd
9F, Kyobo Securities Bldg., 26-4, Yeouido-dong, Yeongdeungpo-gu, Seoul 150-737, Korea
Phone +82-2-784-7844 Fax +82-2-784-8495

YASKAWA Electric Taiwan Corporation
12F, No.207, Sec. 3, Beishin Rd., Shindian District, New Taipei City 23143, Taiwan
Phone +886-2-8913-1333 Fax +886-2-8913-1513

YASKAWA Electric (Singapore) PTE Ltd.
151 Lorong Chuan, #04-02A, New Tech Park, Singapore 556741
Phone +65-6282-3003 Fax +65-6289-3003

YASKAWA Electric (Thailand) Co., Ltd.
59,1st-5th Floor, Flourish Building, Soi Ratchadapisek 18,Ratchadapisek Road,
Huaykwang, Bangkok 10310, THAILAND
Phone +66-2-017-0099 Fax +66-2-017-0199

PT. YASKAWA Electric Indonesia
Secure Building-Gedung B Lantai Dasar & Lantai 1 Jl. Raya Protokol Halim Perdanakusuma,
Jakarta 13610, Indonesia
Phone +62-21-2982-6470 Fax +62-21-2982-6741

Specifications are subject to change without notice
for ongoing product modifications and improvements.