

- 24-hour Telephone Number: (937) 847-3200
Use for urgent or emergency needs for technical support, service and/or replacement parts
- Routine Technical Inquiries: techsupport@motoman.com
Allow up to 36 hours for response

YRC1000 OPTIONS INSTRUCTIONS

FOR I/O OUTPUT TIMING CONTROL FUNCTION

Upon receipt of the product and prior to initial operation, read these instructions thoroughly, and retain for future reference.

MOTOMAN INSTRUCTIONS

MOTOMAN-□□□ INSTRUCTIONS
YRC1000 INSTRUCTIONS
YRC1000 OPERATOR'S MANUAL (GENERAL) (SUBJECT SPECIFIC)
YRC1000 MAINTENANCE MANUAL
YRC1000 ALARM CODES (MAJOR ALARMS) (MINOR ALARMS)

The YRC1000 operator's manual above corresponds to specific usage. Be sure to use the appropriate manual.
The YRC1000 operator's manual above consists of "GENERAL" and "SUBJECT SPECIFIC".
The YRC1000 alarm codes above consists of "MAJOR ALARMS" and "MINOR ALARMS".

Please have the following information available when contacting Yaskawa Customer Support:

- System
- Primary Application
- Software Version (*Located on Programming Pendant by selecting: {Main Menu} - {System Info} - {Version}*)
Robot Serial Number (*Located on robot data plate*)
Robot Sales Order Number (*Located on controller data plate*)

Part Number: 178677-1CD
Revision: 0



DANGER

- This manual explains the I/O output timing control function of the YRC1000 system. Read this manual carefully and be sure to understand its contents before handling the YRC1000. Any matter not described in this manual must be regarded as "prohibited" or "improper".
- General information related to safety are described in "Chapter 1. Safety" of the YRC1000 INSTRUCTIONS. To ensure correct and safe operation, carefully read "Chapter 1. Safety" of the YRC1000 INSTRUCTIONS.



CAUTION

- In some drawings in this manual, protective covers or shields are removed to show details. Make sure that all the covers or shields are installed in place before operating this product.
- YASKAWA is not responsible for incidents arising from unauthorized modification of its products. Unauthorized modification voids the product warranty.

NOTICE

- The drawings and photos in this manual are representative examples and differences may exist between them and the delivered product.
- YASKAWA may modify this model without notice when necessary due to product improvements, modifications, or changes in specifications. If such modification is made, the manual number will also be revised.
- If your copy of the manual is damaged or lost, contact a YASKAWA representative to order a new copy. The representatives are listed on the back cover. Be sure to tell the representative the manual number listed on the front cover.

NOTES FOR SAFE OPERATION

Read this manual carefully before installation, operation, maintenance, or inspection of the YRC1000.

In this manual, the Notes for Safe Operation are classified as “DANGER”, “WARNING”, “CAUTION”, or “NOTICE”.



DANGER

Indicates an imminently hazardous situation which, if not avoided, will result in death or serious injury. Safety Signs identified by the signal word DANGER should be used sparingly and only for those situations presenting the most serious hazards.



WARNING

Indicates a potentially hazardous situation which, if not avoided, will result in death or serious injury. Hazards identified by the signal word WARNING present a lesser degree of risk of injury or death than those identified by the signal word DANGER.



CAUTION

Indicates a hazardous situation, which if not avoided, could result in minor or moderate injury. It may also be used without the safety alert symbol as an alternative to “NOTICE”.

NOTICE

NOTICE is the preferred signal word to address practices not related to personal injury. The safety alert symbol should not be used with this signal word. As an alternative to “NOTICE”, the word “CAUTION” without the safety alert symbol may be used to indicate a message not related to personal injury.

Even items described as “CAUTION” may result in a serious accident in some situations.

At any rate, be sure to follow these important items.



To ensure safe and efficient operation at all times, be sure to follow all instructions, even if not designated as “DANGER”, “WARNING” and “CAUTION”.



DANGER

- Before operating the manipulator, make sure the servo power is turned OFF by performing the following operations. When the servo power is turned OFF, the SERVO ON LED on the programming pendant is turned OFF.
 - Press the emergency stop buttons on the front door of the YRC1000, on the programming pendant, on the external control device, etc.
 - Disconnect the safety plug of the safety fence. (when in the play mode or in the remote mode)

If operation of the manipulator cannot be stopped in an emergency, personal injury and/or equipment damage may result.

Fig. : Emergency Stop Button



- Before releasing the emergency stop, make sure to remove the obstacle or error caused the emergency stop, if any, and then turn the servo power ON.

Failure to observe this instruction may cause unintended movement of the manipulator, which may result in personal injury.

Fig. : Release of Emergency Stop



- Observe the following precautions when performing a teaching operation within the manipulator's operating range:
 - Be sure to perform lockout by putting a lockout device on the safety fence when going into the area enclosed by the safety fence. In addition, the operator of the teaching operation must display the sign that the operation is being performed so that no other person closes the safety fence.
 - View the manipulator from the front whenever possible.
 - Always follow the predetermined operating procedure.
 - Always keep in mind emergency response measures against the manipulator's unexpected movement toward a person.
 - Ensure a safe place to retreat in case of emergency.

Failure to observe this instruction may cause improper or unintended movement of the manipulator, which may result in personal injury.

- Confirm that no person is present in the manipulator's operating range and that the operator is in a safe location before:
 - Turning ON the YRC1000 power
 - Moving the manipulator by using the programming pendant
 - Running the system in the check mode
 - Performing automatic operations

Personal injury may result if a person enters the manipulator's operating range during operation. Immediately press an emergency stop button whenever there is a problem. The emergency stop buttons are located on the front panel of the YRC1000 and on the right of the programming pendant.

- Read and understand the Explanation of the Warning Labels before operating the manipulator.



WARNING

- Perform the following inspection procedures prior to conducting manipulator teaching. If there is any problem, immediately take necessary steps to solve it, such as maintenance and repair.
 - Check for a problem in manipulator movement.
 - Check for damage to insulation and sheathing of external wires.
- Always return the programming pendant to the hook on the YRC1000 cabinet after use.

If the programming pendant is left unattended on the manipulator, on a fixture, or on the floor, etc., the Enable Switch may be activated due to surface irregularities of where it is left, and the servo power may be turned ON. In addition, in case the operation of the manipulator starts, the manipulator or the tool may hit the programming pendant left unattended, which may result in personal injury and/or equipment damage.

Definition of Terms Used Often in This Manual

The MOTOMAN is the YASKAWA industrial robot product.

The MOTOMAN usually consists of the manipulator, the controller, the programming pendant, and supply cables.

In this manual, the equipment is designated as follows.

Equipment	Manual Designation
YRC1000 controller	YRC1000
YRC1000 programming pendant	Programming pendant
Cable between the manipulator and the controller	Manipulator cable

Descriptions of the programming pendant keys, buttons, and displays are shown as follows:

Equipment		Manual Designation
Programming Pendant	Character Keys /Symbol Keys	The keys which have characters or its symbol printed on them are denoted with []. ex. [ENTER]
	Axis Keys /Numeric Keys	[Axis Key] and [Numeric Key] are generic names for the keys for axis operation and number input.
	Keys pressed simultaneously	When two keys are to be pressed simultaneously, the keys are shown with a "+" sign between them, ex. [SHIFT]+[COORD]
	Displays	The menu displayed in the programming pendant is denoted with { }. ex. {JOB}

Description of the Operation Procedure

In the explanation of the operation procedure, the expression "Select •••" means that the cursor is moved to the object item and [SELECT] is pressed, or that the item is directly selected by touching the screen.

Registered Trademark

In this manual, names of companies, corporations, or products are trademarks, registered trademarks, or brand names for each company or corporation. The indications of (R) and TM are omitted.

Contents

1	About I/O Output Timing Control Function.....	1-1
2	Setup of I/O Output Timing Control Function.....	2-1
2.1	Instruction of I/O Output Timing Control Function	2-1
2.1.1	Configuration of Synchronized Signal Output Instruction.....	2-1
2.1.2	Configuration of +DOUT Instruction	2-2
2.1.3	Registration of +DOUT Instruction	2-4
2.1.4	Configuration of +PULSE Instruction.....	2-8
2.1.5	Registration of +PULSE Instruction.....	2-10
2.2	Device Response Delay Time Compensate Parameter	2-14
2.3	Signal Output Control Parameter During the FWD Operation.....	2-14
2.4	Notes	2-14
2.5	The Examples of the I/O Output Timing Specifying Function.....	2-16

1 About I/O Output Timing Control Function

I/O output timing control function is a function that can adjust the timing of general output signal by distance or time which based on the teaching position for the move instruction.

When the manipulator reaches to the specifying point which specified the time or distance while the manipulator is operating the move instruction, this function can output the general output signal. This function can adjust to deviation of work timing from the operation delay of the manipulator or devices which controlled by general output signal such as, valve and cylinder. Therefore, the manipulator can operate correctly, when it reaches to the expected position.

Fig. 1-1: I/O Output Timing Control Function

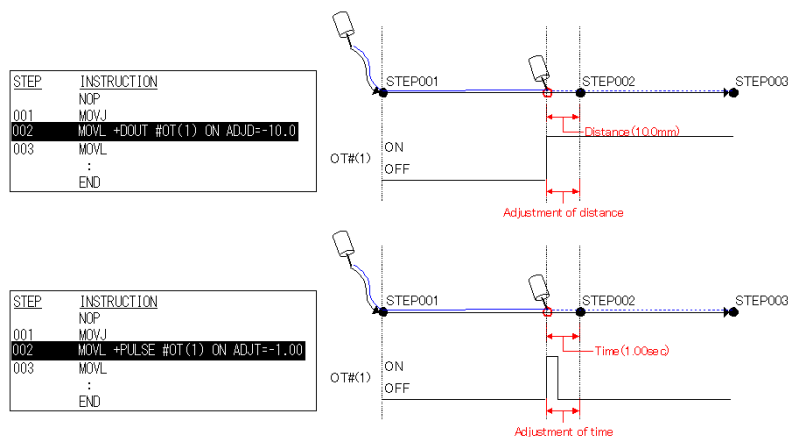

In case of the signal output is specified as distance, and the manipulator does not reach to the signal output position, such as the movement of the inward turning operation, the signal will be output when the manipulator comes to closest approach.

NOTE

STEP	INSTRUCTION
001	NOP
002	MOVJ +DOUT #OT(1) ON ADJ=0.0
003	MOVL
	:
	END

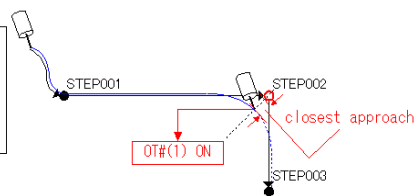

2 Setup of I/O Output Timing Control Function

2.1 Instruction of I/O Output Timing Control Function

2.1.1 Configuration of Synchronized Signal Output Instruction at Move Instruction

On the I/O output timing control function, as shown at *table 2-1 "Configuration of Synchronized Output Signal"*. The synchronized signal output instruction (+DOUT/+PULSE) added to the move instruction will output the general output signal. The configuration of instruction is shown as follows.

Fig. 2-1: Configuration of Synchronized Output Signal

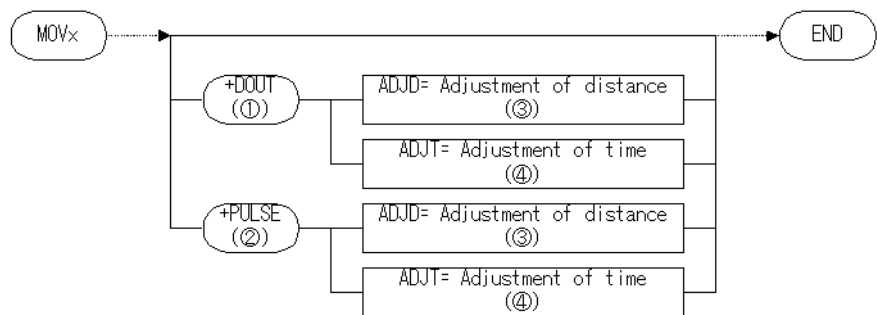

- ① +DOUT
Synchronized signal output instruction
- ② +PULSE
Synchronized pulse output instruction
- ③ ADJD=
Adjustment distance tag (setting data range: -3276.8 to 3276.7[mm])
- ④ ADJT=
Adjustment time tag (setting data range: -3276.8 to 327.67[mm])

NOTE

The synchronized signal output instruction (+DOUT/+PULSE) can be added four move instructions, as follows
 MOVJ/MOVL/MOVC/IMOV

2 Setup of I/O Output Timing Control Function
 2.1 Instruction of I/O Output Timing Control Function

2.1.2 Configuration of +DOUT Instruction

+DOUT instruction which is added to the move instruction performs adjustment to the output timing of the general output signal.

The additional item of the +DOUT instruction is shown as follows.

Fig. 2-2: Configuration of +DOUT

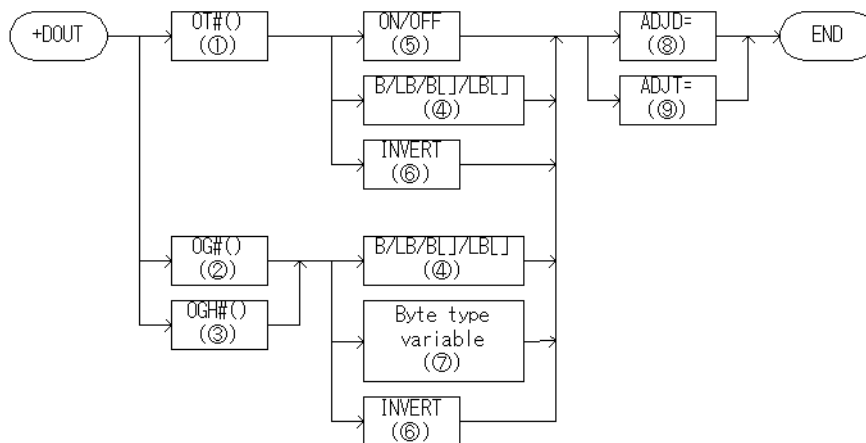

Choose of the tags from the following table

No	Tag	Explanation	Note
1	OT# (Output No.)	Specifies the output number signal.	No:1 to 4096 Variable B/I/D/LB/LI/LD can be used.
2	OG# (Output group No.)	Specifies the output number group signal (1group 8 points).	No:1 to 512 Variable B/I/D/LB/LI/LD can be used.
3	OGH# (Output group No.)	Specifies the output number group signal (1group 4 points).	No:1 to 1024 Variable B/I/D/LB/LI/LD can be used.

Output signal

Output signal OT#(x) is 1 point, OGH#(x) is 1 group 4 points, and OG#(x) is 1 group 8 points.



OT#(8)	OT#(7)	OT#(6)	OT#(5)	OT#(4)	OT#(3)	OT#(2)	OT#(1)
OGH#(2)				OGH#(1)			
OG#(1)							

No	Tag	Explanation	Note
4	B Variable number/ LB Variable number / B [Array number]/ LB [Array number]	The least significant bit of the specified byte type variable specifies ON/OFF of the output signal.	Least significant bit: 0: OFF 1: ON
5	ON/OFF	Specifies ON/OFF of the output signal.	
6	INVERT	Refers the current signal status to output OFF when the status is ON, and output ON when the status is OFF.	

2 Setup of I/O Output Timing Control Function

2.1 Instruction of I/O Output Timing Control Function

No	Tag	Explanation	Note
7	Byte type constant	When the constant byte type is expressed in bit form, the corresponding ON/OFF output signal is specified. Specifies ON/OFF of the output signal by bit value.	
8	ADJD	Based on the teaching position for the move instruction, specifies the distance to the signal output position. Performs the adjustment of distance as follows; specifying negative value to move the manipulator in the forward direction, and specifying positive value to move it in the backward direction. In case of specified [ADJD=0.0], the signal will be output when the manipulator passed the teaching position or comes to the closest approach.	No: -3276.8 to 3276.7 [mm] Variable B/I/D/LB/LI/LD can be used.



If specified adjustment distance from [ADJD=] is longer than the movement distance of the target step, the signal will be output at the moment of the cursor moves to the move instruction. Unable to adjust the signal output timing across the steps.

No	Tag	Explanation	Note
9	ADJT	Based on the teaching position for the move instruction, specifies the time to the signal output position. Performs the adjustment of time as follows; specifying negative value to move the manipulator in the forward direction, and specifying positive value to move it in the backward direction.	No: -327.68 to 327.67 [sec] Variable B/I/D/LB/LI/LD can be used.



If specified adjustment time from [ADJT=] is longer than the movement time of the target step, the signal will be output at the moment of the cursor moves to the move instruction. Unable to adjust the signal output timing across the steps.

2 Setup of I/O Output Timing Control Function

2.1 Instruction of I/O Output Timing Control Function

2.1.3 Registration of +DOUT Instruction

Perform the registration of instructions while the cursor is in the address area of the job content display on the teach mode.

1. Select {JOB} under the main menu.
2. Select {JOB CONTENT}.
3. Move the cursor to desired move instruction of the teaching position to register the +DOUT instruction.



4. Press [SELECT].
 - Move instruction appears in the input buffer line.



2 Setup of I/O Output Timing Control Function
 2.1 Instruction of I/O Output Timing Control Function

5. Changing additional item of the +DOUT instructions

- Move the cursor to the input buffer line, and then press the [SELECT] key to appear the detail edit display of the move instruction.

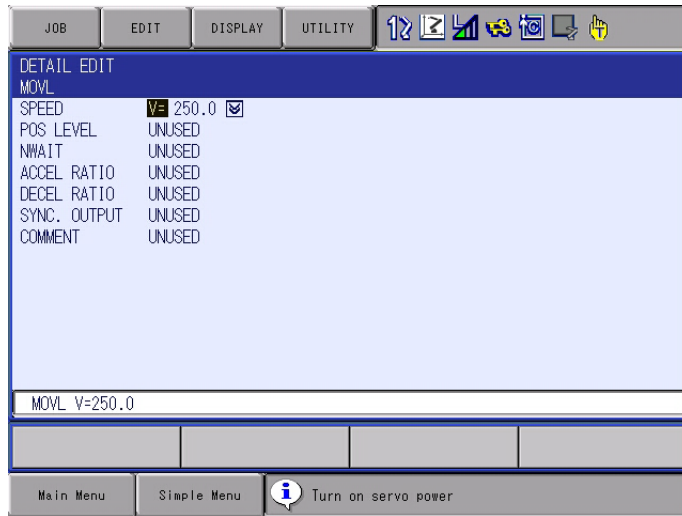

- Move the cursor to the [UNUSED] of the [SYNC. OUTPUT], and press [SELECT] key.



- When the selection dialog appears, select the [+DOUT] to display the detail edit display of the [+DOUT].

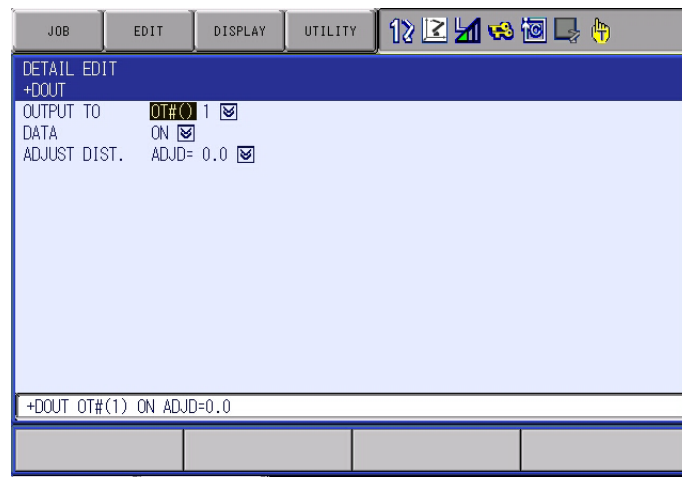

2 Setup of I/O Output Timing Control Function

2.1 Instruction of I/O Output Timing Control Function

- To change from [OUTPUT TO] to [OG#()] or [OGH#()], move the cursor to [OT#()] of [OUTPUT TO], and press [SELECT] key. The selection dialog will appear, then select [OG#()] or [OGH#()].

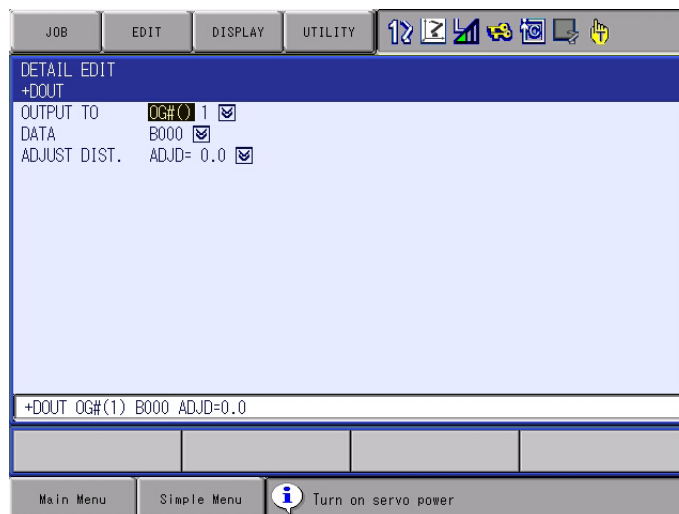

- To add [ADJUST TIME], move the cursor to [ADJ=], and press [SELECT] key. The selection dialog will appear, then select [ADJT=].

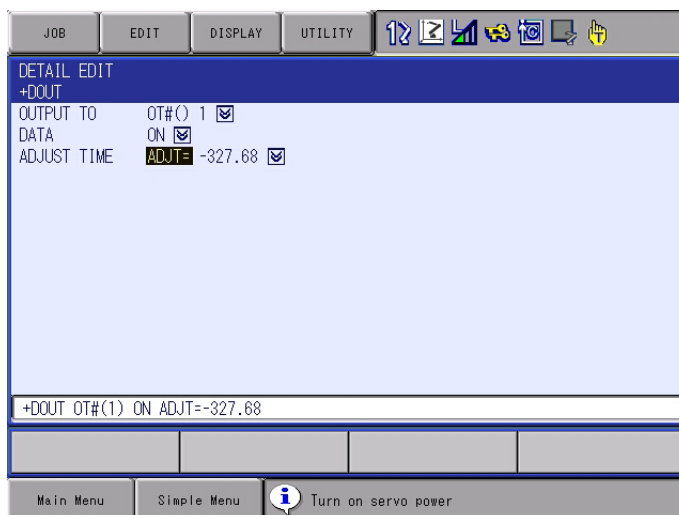

2 Setup of I/O Output Timing Control Function

2.1 Instruction of I/O Output Timing Control Function

- After adding or changing of additional items, and press [ENTER] key. The detail edit display of [+DOUT] will disappear, and the detail edit display of the move instruction will appear again.



- Press [ENTER] key, and the detail edit display of the move instruction will disappear. The job content display will appear.

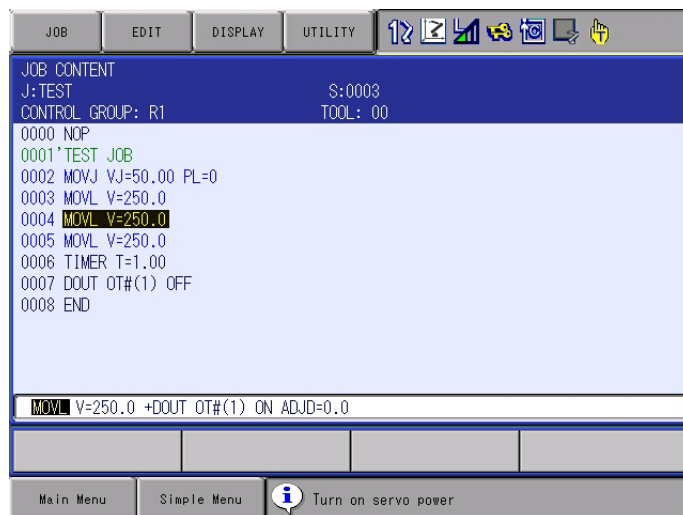

6. Press [ENTER] key.

- The instruction in the input buffer line will be registered.



2 Setup of I/O Output Timing Control Function
 2.1 Instruction of I/O Output Timing Control Function

2.1.4 Configuration of +PULSE Instruction

+PULSE instruction which is added to the move instruction performs adjustment to the pulse output timing of the general output signal.

The additional item of the +PULSE instruction is shown as follows.

Fig. 2-3: The Configuration of +PULSE Instruction

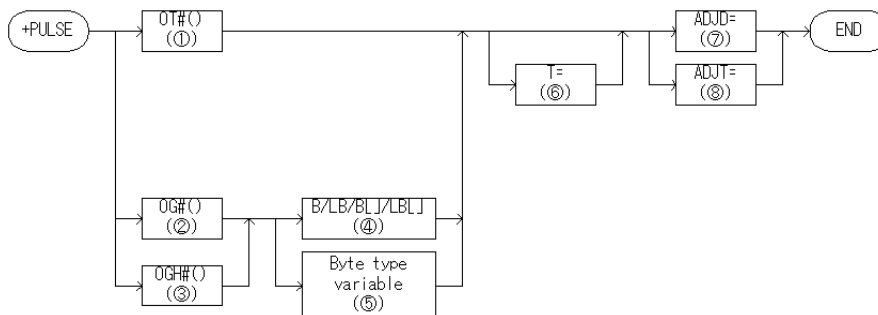

Choose one of the tags from the following table

No	Tag	Explanation	Note
1	OT# (Output No.)	Specifies the number of the signal to which the pulse signal is output.	No.: 1 to 4096 Variable B//D/LB/LI/LD can be used.
2	OG# (Output group No.)	Specifies the group number of the signal (1 group 8 points) to which the pulse signal is output.	No.: 1 to 512 Variable B//D/LB/LI/LD can be used.
3	OGH# (Output group No.)	Specifies the group number of the signal (1 group 4 points) to which the pulse signal is output.	No.: 1 to 1024 Variable B//D/LB/LI/LD can be used.

Output signal

Output signal OT#(x) is 1 point, OGH#(x) is 1 group 4 points, and OG#(x) is 1 group 8 points.



OT#(8)	OT#(7)	OT#(6)	OT#(5)	OT#(4)	OT#(3)	OT#(2)	OT#(1)
OGH#(2)				OGH#(1)			
OG#(1)							

2 Setup of I/O Output Timing Control Function

2.1 Instruction of I/O Output Timing Control Function

No.	Tag	Explanation	Note
4	B Variable number/ LB Variable number/ B [Array Number] / LB [Array Number]	Specifies the number of the corresponding pulse output signal when the contents of the specified byte type variable is expressed in bits.	Bit: 0: OFF 1: ON
5	Byte type constant	Specifies the number of the corresponding pulse output signal when the specified byte type constant is expressed in bits.	
6	T=Time	Specifies the time during which the pulse signal is output. The pulse signal is output during the specified time T.	Units: seconds Variable I/LI/I[]/LI[] can be used. (Units: 0.01 seconds) When the time is not specified, the pulse signal is output during 0.30 seconds.
7	ADJD	Based on the teaching position for the move instruction, specifies the distance to the signal output position. Performs the adjustment of distance as follows; specifying negative value to move the manipulator in the forward direction, and specifying positive value to move it in the backward direction. In case of specified "ADJD=0.0", the signal will be output when the manipulator passed the teaching position or comes to the closest approach.	No: -3276.8 to 3276.7 [mm] Variable B/I/D/LB/LI/LD can be used.



If specified adjustment distance from [ADJD=] is longer than the movement distance of target step, the signal will be output at the moment of the cursor moves to the move instruction. Unable to adjust the timing of signal output across the step.

No.	Tag	Explanation	Note
8	ADJT	Based on the teaching position for the move instruction, specifies the time to the signal output position. Performs the adjustment of time as follows; specifying negative value to move the manipulator in the forward direction, and specifying positive value to move it in the backward direction.	No: -327.68 to 327.67 [sec] Variable B/I/D/LB/LI/LD can be used.



If specified adjustment time from [ADJT=] is longer than the movement time of target step, the signal will be output at the moment of the cursor moves to the move instruction. Unable to adjust the timing of signal output across the step.

2 Setup of I/O Output Timing Control Function

2.1 Instruction of I/O Output Timing Control Function

2.1.5 Registration of +PULSE Instruction

Perform the registration of instructions while the cursor is in the address area of the job content display on the teach mode.

1. Select {JOB} under the main menu.
2. Select {JOB CONTENT}.
3. Move the cursor to desired move instruction of the teaching position to register the +PULSE instruction.



4. Press [SELECT].
 - Move instruction appears in the input buffer line.



2 Setup of I/O Output Timing Control Function

2.1 Instruction of I/O Output Timing Control Function

5. Changing additional item of the +PULSE instructions

- Move the cursor to the input buffer line, and then press the [SELECT] key to appear the detail edit display of the move instruction.

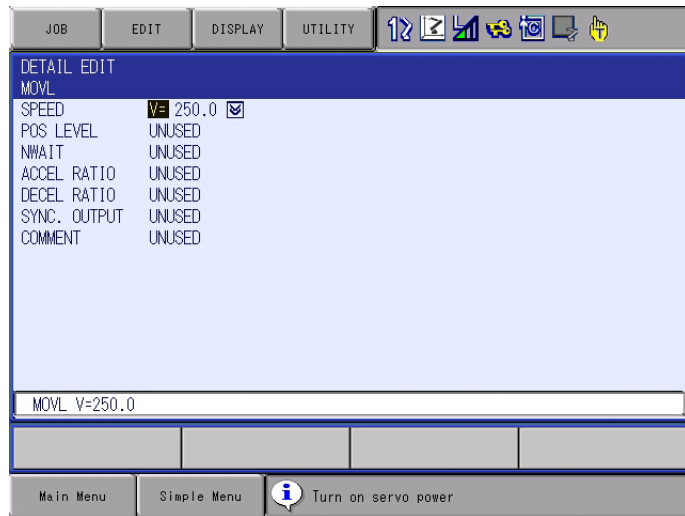

- Move the cursor to the [UNUSED] of [SYNC OUTPUT], and press [SELECT] key.

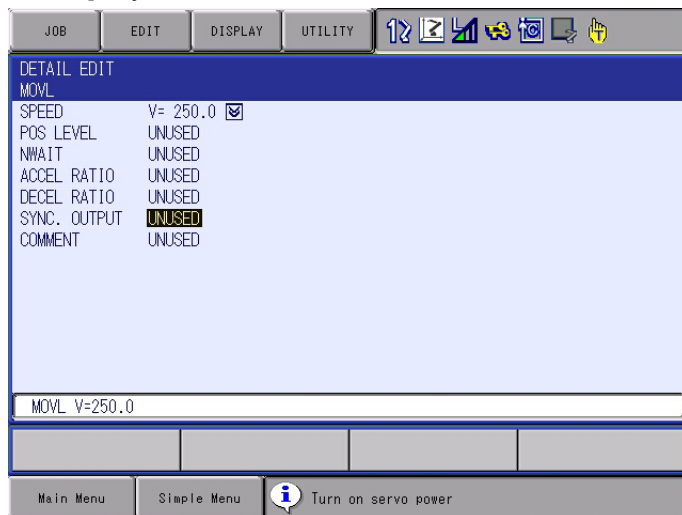

- When the selection dialog appears, select the [+PULSE] to display the detail edit display of the [+PULSE].

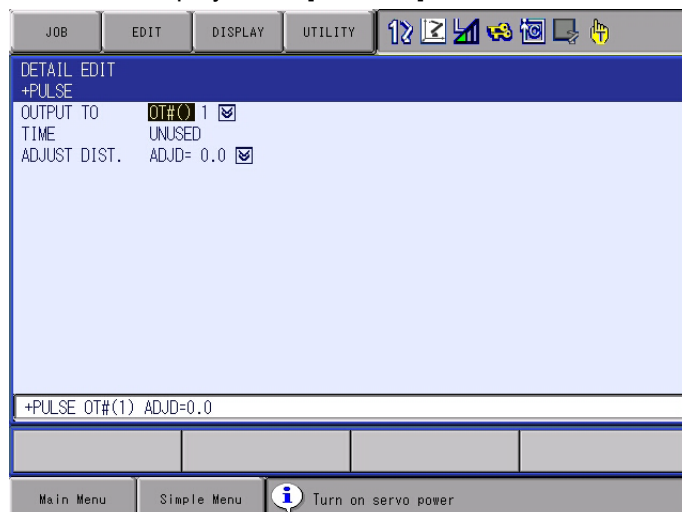

2 Setup of I/O Output Timing Control Function

2.1 Instruction of I/O Output Timing Control Function

- To change from [OUTPUT TO] to [OG#()] or [OGH#()], move the cursor to [OT#()] of [OUTPUT TO], and press [SELECT] key. The selection dialog will appear, then select [OG#()] or [OGH#()].

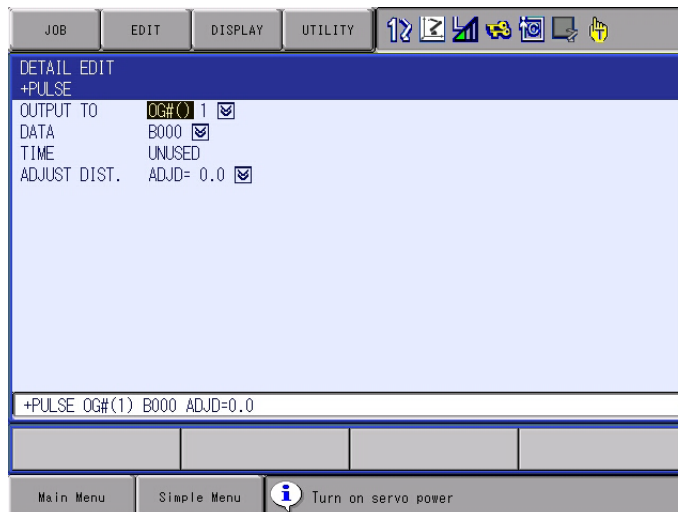

- To add [ADJUST TIME], move the cursor to [ADJ=], and press [SELECT] key. The selection dialog will appear, then select [ADJT=].

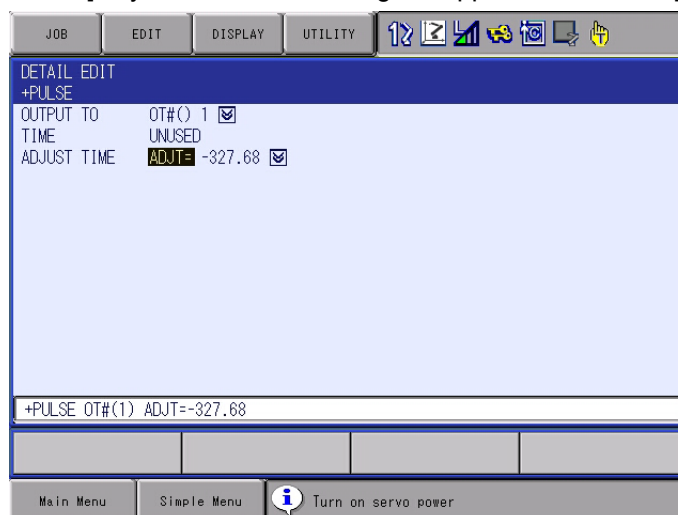

2 Setup of I/O Output Timing Control Function

2.1 Instruction of I/O Output Timing Control Function

- After adding or changing of additional items, and press [ENTER] key. The detail edit display of [+PULSE] will disappear, and the detail edit display of the move instruction will appear again.



- Press [ENTER] key, and the detail edit display of the move instruction will disappear. The job content display will appear.



6. Press [ENTER] key.

- The instruction in the input buffer line will be registered.

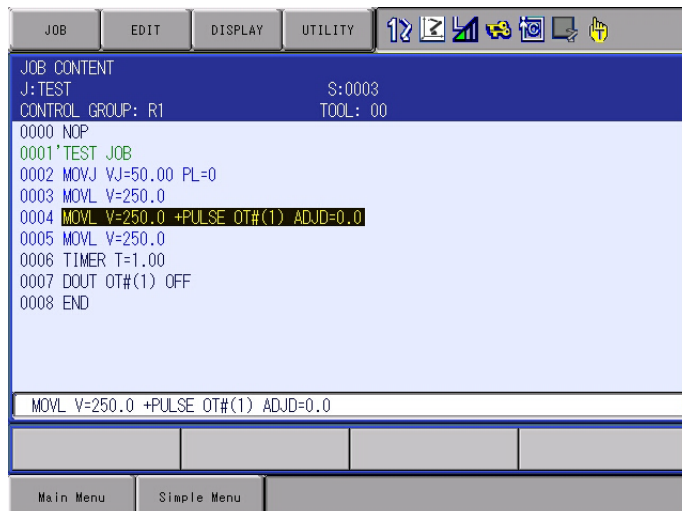

2 Setup of I/O Output Timing Control Function

2.2 Device Response Delay Time Compensate Parameter

2.2 Device Response Delay Time Compensate Parameter

The response time of devices such as valve and cylinder which are controlled from the synchronized signal output instruction (+DOUT/+PULSE) is known from catalog.

In these cases, the synchronized signal output instruction (+DOUT/+PULSE) will be able to output the signal in advance by setting the response time from these devices on to the parameter. It is unnecessary to consider delayed time from the devices during the adjustment operation of the adjustment distance or adjustment time. Therefore, it will reduce the adjustment man-hours.

JOB KIND	No	Semantics	Unit	Initial value
S4C	321	Compensating time of device response delay	0.01sec	0

2.3 Signal Output Control Parameter During the FWD Operation

At the teaching mode, when the move instruction with synchronized signal output instruction (+DOUT/+PULSE) in the FWD operation will be executed, it is able to specify the general output signal as [output] or [no output]. The parameter shown as follows. The initial value is set on as [0: output]. To output signal during the FWD operation, change the setting to [1: output].

JOB KIND	No	Semantics	Unit	Initial value
S4C	247	+DOUT/+PULSE during the FWD operation Execute specification 0: No output 1: Output	-	0

2.4 Notes

- The synchronized signal output instruction (+DOUT/+PULSE) is added to the move instruction of the first line. Thus, the control group which is monitored at the setting position as [adjustment distance] or [adjustment time] will be a specified robot in the first line.
- When the synchronized signal output instruction will be added to the joint move instruction, adjustment distance at specified at ADJD will be the straight line between the previous step teaching position and the current step teaching position added with synchronized signal output instruction.
- When the move instruction with the synchronized signal output instruction will operate by the BACK operation, the signal would not be output.
- The signal may be output in the different position from the specified distance when the synchronized signal output instruction (+DOUT/+PULSE) is used at the distance (ADJD) in the operation locus which the controlled point of the manipulator will be operated reciprocating/helical motion in the short pitch.

2 Setup of I/O Output Timing Control Function

2.4 Notes

- If the synchronized signal output instruction (+DOUT/+PULSE) is not followed by any move instructions when the [adjustment distance] for the back ward direction is specified to the instruction, the signal output is performed at the teaching position of a move instruction with the synchronized signal output instruction (+DOUT/+PULSE).
- If a conditional branch instruction such as CALL IF instruction is taught before the next move instruction when the [adjustment distance] for the back ward direction is specified to the instruction, the signal output is performed at the teaching position of a move instruction with the synchronized signal output instruction (+DOUT/+PULSE).

2 Setup of I/O Output Timing Control Function
 2.5 The Examples of the I/O Output Timing Specifying Function

2.5 The Examples of the I/O Output Timing Specifying Function

■ Specifying distance

In the case of setting [5] in to the parameter [S4C321: device response delay time]

- Forward direction

```
STEP  INSTRUCTION
      NOP
001   MOVJ
002   MOVL +DOUT #OT(1) ON ADJD=-10.0
      :
003   MOVL
      :
      END
```

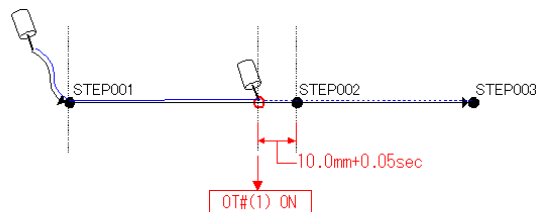

```
STEP  INSTRUCTION
      NOP
001   MOVJ
002   MOVL +DOUT #OT(1) ON ADJD=-1.0
      :
003   MOVL
      :
      END
```

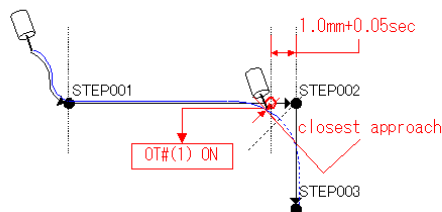

- Backward direction

```
STEP  INSTRUCTION
      NOP
001   MOVJ
002   MOVL +DOUT #OT(1) ON ADJD=10.0
      :
003   MOVL
      :
      END
```

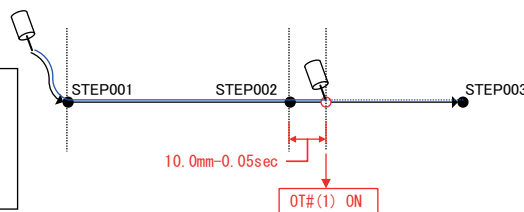

```
STEP  INSTRUCTION
      NOP
001   MOVJ
002   MOVL +DOUT #OT(1) ON ADJD=1.0
      :
003   MOVL
      :
      END
```

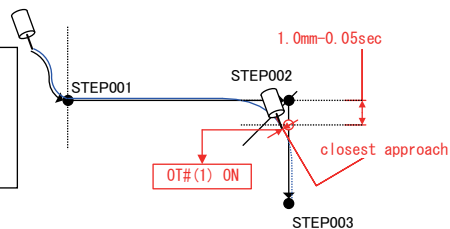

2 Setup of I/O Output Timing Control Function
 2.5 The Examples of the I/O Output Timing Specifying Function

■ Specifying time

In the case of setting [5] in to the parameter [S4C321: device response delay time]

- Forward direction

STEP	INSTRUCTION
	NOP
001	MOVJ
002	MOVL +DOUT #OT(1) ON ADJT=-1.00
003	MOVL
	:
	END

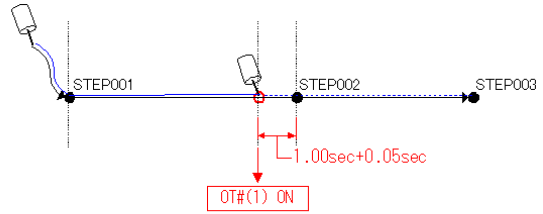

STEP	INSTRUCTION
	NOP
001	MOVJ
002	MOVL +DOUT #OT(1) ON ADJT=-1.00
003	MOVL
	:
	END

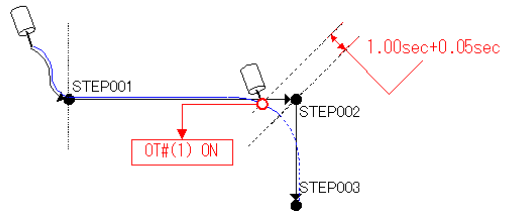

- Backward direction

STEP	INSTRUCTION
	NOP
001	MOVJ
002	MOVL +DOUT #OT(1) ON ADJT=1.00
003	MOVL
	:
	END

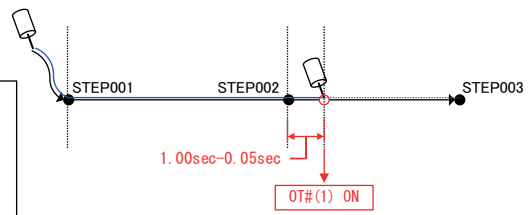

STEP	INSTRUCTION
	NOP
001	MOVJ
002	MOVL +DOUT #OT(1) ON ADJT=1.00
003	MOVL
	:
	END

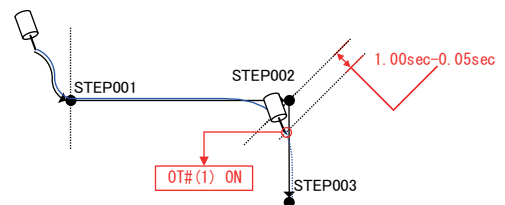

YRC1000 OPTIONS INSTRUCTIONS

FOR I/O OUTPUT TIMING CONTROL FUNCTION

HEAD OFFICE

2-1 Kurosakishi-roishi, Yahatanishi-ku, Kitakyushu 806-0004, Japan
Phone +81-93-645-7703 Fax +81-93-645-7802

YASKAWA America Inc. (Motoman Robotics Division)
100 Automation Way, Miamisburg, OH 45342, U.S.A.
Phone +1-937-847-6200 Fax +1-937-847-6277

YASKAWA Europe GmbH (Robotics Division)
Yaskawastrasse 1, 85391 Allershausen, Germany
Phone +49-8166-90-100 Fax +49-8166-90-103

YASKAWA Nordic AB
Verkstadsgatan 2, Box 504, SE-385 25 Torsås, Sweden
Phone +46-480-417-800 Fax +46-486-414-10

YASKAWA Electric (China) Co., Ltd.
22F, One Corporate Avenue, No.222, Hubin Road, Huangpu District, Shanghai 200021, China
Phone +86-21-5385-2200 Fax +86-21-5385-3299

YASKAWA SHOUGANG ROBOT Co. Ltd.
No7 Yongchang North Road, Beijing E&T Development Area, China 100176
Phone +86-10-6788-2858 Fax +86-10-6788-2878

YASKAWA India Private Ltd. (Robotics Division)
#426, Udyog Vihar, Phase- IV, Gurgaon, Haryana, India
Phone +91-124-475-8500 Fax +91-124-475-8542

YASKAWA Electric Korea Corporation
35F, Three IFC, 10 Gukjegeumyung-ro, Yeongdeungpo-gu, Seoul, Korea 07326
Phone +82-2-784-7844 Fax +82-2-784-8495

YASKAWA Electric Taiwan Corporation
12F, No.207, Sec. 3, Beishin Rd., Shindian District, New Taipei City 23143, Taiwan
Phone +886-2-8913-1333 Fax +886-2-8913-1513

YASKAWA Electric (Singapore) PTE Ltd.
151 Lorong Chuan, #04-02A, New Tech Park, Singapore 556741
Phone +65-6282-3003 Fax +65-6289-3003

YASKAWA Electric (Thailand) Co., Ltd.
59,1st-5th Floor, Flourish Building, Soi Ratchadapisek 18,Ratchadapisek Road,
Huaykwang, Bangkok 10310, THAILAND
Phone +66-2-017-0099 Fax +66-2-017-0199

PT. YASKAWA Electric Indonesia
Secure Building-Gedung B Lantai Dasar & Lantai 1 Jl. Raya Protokol Halim Perdanakusuma,
Jakarta 13610, Indonesia
Phone +62-21-2982-6470 Fax +62-21-2982-6741

Specifications are subject to change without notice
for ongoing product modifications and improvements.

YASKAWA

YASKAWA ELECTRIC CORPORATION

© Printed in Japan September 2016 16-09

MANUAL NO.

HW1483368