

FS100 OPTIONS INSTRUCTIONS

FOR CONCURRENT I/O

-
- Upon receipt of the product and prior to initial operation, read these instructions thoroughly, and retain for future reference.
 - This instruction is applicable to both FS100 and FS100L controllers.
-

MOTOMAN INSTRUCTIONS

(FOR SMALL -SIZED MANIPULATORS)

MOTOMAN-□□□ INSTRUCTIONS

FS100 INSTRUCTIONS

FS100 OPERATOR'S MANUAL

FS100 MAINTENANCE MANUAL

(FOR LARGE AND MEDIUM-SIZED MANIPULATORS)

MOTOMAN-□□□ INSTRUCTIONS

FS100L INSTRUCTIONS

FS100 OPERATOR'S MANUAL

FS100L MAINTENANCE MANUAL

The FS100 OPERATOR'S MANUAL above is applicable to both FS100 and FS100L controllers.

Part Number: 164103-1CD

Revision: 2



MANDATORY

- This manual explains the Concurrent I/O of the FS100 system. Read this manual carefully and be sure to understand its contents before handling the FS100.
- General items related to safety are listed in Chapter 1: Safety of the FS100 Instructions. To ensure correct and safe operation, carefully read the FS100 Instructions before reading this manual.



CAUTION

- Some drawings in this manual are shown with the protective covers or shields removed for clarity. Be sure all covers and shields are replaced before operating this product.
- The drawings and photos in this manual are representative examples and differences may exist between them and the delivered product.
- YASKAWA may modify this model without notice when necessary due to product improvements, modifications, or changes in specifications. If such modification is made, the manual number will also be revised.
- If your copy of the manual is damaged or lost, contact a YASKAWA representative to order a new copy. The representatives are listed on the back cover. Be sure to tell the representative the manual number listed on the front cover.
- YASKAWA is not responsible for incidents arising from unauthorized modification of its products. Unauthorized modification voids your product's warranty.

NOTE

This instruction manual is applicable to both FS100 (a controller for small-sized manipulators) and FS100L (a controller for large and medium-sized manipulators).

- The description of "FS100" refers to both "FS100" and "FS100L" in this manual unless otherwise specified.

Notes for Safe Operation

Read this manual carefully before installation, operation, maintenance, or inspection of the FS100.

In this manual, the Notes for Safe Operation are classified as “WARNING”, “CAUTION”, “MANDATORY”, or “PROHIBITED”.



WARNING

Indicates a potentially hazardous situation which, if not avoided, could result in death or serious injury to personnel.



CAUTION

Indicates a potentially hazardous situation which, if not avoided, could result in minor or moderate injury to personnel and damage to equipment. It may also be used to alert against unsafe practices.



MANDATORY

Always be sure to follow explicitly the items listed under this heading.



PROHIBITED

Must never be performed.

Even items described as “CAUTION” may result in a serious accident in some situations.

At any rate, be sure to follow these important items.



To ensure safe and efficient operation at all times, be sure to follow all instructions, even if not designated as “CAUTION” and “WARNING”.



WARNING

- Before operating the manipulator, check that servo power is turned off when the emergency stop button on the programming pendant is pressed.
When the servo power is turned off, the SERVO ON LED on the programming pendant is turned off.

Injury or damage to machinery may result if the emergency stop circuit cannot stop the manipulator during an emergency. The manipulator should not be used if the emergency stop button does not function.

Fig. : Emergency Stop Button



- In the case of not using the programming pendant, be sure to supply the emergency stop button on the equipment. Then before operating the manipulator, check to be sure that the servo power is turned OFF by pressing the emergency stop button.
Connect the external emergency stop button to the 5-6 pin and 16-17 pin of the robot system signal connector (CN2).
- Upon shipment of the FS100, this signal is connected by a jumper cable in the dummy connector. To use the signal, make sure to prepare a new connector, and then input it.

If the signal is input with the jumper cable connected, it does not function, which may result in personal injury or equipment damage.

- Once the emergency stop button is released, clear the cell of all items which could interfere with the operation of the manipulator.
Then turn the servo power ON.

Injury may result from unintentional or unexpected manipulator motion.

Fig. : Release of Emergency Stop



- Observe the following precautions when performing teaching operations within the manipulator's operating range:
 - View the manipulator from the front whenever possible.
 - Always follow the predetermined operating procedure.
 - Keep in mind the emergency response measures against the manipulator's unexpected motion toward you.
 - Ensure that you have a safe place to retreat in case of emergency.

Improper or unintended manipulator operation may result in injury.



WARNING

- Confirm that no person is present in the manipulator's operating range and that you are in a safe location before:
 - Turning on the power for the FS100.
 - Moving the manipulator with the programming pendant.
 - Running the system in the check mode.
 - Performing automatic operations.

Injury may result if anyone enters the manipulator's operating range during operation. Always press an emergency stop button immediately if there is a problem.

The emergency stop button is located on the right of the programming pendant.



CAUTION

- Perform the following inspection procedures prior to conducting manipulator teaching. If a problem is found, correct it and take all other necessary actions immediately.
 - Check for problems in manipulator movement.
 - Check for damage to insulation and sheathing of external wires.
- Return the programming pendant to a safe place after use.

If the programming pendant is inadvertently left on the manipulator, on a fixture, or on the floor, the manipulator or a tool may collide with the programming pendant during manipulator movement, which may result in personal injury or equipment damage.

- Read and understand the Explanation of the Warning Labels before operating the manipulator.

Definition of Terms Used Often in This Manual



The MOTOMAN is the YASKAWA industrial robot product.

The MOTOMAN usually consists of the manipulator, the FS100 controller, manipulator cables, the FS100 programming pendant (optional), and the FS100 programming pendant dummy connector (optional).

In this manual, the equipment is designated as follows:

Equipment	Manual Designation
FS100 controller	FS100
FS100 programming pendant	Programming pendant
Cable between the manipulator and the controller	Manipulator Cable
FS100 programming pendant dummy connector	Programming pendant dummy connector

Descriptions of the programming pendant keys, buttons, displays and keyboard of the PC are shown as follows:

Equipment		Manual Designation
Programming Pendant	Character Keys	The keys which have characters printed on them are denoted with []. e.g. [ENTER]
	Symbol Keys	The keys which have a symbol printed on them are not denoted with [] but depicted with a small picture. e.g. PAGE key  The cursor key is an exception, and a picture is not shown.
	Axis Keys Numeric Keys	“Axis keys” and “Numeric keys” are generic names for the keys for axis operation and number input.
	Keys Pressed Simultaneously	When two keys are to be pressed simultaneously, the keys are shown with a “+” sign between them. e.g. SHIFT key  + COORD key 
	Mode Key	Three kinds of modes that can be selected by the mode key are denoted as follows: REMOTE, PLAY, or TEACH
	Button	Three buttons on the upper side of the programming pendant are denoted as follows: HOLD button START button EMERGENCY STOP button
	Displays	The menu displayed in the programming pendant is denoted with { }. e.g. {JOB}
PC Keyboard		The name of the key is denoted. e.g. Ctrl key on the keyboard

Description of the Operation Procedure

In the explanation of the operation procedure, the expression “Select ●●●” means that the cursor is moved to the object item and the SELECT key is pressed, or that the item is directly selected by touching the screen.

Registered Trademark

In this manual, names of companies, corporations, or products are trademarks, registered trademarks, or brand names for each company or corporation. The indications of (R) and TM are omitted.

1	Concurrent I/O	1-1
1.1	Features of Concurrent I/O	1-1
1.2	Configuration and Specifications of Concurrent I/O	1-2
2	Classification of I/O Signals	2-1
2.1	I/O Signals	2-2
2.1.1	Meaning of Number	2-2
2.2	Register	2-4
3	Configuration of I/O Signals	3-1
4	System I/O Signals	4-1
4.1	Common System Input Signals	4-1
4.2	System Input Signals for Operations	4-14
4.2.1	Device 1	4-14
4.2.2	Device 2	4-15
4.3	Description of System Input Signals	4-16
4.3.1	Alarm and Message Display	4-16
4.3.2	Mode and Cycle Selection and Master Job Call	4-19
4.3.3	Start and Stop	4-21
4.3.4	Operation Command	4-22
4.3.5	Independent Control Signals (Optional)	4-25
4.3.6	Signals for Operations	4-27
4.4	Common System Output Signals	4-28
4.5	System Output Signals for Operations	4-45
4.5.1	Device 1	4-45
4.5.2	Device 2	4-46
4.6	Description of System Output Signals	4-47
4.6.1	Alarm and Message Display	4-47
4.6.2	Mode and Cycle Selection and Particular Operation Setting	4-48
4.6.3	Start and Stop	4-49
4.6.4	Interference Signals	4-52
4.6.5	Arithmetic Instruction Signals	4-52
4.6.6	Independent Control Signals (Optional)	4-52
4.6.7	Signals for Servo Float Function (Optional)	4-54
4.6.8	Signals for Operations	4-54

5	Auxiliary Relay Signals.....	5-1
6	Internal Control Status Signals.....	6-1
6.1	List of Internal Control Status Signals.....	6-1
6.1.1	Description of Internal Control Status Signals (Monitor).....	6-5
7	Pseudo Input Signals.....	7-1
7.1	Description of Pseudo Input Signals.....	7-1
8	Network I/O Signals.....	8-1
9	Interface Panel Signals.....	9-1
10	I/O Signals Except Concurrent I/O.....	10-1
10.1	Description.....	10-1
11	Registers.....	11-1
11.1	Common Registers.....	11-1
11.1.1	Common User Registers.....	11-1
11.1.2	Common System Registers.....	11-3
11.2	Registers for Operations.....	11-4
12	Standard Ladder Programs.....	12-1
12.1	List of Usable Instructions.....	12-1
12.2	Description of Concurrent I/O Instructions.....	12-7
12.2.1	STR Instruction.....	12-7
12.2.2	STR-NOT Instruction.....	12-7
12.2.3	AND Instruction.....	12-8
12.2.4	AND-NOT Instruction.....	12-8
12.2.5	OR Instruction.....	12-8
12.2.6	OR-NOT Instruction.....	12-9
12.2.7	AND-STR Instruction.....	12-9
12.2.8	OR-STR Instruction.....	12-9
12.2.9	OUT Instruction.....	12-10
12.2.10	PART Instruction.....	12-10
12.2.11	END Instruction.....	12-11
12.2.12	TMR Instruction.....	12-12
12.2.13	CNT Instruction.....	12-13
12.2.14	GSTR Instruction and GOUT Instruction.....	12-14

12.2.15	PLS Instruction	12-15
12.2.16	PLF Instruction	12-16
12.2.17	ADD Instruction	12-17
12.2.18	SUB Instruction	12-18
12.2.19	MUL Instruction	12-19
12.2.20	DIV Instruction	12-20
12.2.21	MOD Instruction	12-21
12.2.22	BIN Instruction	12-22
12.2.23	BCD Instruction	12-23
12.2.24	MOV Instruction	12-24
12.2.25	WAND Instruction	12-25
12.2.26	WOR Instruction	12-26
12.2.27	WXOR Instruction	12-27
12.2.28	WNOT Instruction	12-28
12.2.29	SHL Instruction	12-29
12.2.30	SHR Instruction	12-30
12.2.31	ROL Instruction	12-31
12.2.32	ROR Instruction	12-32
12.2.33	MLTMR Instruction	12-33
12.3	Arithmetic Flag	12-34
12.3.1	Flag Type	12-34
12.3.2	Flag Transition Under Scanning	12-34
12.4	Default Setting	12-35
12.4.1	List of Ladder Programs	12-35
12.4.2	I/O Alarms	12-55
12.4.3	I/O Messages	12-56
13	How to Monitor Signals	13-1
13.1	Monitoring I/O Signals	13-1
13.1.1	I/O Window	13-1
13.2	I/O Status Window	13-3
13.2.1	Registering Signal Name	13-4
13.2.2	Changing Signal Status from UNIVERSAL OUTPUT Window	13-5

13.2.3	Changing Signal Status from UNIVERSAL INPUT Window	13-6
13.2.3.1	Batch Selection of SIM	13-10
13.2.3.2	Batch Cancellation of SIM	13-11
13.2.3.3	IO Simulation Search.....	13-12
13.2.4	Changing Signal Status from EXTERNAL OUTPUT Window	13-15
13.2.4.1	Batch Selection of SIM	13-18
13.2.4.2	Batch Cancellation of SIM	13-19
13.2.4.3	IO Simulation Search.....	13-20
13.2.5	Changing Signal Status from EXTERNAL INPUT Window	13-23
13.2.5.1	Batch Selection of SIM	13-26
13.2.5.2	Batch Cancellation of SIM	13-27
13.2.5.3	IO Simulation Search.....	13-28
13.3	Pseudo Input Signal Window	13-31
13.3.1	Checking Pseudo Input Signal Status	13-31
13.3.2	Changing Pseudo Input Signal Status	13-32
13.3.3	Registering Signal Name	13-33
13.4	Register Window	13-35
13.4.1	Checking Register	13-35
13.4.2	Setting Register	13-36
13.4.3	Registering Signal Name	13-38
13.5	Analog Output Window	13-40
13.5.1	Operating Procedure	13-41
13.6	I/O Messages and I/O Alarms.....	13-42
13.6.1	Displaying User Section.....	13-42
13.6.2	Registering User Section	13-43
13.7	Ladder Program Window	13-44
13.8	IO Simulation List Window	13-47
14	Editing Ladder Programs	14-1
14.1	Flow of Data by Ladder Programs	14-1
14.2	Editing by Mnemonic and Ladder Editor Program	14-2
14.3	Mnemonic Editing Window.....	14-3
14.3.1	Basic Operation	14-3

14.3.2	Editing Operation.....	14-4
14.3.2.1	Inserting Instruction.....	14-4
14.3.2.2	Changing Instruction.....	14-7
14.3.2.3	Deleting Instruction.....	14-9
14.3.2.4	Editing Operand.....	14-9
14.3.2.5	Cancelling Editing.....	14-11
14.3.3	Compile.....	14-12
14.3.4	Search.....	14-13
14.3.4.1	Top Line and End Line.....	14-14
14.3.4.2	Search for Line No. and Block No.....	14-14
14.3.4.3	Search for Relay No. and Register No.....	14-15
14.4	Loading Ladder Program with Different System Section.....	14-16
15	Clearing Signal.....	15-1
15.1	Clearing User Output Signal.....	15-1
15.1.1	Clearing Signal when Powering ON.....	15-1
15.1.2	Clearing Signal when Switching Between Teach and Play Mode.....	15-2
15.2	Clearing Interface Panel Signal.....	15-4
15.2.1	Clearing Signal when Powering ON.....	15-4
15.3	Clearing Auxiliary Relay Signal.....	15-5
15.3.1	Clearing Signal when Powering ON.....	15-5
15.4	Clearing User Register.....	15-9
15.4.1	Clearing Register when Powering ON.....	15-9

1 Concurrent I/O

Concurrent I/O control is an I/O control function that processes controls related to the FS100 I/O independently of the manipulator operation (in parallel with manipulator operation).

1.1 Features of Concurrent I/O

- Terminals and connectors to which I/O signals are connected can be used effectively.
 - Terminals and connectors are provided for connecting I/O signals. Although the number of connections are limited, the terminals can be used effectively because only the necessary signals can be selected and connected to the desired terminal.

- Instructions related to the I/O (Robot Language: INFORM III) can be simplified for smooth manipulator operation.
 - Fixed procedures relative to the I/O can be registered as independent ladder programs, thus enabling simplification of I/O instructions of the job (operation program) and reducing interruptions.

- Reserved signals can be accepted while the manipulator is operating.
 - Reserved signals can be accepted during operation since manipulator operation processing and I/O processing can be executed at the same time.

1.2 Configuration and Specifications of Concurrent I/O

The Concurrent I/O is configured with the following two blocks.

Fig. 1-1: Configuration of Concurrent I/O Ladder Program

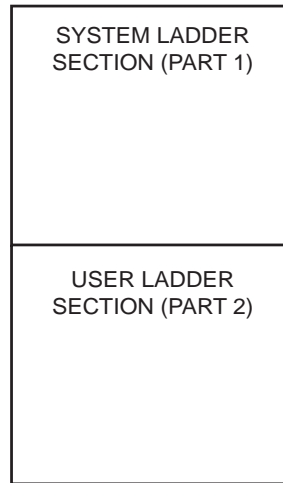

System Ladder
Section

The standard ladder selected for the user's system is factory-set.

For more information, see *Chapter 12 "Standard Ladder Programs"*.

The ladder program cannot be edited.

User Ladder
Section

Specification of signal connections and interface signal with system ladder are factory-set.

The ladder program can be edited including these signals.

FS100	1	Concurrent I/O
	1.2	Configuration and Specifications of Concurrent I/O

Table 1-1: Concurrent I/O Specifications

Item	Contents
Control Method	Scan control by stored program
Programming	Relay ladder program symbology
Scan Time	1 msec
Memory Capacity	1500 steps
Number of Instructions	33 types
General Input Port	1024 points (Concurrent I/O → Manipulator Control Section)
General Output Port	1024 points (Concurrent I/O ← Manipulator Control Section)
Specific Input Port	1280 points including unspecified signals (Concurrent I/O → Manipulator Control Section)
Specific Output Port	1600 points including unspecified signals (Concurrent I/O ← Manipulator Control Section)
Hardware Status Signal Points	512 points (Concurrent I/O → Manipulator Control Section)
Auxiliary Relays	7992 points
External Inputs	1024 points
External Outputs	1024 points
Register (Numeric Data)	General Register 560 points (0-65535) System Register 360 points (0-65535) Analog output register 40 points (0-65535) Analog input register 40 points (0-65535)
Pseudo Input Signal Points	160 points (Concurrent I/O ← System Parameter)
Power Failure Protective Function	Ladder Program (Battery Back-Up) Output status is reset.
Diagnostic Functions	Error Detection of CPU, system program and ladder programs. Ladder programming error detection as follows: Double Use of Output Relay No END Instruction Circuit Error Format Error Exceeded Program Capacity
Monitor Function	Monitor each signal status in concurrent I/O on CRT window.

NOTE Although the scan time is as mentioned above, keep ON or OFF status of the inputting signal sufficiently longer than the scan time so that the signal is correctly recognized.

2 Classification of I/O Signals

Table 2-1: Classification of I/O signals

Logic Name	Classification	Description	Range
0 xxxx	General Input	Referenced with input instruction of the job	00010 - 01287 (1024 signals)
1 xxxx	General Output	Referenced with output instruction of the job	10010 - 11287 (1024 signals)
2 xxxx	External Input	Signal No. corresponding to the input terminal	20010 - 21287 (1024 signals)
3 xxxx	External Output	Signal No. corresponding to the output terminal	30010 - 31287 (1024 signals)
4 xxxx	Specific Input	Signal to change the operating condition of the robot	40010 - 41607 (1280 signals)
5 xxxx	Specific Output	Signal notifying the operating condition of the robot	50010 - 52007 (1600 signals)
6 xxxx	Interface Panel Input	Signal notifying the operating condition of the interface panel	60010 - 60647 (512 signals)
7 xxxx	Auxiliary Relay	Auxiliary relay in the concurrent I/O	70010 - 79997 (7992 signals)
80 xxx	Control Status	Monitoring of the hardware signal status of the robot control section	80010 - 80647 (512 signals)
82 xxx	Pseudo Input	Pseudo input relay reading from the system parameter	82010 - 82207 (160 signals)
25 xxx	Network Input	Input signal from the network device	25010 - 26287 (1024 signals)
35 xxx	Network Output	Input signal to the network device	35010 - 36287 (1024 signals)
M xxx	Register	1 word data (16 bits) General Register: M000 - M559 Analog Output Register: M560 - M599 Analog Input Register: M600 - M639 System Register: M640 - M999	M000 - M999 (1000 signals)

2.1 I/O Signals

2.1.1 Meaning of Number

The I/O processing part and the manipulator operation processing part are connected by “Logical I/O”. However, for the function, they are separated as a quite independent function. How to handle each signal is also different from the manipulator operation processing part.

In ladder programming, to specify each signal unitedly, the number is set to as follows. “Relay number” is specified by the numerical value of five digits. This numerical value is composed of the following three information.

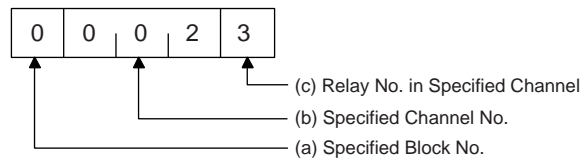

1. Specified Block Number: This is divided into the following block.

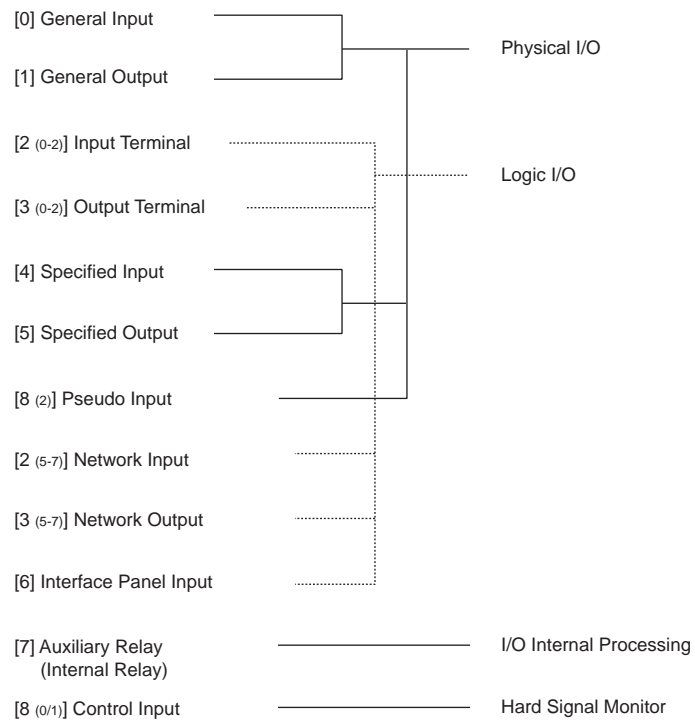

2. Specified Channel Number: Eight signals are defined as one channel.

– [001] Last eight signals



[nnn] Last eight signals

– Refer to the following table for channel numbers.

3. Relay Number in Specified Channel:

One of eight signals is specified by numerical value (0-7).

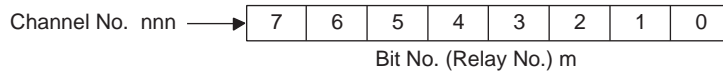

- As for each block, a minimum digit is specified by the numerical value to 0-7 for a relay number as understood from the table. In a word, it is a serial number which omits 8 and 9.
- Moreover, the first relay number of each block starts from xxx10 because channel number enters between digits of 10, 100, and 1000.

The relay number will be specified by the numerical value of the fifth digit in the frame.

Block Number: 0

Relay Number: 0 nnn m

nn: Channel 01 →	00019	00018	00017	00016	00015	00014	00013	00012	00011	00010
Channel 02 →	00029	00028	00027	00026	00025	00024	00023	00022	00021	00020
Channel 03 →	00039	00038	00037	00036	00035	00034	00033	00032	00031	00030
Channel 04 →	00049	00048	00047	00046	00045	00044	00043	00042	00041	00040
Channel 05 →	00059	00058	00057	00056	00055	00054	00053	00052	00051	00050
Channel 06 →	00069	00068	00067	00066	00065	00064	00063	00062	00061	00060

↑ No relay corresponds to these numbers.
 (These numbers cannot be used.)



NOTE

The relay is occasionally treated by the units (8 bits) of the byte (channel) or the units (16 bits) of the word.

2.2 Register

The register is data of each every word (16 bits).

General register (M000 - M559) and analog output register (M560 - M599) are readable and writable.

System register (M640 - M999) and analog input register (M600 - M639) are readable only, and the data is set by the system.



The register is treated by the unit of one word (16 bits).

Therefore, it is not possible to handle it by the bit specification instruction (STR, AND, OR, and OUT, etc.) and the PLS instructions, etc.

1. General Register

This is composed of one word (16 bits).

Bit	15	14	13	12	11	10	9	8	7	6	5	4	3	2	1	0
M000																
M001																
:																
M559																

2. System Register

This is composed of one word (16 bits).

Bit	15	14	13	12	11	10	9	8	7	6	5	4	3	2	1	0
M640																
M641																
:																
M999																

3. Analog Output Register

This is composed of one word (16 bits). The analog output registers (M560 - M599) correspond to the analog outputs 1 to 40. Since an analog output board with different digital resolution (D/A circuit) is used in common with the analog output register, the data below the resolution is cut off at output.

Analog output	Bit	15	14	13	12	11	10	9	8	7	6	5	4	3	2	1	0
AOUT01	M560																
AOUT02	M561																
:	:																
AOUT40	M599																

4. Resolution and Valid Data

- 8-bit resolution : Bit 8 to Bit 15 are valid data.
- 12-bit resolution: Bit 4 to Bit 15 are valid data.
- 16-bit resolution: Bit 0 to Bit 15 are valid data.

Resolution	Bit	15	14	13	12	11	10	9	8	7	6	5	4	3	2	1	0
8-bit																	
12-bit																	
16-bit																	

Regardless of the resolution, the register value per 1 V is:

$$1 (V) = 32767 (7fffH) / 10 (V) \approx 3276 (cccH)$$

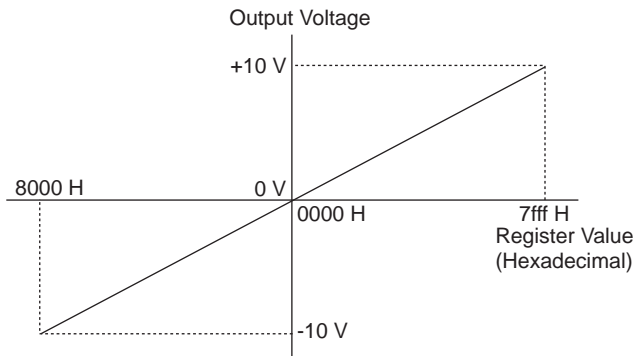

Analog output board (JANCD-YEW01-□, JANCD-XEW01-□, JANCD-XEW02) uses a 12-bit resolution D/A circuit.

5. Analog Input Register

This is composed of one word (16 bits). The analog input registers (M600 - M639) correspond to the analog inputs 1 to 40.

Analog input	Bit	15	14	13	12	11	10	9	8	7	6	5	4	3	2	1	0
AIN01	M600																
AIN02	M601																
:	:																
AIN40	M639																

The register value per 1 V is:

$$1 (V) = 32767 (7fffH) / 10 (V) \approx 3276 (cccH)$$

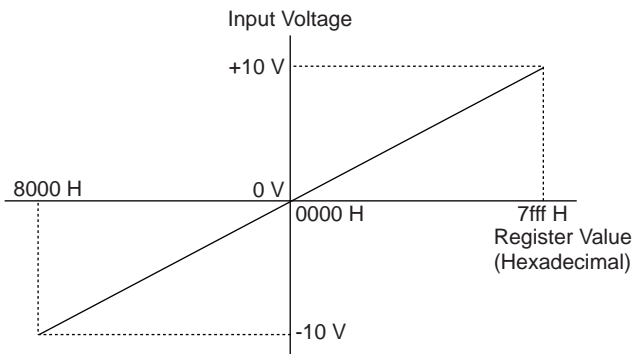

6. Numeric Data

- Binary number is the one that the numeric data was expressed by 1 (ON) and 0 (OFF).
- Internal data of a usual computer is expressed by the binary number.
- On the other hand, BCD (Binary Code Decimal) makes one digit of the decimal number by using four bits of the binary number, that is, four digits, combines these, and shows the decimal number.
- The equipment connected with FS100 occasionally uses BCD as an input and a output signal. When transferring the data between these, it is necessary to convert BCD into the binary number when FS100 receives the data, and it is necessary to convert the binary number into BCD when outputting the data to the equipment.
- It is possible to convert the data by BIN and the BCD instruction in the concurrent I/O function.

Table 2-2: Binary Number

Bit	15	14	13	12	11	10	9	8	7	6	5	4	3	2	1	0
	2^{15}	2^{14}	2^{13}	2^{12}	2^{11}	2^{10}	2^9	2^8	2^7	2^6	2^5	2^4	2^3	2^2	2^1	2^0

Table 2-3: BCD

	←Digit of 1000→				←Digit of 100→				←Digit of 10→				←Digit of 1→			
Bit	15	14	13	12	11	10	9	8	7	6	5	4	3	2	1	0
	2^3	2^2	2^1	2^0	2^3	2^2	2^1	2^0	2^3	2^2	2^1	2^0	2^3	2^2	2^1	2^0

Table 2-4: Binary Number and BCD Expression of Decimal Number

Decimal Number	Binary	BCD
1	0000 0000 0000 0001	0000 0000 0000 0001
12	0000 0000 0000 1100	0000 0000 0001 0010
123	0000 0000 0111 1011	0000 0001 0010 0011
1234	0000 0100 1101 0010	0001 0010 0011 0100

3 Configuration of I/O Signals

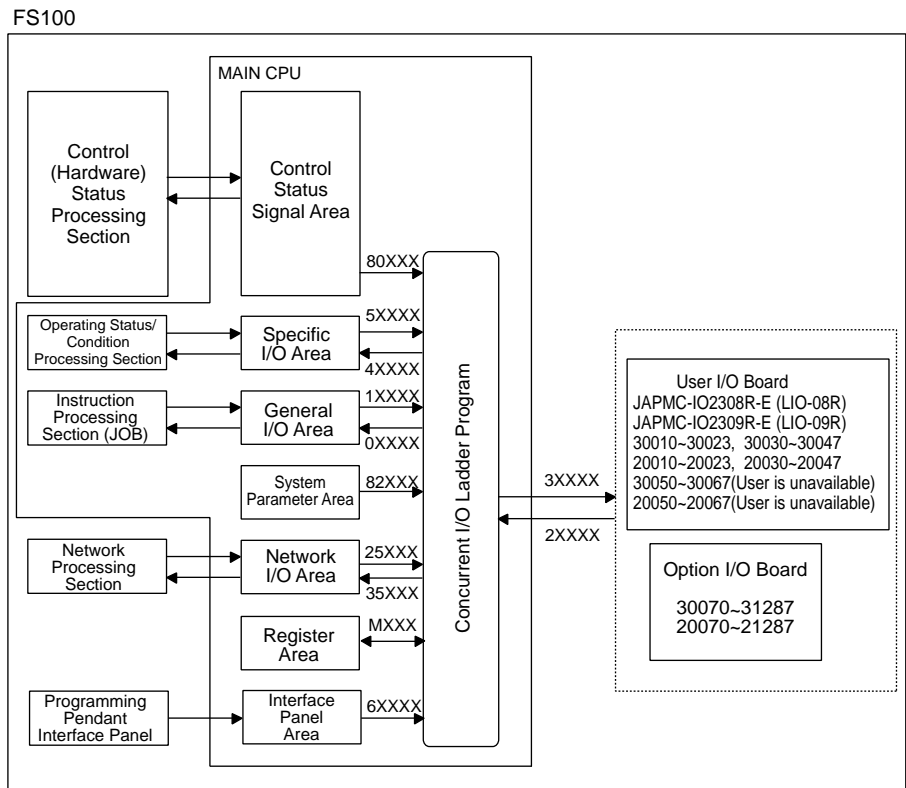

How to Monitor Signal Status

To monitor a signal, verify the signal status of the signal logic number in the I/O monitor window (refer to Section 13.1.1 “I/O Window” on page 13-1).

4 System I/O Signals

4.1 Common System Input Signals

40017	40016	40015	40014	40013	40012	40011	40010
SIN#008	SIN#007	SIN#006	SIN#005	SIN#004	SIN#003	SIN#002	SIN#001
	SPEED LIMIT		ALM/ERR RESET	USER MSG REQ	USER ALM REQ	SYSTEM MSG REQ	SYSTEM ALM REQ

40027	40026	40025	40024	40023	40022	40021	40020
SIN#016	SIN#015	SIN#014	SIN#013	SIN#012	SIN#011	SIN#010	SIN#009
		SUB5 ALM REQ	SUB4 ALM REQ	SUB3 ALM REQ	SUB2 ALM REQ	SUB1 ALM REQ	

40037	40036	40035	40034	40033	40032	40031	40030
SIN#024	SIN#023	SIN#022	SIN#021	SIN#020	SIN#019	SIN#018	SIN#017

40047	40046	40045	40044	40043	40042	40041	40040
SIN#032	SIN#031	SIN#030	SIN#029	SIN#028	SIN#027	SIN#026	SIN#025
	CHECK-RUN	EXT SERVO ON	EXT START		CMD REMOTE SEL	PLAY MODE SEL	TEACH MODE SEL

40057	40056	40055	40054	40053	40052	40051	40050
SIN#040	SIN#039	SIN#038	SIN#037	SIN#036	SIN#035	SIN#034	SIN#033
INHIBIT IO	INHIBIT PP/ PANEL		EXT SERVO OFF3		CONT CYCLE SEL	1-CYCLE SEL	STEP CYCLE SEL

40067	40066	40065	40064	40063	40062	40061	40060
SIN#048	SIN#047	SIN#046	SIN#045	SIN#044	SIN#043	SIN#042	SIN#041
EXT HOLD	EXT SERVO OFF2	EXT SERVO OFF1	EDIT LOCK	OT RELEASE REQ		SHOCK DTCT OFF	MACHINE- LOCK

40077	40076	40075	40074	40073	40072	40071	40070
SIN#056	SIN#055	SIN#054	SIN#053	SIN#052	SIN#051	SIN#050	SIN#049
		SUB5 MASTER CALL	SUB4 MASTER CALL	SUB3 MASTER CALL	SUB2 MASTER CALL	SUB1 MASTER CALL	MASTER JOB CALL

40087	40086	40085	40084	40083	40082	40081	40080
SIN#064	SIN#063	SIN#062	SIN#061	SIN#060	SIN#059	SIN#058	SIN#057

40097	40096	40095	40094	40093	40092	40091	40090
SIN#072	SIN#071	SIN#070	SIN#069	SIN#068	SIN#067	SIN#066	SIN#065
						STEP BACK R2J	STEP BACK R1J

40107	40106	40105	40104	40103	40102	40101	40100
SIN#080	SIN#079	SIN#078	SIN#077	SIN#076	SIN#075	SIN#074	SIN#073

40117	40116	40115	40114	40113	40112	40111	40110
SIN#088	SIN#087	SIN#086	SIN#085	SIN#084	SIN#083	SIN#082	SIN#081

40127	40126	40125	40124	40123	40122	40121	40120
SIN#096	SIN#095	SIN#094	SIN#093	SIN#092	SIN#091	SIN#090	SIN#089

40137	40136	40135	40134	40133	40132	40131	40130
SIN#104	SIN#103	SIN#102	SIN#101	SIN#100	SIN#099	SIN#098	SIN#097
						WAIT JOB SEQ R2J	WAIT JOB SEQ R1J

40147	40146	40145	40144	40143	40142	40141	40140
SIN#112	SIN#111	SIN#110	SIN#109	SIN#108	SIN#107	SIN#106	SIN#105
					WAIT JOB SEQ S3J	WAIT JOB SEQ S2J	WAIT JOB SEQ S1J

40157	40156	40155	40154	40153	40152	40151	40150
SIN#120	SIN#119	SIN#118	SIN#117	SIN#116	SIN#115	SIN#114	SIN#113

40167	40166	40165	40164	40163	40162	40161	40160
SIN#128	SIN#127	SIN#126	SIN#125	SIN#124	SIN#123	SIN#122	SIN#121

40177	40176	40175	40174	40173	40172	40171	40170
SIN#136	SIN#135	SIN#134	SIN#133	SIN#132	SIN#131	SIN#130	SIN#129
						OPE ORG RET R2	OPE ORG RET R1

4 System I/O Signals
 4.1 Common System Input Signals

40187	40186	40185	40184	40183	40182	40181	40180
SIN#144	SIN#143	SIN#142	SIN#141	SIN#140	SIN#139	SIN#138	SIN#137

40197	40196	40195	40194	40193	40192	40191	40190
SIN#152	SIN#151	SIN#150	SIN#149	SIN#148	SIN#147	SIN#146	SIN#145

40207	40206	40205	40204	40203	40202	40201	40200
SIN#160	SIN#159	SIN#158	SIN#157	SIN#156	SIN#155	SIN#154	SIN#153

40217	40216	40215	40214	40213	40212	40211	40210
SIN#168	SIN#167	SIN#166	SIN#165	SIN#164	SIN#163	SIN#162	SIN#161
		SYS ALM CODE					
		d5	d4	d3	d2	d1	d0

40227	40226	40225	40224	40223	40222	40221	40220
SIN#176	SIN#175	SIN#174	SIN#173	SIN#172	SIN#171	SIN#170	SIN#169
		USER ALM CODE					
		d5	d4	d3	d2	d1	d0

40237	40236	40235	40234	40233	40232	40231	40230
SIN#184	SIN#183	SIN#182	SIN#181	SIN#180	SIN#179	SIN#178	SIN#177
		SYS MSG CODE					
		d5	d4	d3	d2	d1	d0

40247	40246	40245	40244	40243	40242	40241	40240
SIN#192	SIN#191	SIN#190	SIN#189	SIN#188	SIN#187	SIN#186	SIN#185
		USER MSG CODE					
		d5	d4	d3	d2	d1	d0

40257	40256	40255	40254	40253	40252	40251	40250
SIN#200	SIN#199	SIN#198	SIN#197	SIN#196	SIN#195	SIN#194	SIN#193
		SUB5 EXT START	SUB4 EXT START	SUB3 EXT START	SUB2 EXT START	SUB1 EXT START	MASTER EXT START

40267	40266	40265	40264	40263	40262	40261	40260
SIN#208	SIN#207	SIN#206	SIN#205	SIN#204	SIN#203	SIN#202	SIN#201

40277	40276	40275	40274	40273	40272	40271	40270
SIN#216	SIN#215	SIN#214	SIN#213	SIN#212	SIN#211	SIN#210	SIN#209
		SUB5 EXT HOLD	SUB4 EXT HOLD	SUB3 EXT HOLD	SUB2 EXT HOLD	SUB1 EXT HOLD	MASTER EXT HOLD

40287	40286	40285	40284	40283	40282	40281	40280
SIN#224	SIN#223	SIN#222	SIN#221	SIN#220	SIN#219	SIN#218	SIN#217

40297	40296	40295	40294	40293	40292	40291	40290
SIN#232	SIN#231	SIN#230	SIN#229	SIN#228	SIN#227	SIN#226	SIN#225

40307	40306	40305	40304	40303	40302	40301	40300
SIN#240	SIN#239	SIN#238	SIN#237	SIN#236	SIN#235	SIN#234	SIN#233

40317	40316	40315	40314	40313	40312	40311	40310
SIN#248	SIN#247	SIN#246	SIN#245	SIN#244	SIN#243	SIN#242	SIN#241

40327	40326	40325	40324	40323	40322	40321	40320
SIN#256	SIN#255	SIN#254	SIN#253	SIN#252	SIN#251	SIN#250	SIN#249

40337	40336	40335	40334	40333	40332	40331	40330
SIN#264	SIN#263	SIN#262	SIN#261	SIN#260	SIN#259	SIN#258	SIN#257

40347	40346	40345	40344	40343	40342	40341	40340
SIN#272	SIN#271	SIN#270	SIN#269	SIN#268	SIN#267	SIN#266	SIN#265

40357	40356	40355	40354	40353	40352	40351	40350
SIN#280	SIN#279	SIN#278	SIN#277	SIN#276	SIN#275	SIN#274	SIN#273

40367	40366	40365	40364	40363	40362	40361	40360
SIN#288	SIN#287	SIN#286	SIN#285	SIN#284	SIN#283	SIN#282	SIN#281

40377	40376	40375	40374	40373	40372	40371	40370
SIN#296	SIN#295	SIN#294	SIN#293	SIN#292	SIN#291	SIN#290	SIN#289

40387	40386	40385	40384	40383	40382	40381	40380
SIN#304	SIN#303	SIN#302	SIN#301	SIN#300	SIN#299	SIN#298	SIN#297

40397	40396	40395	40394	40393	40392	40391	40390
SIN#312	SIN#311	SIN#310	SIN#309	SIN#308	SIN#307	SIN#306	SIN#305

40407	40406	40405	40404	40403	40402	40401	40400
SIN#320	SIN#319	SIN#318	SIN#317	SIN#316	SIN#315	SIN#314	SIN#313

40417	40416	40415	40414	40413	40412	40411	40410
SIN#328	SIN#327	SIN#326	SIN#325	SIN#324	SIN#323	SIN#322	SIN#321

40427	40426	40425	40424	40423	40422	40421	40420
SIN#336	SIN#335	SIN#334	SIN#333	SIN#332	SIN#331	SIN#330	SIN#329

40437	40436	40435	40434	40433	40432	40431	40430
SIN#344	SIN#343	SIN#342	SIN#341	SIN#340	SIN#339	SIN#338	SIN#337

40447	40446	40445	40444	40443	40442	40441	40440
SIN#352	SIN#351	SIN#350	SIN#349	SIN#348	SIN#347	SIN#346	SIN#345

40457	40456	40455	40454	40453	40452	40451	40450
SIN#360	SIN#359	SIN#358	SIN#357	SIN#356	SIN#355	SIN#354	SIN#353

40467	40466	40465	40464	40463	40462	40461	40460
SIN#368	SIN#367	SIN#366	SIN#365	SIN#364	SIN#363	SIN#362	SIN#361

40477	40476	40475	40474	40473	40472	40471	40470
SIN#376	SIN#375	SIN#374	SIN#373	SIN#372	SIN#371	SIN#370	SIN#369

40487	40486	40485	40484	40483	40482	40481	40480
SIN#384	SIN#383	SIN#382	SIN#381	SIN#380	SIN#379	SIN#378	SIN#377

40497	40496	40495	40494	40493	40492	40491	40490
SIN#392	SIN#391	SIN#390	SIN#389	SIN#388	SIN#387	SIN#386	SIN#385

40507	40506	40505	40504	40503	40502	40501	40500
SIN#400	SIN#399	SIN#398	SIN#397	SIN#396	SIN#395	SIN#394	SIN#393

40517	40516	40515	40514	40513	40512	40511	40510
SIN#408	SIN#407	SIN#406	SIN#405	SIN#404	SIN#403	SIN#402	SIN#401

40527	40526	40525	40524	40523	40522	40521	40520
SIN#416	SIN#415	SIN#414	SIN#413	SIN#412	SIN#411	SIN#410	SIN#409
PP BUZZER							

40537	40536	40535	40534	40533	40532	40531	40530
SIN#424	SIN#423	SIN#422	SIN#421	SIN#420	SIN#419	SIN#418	SIN#417

40547	40546	40545	40544	40543	40542	40541	40540
SIN#432	SIN#431	SIN#430	SIN#429	SIN#428	SIN#427	SIN#426	SIN#425

40557	40556	40555	40554	40553	40552	40551	40550
SIN#440	SIN#439	SIN#438	SIN#437	SIN#436	SIN#435	SIN#434	SIN#433

40567	40566	40565	40564	40563	40562	40561	40560
SIN#448	SIN#447	SIN#446	SIN#445	SIN#444	SIN#443	SIN#442	SIN#441
							AUTO BACKUP

40577	40576	40575	40574	40573	40572	40571	40570
SIN#456	SIN#455	SIN#454	SIN#453	SIN#452	SIN#451	SIN#450	SIN#449

40587	40586	40585	40584	40583	40582	40581	40580
SIN#464	SIN#463	SIN#462	SIN#461	SIN#460	SIN#459	SIN#458	SIN#457
							ENERGY SAVE INHI

40597	40596	40595	40594	40593	40592	40591	40590
SIN#472	SIN#471	SIN#470	SIN#469	SIN#468	SIN#467	SIN#466	SIN#465

40607	40606	40605	40604	40603	40602	40601	40600
SIN#480	SIN#479	SIN#478	SIN#477	SIN#476	SIN#475	SIN#474	SIN#473
							I/O TRACE START

40617	40616	40615	40614	40613	40612	40611	40610
SIN#488	SIN#487	SIN#486	SIN#485	SIN#484	SIN#483	SIN#482	SIN#481

40627	40626	40625	40624	40623	40622	40621	40620
SIN#496	SIN#495	SIN#494	SIN#493	SIN#492	SIN#491	SIN#490	SIN#489

40637	40636	40635	40634	40633	40632	40631	40630
SIN#504	SIN#503	SIN#502	SIN#501	SIN#500	SIN#499	SIN#498	SIN#497

40647	40646	40645	40644	40643	40642	40641	40640
SIN#512	SIN#511	SIN#510	SIN#509	SIN#508	SIN#507	SIN#506	SIN#505

40657	40656	40655	40654	40653	40652	40651	40650
SIN#520	SIN#519	SIN#518	SIN#517	SIN#516	SIN#515	SIN#514	SIN#513

40667	40666	40665	40664	40663	40662	40661	40660
SIN#528	SIN#527	SIN#526	SIN#525	SIN#524	SIN#523	SIN#522	SIN#521

40677	40676	40675	40674	40673	40672	40671	40670
SIN#536	SIN#535	SIN#534	SIN#533	SIN#532	SIN#531	SIN#530	SIN#529

40687	40686	40685	40684	40683	40682	40681	40680
SIN#544	SIN#543	SIN#542	SIN#541	SIN#540	SIN#539	SIN#538	SIN#537

40697	40696	40695	40694	40693	40692	40691	40690
SIN#552	SIN#551	SIN#550	SIN#549	SIN#548	SIN#547	SIN#546	SIN#545

40707	40706	40705	40704	40703	40702	40701	40700
SIN#560	SIN#559	SIN#558	SIN#557	SIN#556	SIN#555	SIN#554	SIN#553

40717	40716	40715	40714	40713	40712	40711	40710
SIN#568	SIN#567	SIN#566	SIN#565	SIN#564	SIN#563	SIN#562	SIN#561

40727	40726	40725	40724	40723	40722	40721	40720
SIN#576	SIN#575	SIN#574	SIN#573	SIN#572	SIN#571	SIN#570	SIN#569

40737	40736	40735	40734	40733	40732	40731	40730
SIN#584	SIN#583	SIN#582	SIN#581	SIN#580	SIN#579	SIN#578	SIN#577

40747	40746	40745	40744	40743	40742	40741	40740
SIN#592	SIN#591	SIN#590	SIN#589	SIN#588	SIN#587	SIN#586	SIN#585

40757	40756	40755	40754	40753	40752	40751	40750
SIN#600	SIN#599	SIN#598	SIN#597	SIN#596	SIN#595	SIN#594	SIN#593

40767	40766	40765	40764	40763	40762	40761	40760
SIN#608	SIN#607	SIN#606	SIN#605	SIN#604	SIN#603	SIN#602	SIN#601

40777	40776	40775	40774	40773	40772	40771	40770
SIN#616	SIN#615	SIN#614	SIN#613	SIN#612	SIN#611	SIN#610	SIN#609

40787	40786	40785	40784	40783	40782	40781	40780
SIN#624	SIN#623	SIN#622	SIN#621	SIN#620	SIN#619	SIN#618	SIN#617

40797	40796	40795	40794	40793	40792	40791	40790
SIN#632	SIN#631	SIN#630	SIN#629	SIN#628	SIN#627	SIN#626	SIN#625

40807	40806	40805	40804	40803	40802	40801	40800
SIN#640	SIN#639	SIN#638	SIN#637	SIN#636	SIN#635	SIN#634	SIN#633

40817	40816	40815	40814	40813	40812	40811	40810
SIN#648	SIN#647	SIN#646	SIN#645	SIN#644	SIN#643	SIN#642	SIN#641

40827	40826	40825	40824	40823	40822	40821	40820
SIN#656	SIN#655	SIN#654	SIN#653	SIN#652	SIN#651	SIN#650	SIN#649

40837	40836	40835	40834	40833	40832	40831	40830
SIN#664	SIN#663	SIN#662	SIN#661	SIN#660	SIN#659	SIN#658	SIN#657

40847	40846	40845	40844	40843	40842	40841	40840
SIN#672	SIN#671	SIN#670	SIN#669	SIN#668	SIN#667	SIN#666	SIN#665

40857	40856	40855	40854	40853	40852	40851	40850
SIN#680	SIN#679	SIN#678	SIN#677	SIN#676	SIN#675	SIN#674	SIN#673

40867	40866	40865	40864	40863	40862	40861	40860
SIN#688	SIN#687	SIN#686	SIN#685	SIN#684	SIN#683	SIN#682	SIN#681

40877	40876	40875	40874	40873	40872	40871	40870
SIN#696	SIN#695	SIN#694	SIN#693	SIN#692	SIN#691	SIN#690	SIN#689

40887	40886	40885	40884	40883	40882	40881	40880
SIN#704	SIN#703	SIN#702	SIN#701	SIN#700	SIN#699	SIN#698	SIN#697

40897	40896	40895	40894	40893	40892	40891	40890
SIN#712	SIN#711	SIN#710	SIN#709	SIN#708	SIN#707	SIN#706	SIN#705

40907	40906	40905	40904	40903	40902	40901	40900
SIN#720	SIN#719	SIN#718	SIN#717	SIN#716	SIN#715	SIN#714	SIN#713

40917	40916	40915	40914	40913	40912	40911	40910
SIN#728	SIN#727	SIN#726	SIN#725	SIN#724	SIN#723	SIN#722	SIN#721

40927	40926	40925	40924	40923	40922	40921	40920
SIN#736	SIN#735	SIN#734	SIN#733	SIN#732	SIN#731	SIN#730	SIN#729

40937	40936	40935	40934	40933	40932	40931	40930
SIN#744	SIN#743	SIN#742	SIN#741	SIN#740	SIN#739	SIN#738	SIN#737

40947	40946	40945	40944	40943	40942	40941	40940
SIN#752	SIN#751	SIN#750	SIN#749	SIN#748	SIN#747	SIN#746	SIN#745

40957	40956	40955	40954	40953	40952	40951	40950
SIN#760	SIN#759	SIN#758	SIN#757	SIN#756	SIN#755	SIN#754	SIN#753

40967	40966	40965	40964	40963	40962	40961	40960
SIN#768	SIN#767	SIN#766	SIN#765	SIN#764	SIN#763	SIN#762	SIN#761

40977	40976	40975	40974	40973	40972	40971	40970
SIN#776	SIN#775	SIN#774	SIN#773	SIN#772	SIN#771	SIN#770	SIN#769

40987	40986	40985	40984	40983	40982	40981	40980
SIN#784	SIN#783	SIN#782	SIN#781	SIN#780	SIN#779	SIN#778	SIN#777

40997	40996	40995	40994	40993	40992	40991	40990
SIN#792	SIN#791	SIN#790	SIN#789	SIN#788	SIN#787	SIN#786	SIN#785

41007	41006	41005	41004	41003	41002	41001	41000
SIN#800	SIN#799	SIN#798	SIN#797	SIN#796	SIN#795	SIN#794	SIN#793

41017	41016	41015	41014	41013	41012	41011	41010
SIN#808	SIN#807	SIN#806	SIN#805	SIN#804	SIN#803	SIN#802	SIN#801

41027	41026	41025	41024	41023	41022	41021	41020
SIN#816	SIN#815	SIN#814	SIN#813	SIN#812	SIN#811	SIN#810	SIN#809

41037	41036	41035	41034	41033	41032	41031	41030
SIN#824	SIN#823	SIN#822	SIN#821	SIN#820	SIN#819	SIN#818	SIN#817

41047	41046	41045	41044	41043	41042	41041	41040
SIN#832	SIN#831	SIN#830	SIN#829	SIN#828	SIN#827	SIN#826	SIN#825

41057	41056	41055	41054	41053	41052	41051	41050
SIN#840	SIN#839	SIN#838	SIN#837	SIN#836	SIN#835	SIN#834	SIN#833

41067	41066	41065	41064	41063	41062	41061	41060
SIN#848	SIN#847	SIN#846	SIN#845	SIN#844	SIN#843	SIN#842	SIN#841

41077	41076	41075	41074	41073	41072	41071	41070
SIN#856	SIN#855	SIN#854	SIN#853	SIN#852	SIN#851	SIN#850	SIN#849

41087	41086	41085	41084	41083	41082	41081	41080
SIN#864	SIN#863	SIN#862	SIN#861	SIN#860	SIN#859	SIN#858	SIN#857

41097	41096	41095	41094	41093	41092	41091	41090
SIN#872	SIN#871	SIN#870	SIN#869	SIN#868	SIN#867	SIN#866	SIN#865

41107	41106	41105	41104	41103	41102	41101	41100
SIN#880	SIN#879	SIN#878	SIN#877	SIN#876	SIN#875	SIN#874	SIN#873

41117	41116	41115	41114	41113	41112	41111	41110
SIN#888	SIN#887	SIN#886	SIN#885	SIN#884	SIN#883	SIN#882	SIN#881

41127	41126	41125	41124	41123	41122	41121	41120
SIN#896	SIN#895	SIN#894	SIN#893	SIN#892	SIN#891	SIN#890	SIN#889

4.2 System Input Signals for Operations

4.2.1 Device 1

41137	41136	41135	41134	41133	41132	41131	41130
SIN#904	SIN#903	SIN#902	SIN#901	SIN#900	SIN#899	SIN#897	SIN#897
					TIME MEASURE:1	END WORK ANS:1	START WORK ANS:1
41147	41146	41145	41144	41143	41142	41141	41140
SIN#912	SIN#911	SIN#910	SIN#909	SIN#908	SIN#907	SIN#906	SIN#905
41157	41156	41155	41154	41153	41152	41151	41150
SIN#920	SIN#919	SIN#918	SIN#917	SIN#916	SIN#915	SIN#914	SIN#913
41167	41166	41165	41164	41163	41162	41161	41160
SIN#928	SIN#927	SIN#926	SIN#925	SIN#924	SIN#923	SIN#922	SIN#921
41177	41176	41175	41174	41173	41172	41171	41170
SIN#936	SIN#935	SIN#934	SIN#933	SIN#932	SIN#931	SIN#930	SIN#929
41187	41186	41185	41184	41183	41182	41181	41180
SIN#944	SIN#943	SIN#942	SIN#941	SIN#940	SIN#939	SIN#938	SIN#937

4.2.2 Device 2

41197	41196	41195	41194	41193	41192	41191	41190
SIN#952	SIN#951	SIN#950	SIN#949	SIN#948	SIN#947	SIN#946	SIN#945
					TIME MEASURE:2	END WORK ANS:2	START WORK ANS:2
41207	41206	41205	41204	41203	41202	41201	41200
SIN#960	SIN#959	SIN#958	SIN#957	SIN#956	SIN#955	SIN#954	SIN#953
41217	41216	41215	41214	41213	41212	41211	41210
SIN#968	SIN#967	SIN#966	SIN#965	SIN#964	SIN#963	SIN#962	SIN#961
41227	41226	41225	41224	41223	41222	41221	41220
SIN#976	SIN#975	SIN#974	SIN#973	SIN#972	SIN#971	SIN#970	SIN#969
41237	41236	41235	41234	41233	41232	41231	41230
SIN#984	SIN#983	SIN#982	SIN#981	SIN#980	SIN#979	SIN#978	SIN#977
41247	41246	41245	41244	41243	41242	41241	41240
SIN#992	SIN#991	SIN#990	SIN#989	SIN#988	SIN#987	SIN#986	SIN#985

4.3 Description of System Input Signals

The following symbols are used in the explanation to represent the signal condition.



The signal takes effect while it is in ON state.



The rising edge is detected as the signal.

4.3.1 Alarm and Message Display

Various information items about the application can be displayed as messages on the programming pendant screen of the FS100. This section explains how to select already created messages. For registration, refer to “Registration of I/O Alarms and Messages”.

Fig. 4-1: Signal Timing

- Display request signal is a state signal, which continues to update the display while the signal is ON.

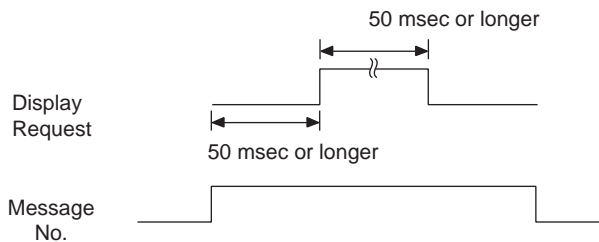

■ 40010: SYSTEM ALM REQ



When this signal is ON, a system alarm occurs and the manipulator stops. At the same time, an alarm message corresponding to the alarm code of the specific inputs (40210 to 40215) appears on the programming pendant screen.

40210 to 40215: SYS ALM CODE

Up to 64 system alarms can be specified. Assign messages by coding decimals from 0 to 63 into binaries.

No.	Setting Value 0: OFF 1: ON					
	40215	40214	40213	40212	40211	40210
0	0	0	0	0	0	0
1	0	0	0	0	0	1
2	0	0	0	0	1	0
3	0	0	0	0	1	1
:	:	:	:	:	:	:
63	1	1	1	1	1	1

■ **40011: SYSTEM MSG REQ**



When this signal is on, the message of the corresponding message code of specific inputs (40230 to 40235) appears on the programming pendant screen.

Manipulator operation will not be affected even if the message is displayed.

40230 to 40235: SYS MSG CODE

Up to 64 system messages can be specified. Assign messages by coding decimals from 0 to 63 into binaries.

No.	Setting Value 0: OFF 1: ON					
	40235	40234	40233	40232	40231	40230
0	0	0	0	0	0	0
1	0	0	0	0	0	1
2	0	0	0	0	1	0
3	0	0	0	0	1	1
:	:	:	:	:	:	:
63	1	1	1	1	1	1

■ **40012: USER ALM REQ**



When this signal is on, a user alarm occurs and the manipulator stops. At the same time, an alarm message corresponding to the alarm code of the specific input (40220 to 40225) appears on the programming pendant screen.

40220 to 40225: USER ALM CODE

Up to 64 system alarms can be specified. Assign messages by coding decimals from 0 to 63 into binaries.

No.	Setting Value 0: OFF 1: ON					
	40225	40224	40223	40222	40221	40220
0	0	0	0	0	0	0
1	0	0	0	0	0	1
2	0	0	0	0	1	0
3	0	0	0	0	1	1
:	:	:	:	:	:	:
63	1	1	1	1	1	1

■ **40013: USER MSG REQ**



When this signal is on, the message of the corresponding message code of specific inputs (40240 to 40245) appears on the programming pendant screen.

Manipulator operation will not be affected even if the message is displayed.

40240 to 40245: USER MSG CODE

Up to 64 user messages can be specified. Assign messages by coding decimals from 0 to 63 into binaries.

No.	Setting Value 0: OFF 1: ON					
	40245	40244	40243	40242	40241	40240
0	0	0	0	0	0	0
1	0	0	0	0	0	1
2	0	0	0	0	1	0
3	0	0	0	0	1	1
:	:	:	:	:	:	:
63	1	1	1	1	1	1

■ **40014: ALM/ERR RESET**



This signal clears alarms or errors when there is a minor failure, system alarm, user alarm, or user error. Use this signal when desiring to reset an alarm or error from the outside.

<Example>

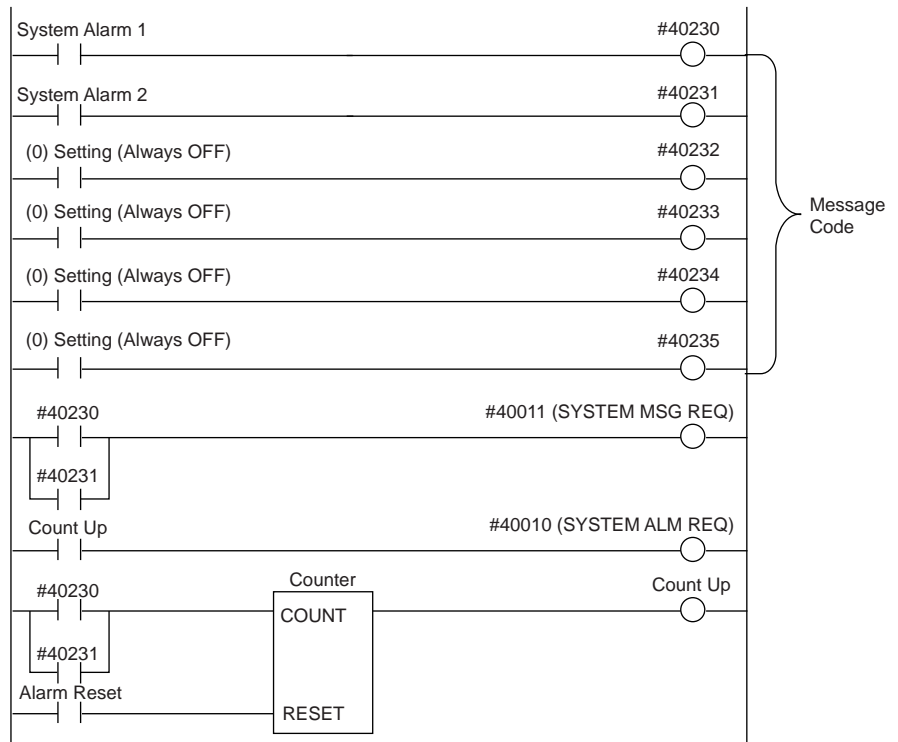

FS100	4	System I/O Signals
	4.3	Description of System Input Signals

4.3.2 Mode and Cycle Selection and Master Job Call

■ **40070: MASTER JOB CALL**



This signal resets the operating sequence. When the signal is on, the heading of the master job (Line: 0) will be called up as an execution job. This can be used for executing system initialization automatically when the power is turned on.

However, it is invalid in the following cases:

- While the manipulator is operating (job is executing)
- While the servo power is ON in the teach mode.
- “MASTER CALLING UP PROHIBIT” is shown on the operating condition window.

■ **40040, 40041: Mode Selection**



These signals have the same function as the mode key on the programming pendant. Use these signals when desiring to change mode specifications from the outside.

If two or more modes are specified at the same time, TEACH MODE has a priority over another.

They are invalid when “EXT. MODE SWITCH PROHIBIT” is shown on the operating condition window, and when the mode key on the programming pendant is set to “TEACH” or “PLAY”. (The mode specified with the mode key prevails.)

■ **40042, 40056, 40057: Operating Mode Selection**



40042 CMD REMOTE SEL

This signal selects a command remote function such as transmission. When the system transmission function (optional) is valid, “CMD REMOTE SETTING” (50056) signal goes on and the FS100 gets ready for transmission with the master computer.

40056 INHIBIT PP/PANEL

When this signal is on, cycle, start and servo on master job call from the programming pendant are prohibited. However, this prohibition is released by setting the PP Operation at Remote Mode parameter (S2C230).

40057 INHIBIT IO

When this signal is on, the following operation from external input is prohibited.

- Selection of Cycle (40050 to 40052)
- Calling Up Master Job (40070)
- External Servo On (40045)
- External Start (40044)

Fig. 4-2: Operation Mode Processing Standard Ladders

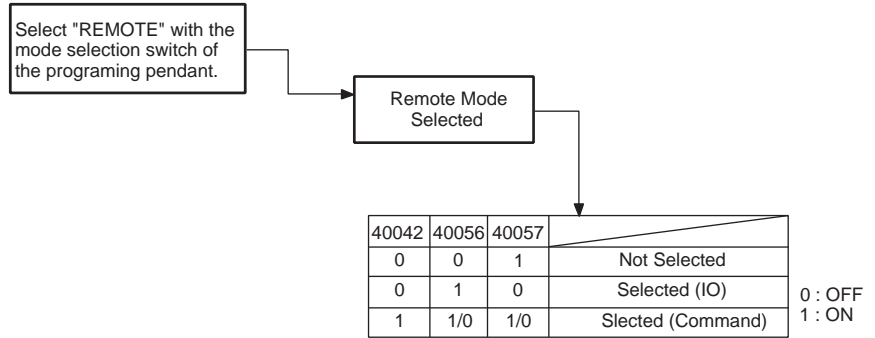

- For remote function selection, refer to the “Chapter 7 “Pseudo Input Signals”.
- Transmission function is an optional function.

■ **40050 to 40052: Cycle Selection**



Use the signals when desiring to change cycle specifications from the outside. These can also be used when desiring to fix a specified cycle.

If two or more cycles are specified at the same time, or it is operated with the programming pendant at the same time, the cycle will not change.

These are invalid when “EXT. MODE SWITCH PROHIBIT” is shown on the operating condition window.

4.3.3 Start and Stop

■ 40044: EXT START



This signal has the same function as the “START” button on the programming pendant. Automatic operation starts in accordance with cycle specifications. When this signal is accepted, “OPERATING” (50070) and “PERMISSIBLE WORK OPERATING” (50490) signals will be turned on. The signal can be used when starting from a panel other than the FS100 programming pendant such as an external operator’s panel. Since only one place on the programming pendant or external input can be specified as the “STARTING” base from the stand point of safety, specify “EXTERNAL START PROHIBIT” on the operating condition window.

This signal is invalid under the following conditions:

- Servo power supply is turned off.
- Remote mode is not selected.
- “EXTERNAL START PROHIBIT” is on the operating condition window.
- Manipulator is still operating. [When “OPERATING” (50070) signal is on].
- When “HOLDING” (50071) signal is on.
- “EXTERNAL HOLD” (40067) signal is on.

■ 40045: EXT SERVO ON



This signal turns on the servo power. Use the signal when turning on the servo power from the external device.

This signal is invalid when “EXT. MODE SWITCH PROHIBIT” is shown on the operating condition window.

■ 40054, 40065, 40066: EXT SERVO OFF



When these signals are on, the servo power supply is cut off and the manipulator stops. Use the signals when desiring to cut off the servo power supply from the external device or by ladder conditions for reasons other than the emergency stop. While these signals are on, the servo power remains off even if the servo on reference (from the programming pendant, or external device) is turned on.

40065: EXT SERVO OFF1 (Deceleration stop)

40066: EXT SERVO OFF2 (Emergency stop category 0)

40054: EXT SERVO OFF3 (Emergency stop category 1)

■ 40067: EXT HOLD



This signal has the same function as the “HOLD” button on the programming pendant. Use the signal when instructing “HOLD” from a device other than the programming pendant. While the signal is on, the “HOLD” lamp on the programming pendant is blinking and the “HOLD” (50071) signal goes ON.

4.3.4 Operation Command

- **40016: SPEED LIMIT**



When this signal is on, the playback operating speed is limited by in-guard safe operation speed. If approaching the manipulator during operation for unavoidable reasons, the operating speed can be limited by turning the signal on. It will therefore be convenient to interlink the signal with the safety guardrail or safety mat.



This signal is only to limit speed. Since the manipulator operates as taught, prepare the “EMERGENCY STOP” button so that it can be pressed at any time in the event of an emergency when one approaches the robot.

- **40046: CHECK-RUN**



This signal is not a start instruction. When the signal is on, the work instruction in the job is not executed. Use the signal to check the taught steps and motions. This signal is invalid when “CHECK/ MACHINE LOCK PROHIBIT” on the operating condition window is on.

- **40060: MACHINE-LOCK**



When this signal is on, the machine lock mode is selected.

- **40061: SHOCK DTCT OFF**



When this signal is on, the shock detection function is invalid.

- **40063: OT RELEASE REQ**



When this signal is on, the overrun status is released.

This signal has the same function as the overrun release operation in the overrun and shock sensor release window; however, setting the value for S2C575 allows whether to enable the function depending on the window displayed on the programming pendant screen.

0: Standard (The function is enabled when any window is displayed)

1: Enabled with interface panel (The function is enabled only when interface panel is displayed)

- **40064: EDIT LOCK**



When this signal is on, the job editing operation is prohibited.

■ **40090 to 40091: STEP BACK**



When these signals are on at start up, the manipulator moves to one step before the displayed step at low speed and stops there disregarding the cycle. These can be used for performing the operation one step before since some operations are difficult to be executed.

For a system with one manipulator, use signal No. 40090 (Robot 1 Job).

■ **40130 to 40131: WAIT JOB SEQ**



The manipulator pauses while this signal is on. Although it is functionally the same as "HOLD", it differs in the following ways:

When these signals are turned on while the manipulator is operating, the manipulator pauses temporarily, but it is still in an operating state. If these signals are turned on during an instruction other than a moving instruction (MOV), the instruction is continued. The "START" lamp remains lit and the "OPERATING" signal remains ON. If these signals are turned on while the manipulator is operating at high speed, the manipulator reduces its speed and stops.

The status of these signals are controlled. Motion of the manipulator is automatically resumed when changing from on to off.

For a system with one manipulator, use signal No. 40130 (Robot 1 Job).

<Example>

The following is an example of using the signal to check Cube Interference.

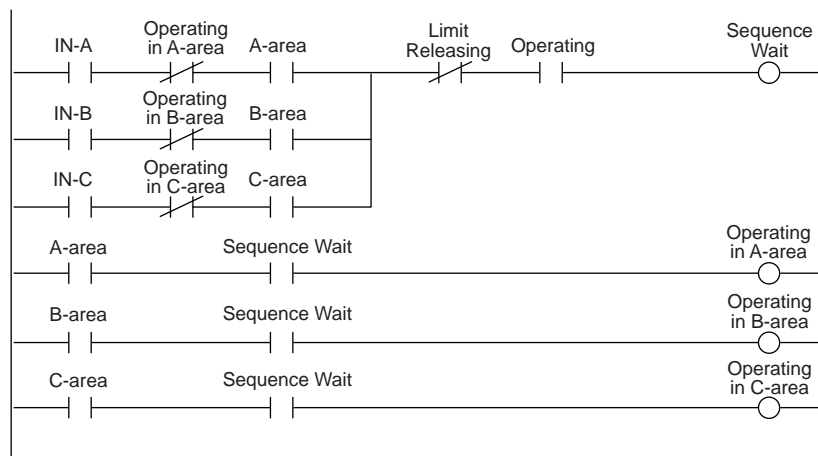

Descriptions of ladder

Meaning of above terms	
A, B, C:	Area Name e.g. Cube 1, etc.
IN-A, IN-B, IN-C:	Status of the combined equipment input externally
Area A, Area B, Area C:	Individual status signals The signals indicate whether the manipulator is in the area.
Operating in A-area, Operating in B-area, Operating in C-area:	ON when operating in the area The signals are assigned to the combined equipment.

If the signal “Area A”, “Area B”, or “Area C” is turned on while the combined equipment is outside the area, the signal “Operating in A-area”, “Operating in B-area”, or “Operating in C-area” is turned ON and the operation continues.

If the combined equipment is in the area first, the SEQUENCE WAIT signal goes ON and robot operation is stopped until the combined equipment leaves the area. When the combined equipment leaves the area, the SEQUENCE WAIT signal goes off and manipulator operation resumes.

■ **40170 to 40171: OPE ORG RET**



The manipulator moves to the work home position at the speed of parameter SICxG056 at joint operation by starting up these signals in the play mode.

During returning to the home position, the “START” lamp is lit (“during start” is entered) and the message “Operation Origin Returning” is displayed on the programming pendant screen.

Do not use these signals unless interlocking to check that the manipulator is at a position from which it can return to the home position.

For a system with one manipulator, use signal No. 40170.

■ **40527: PP BUZZER**



When this signal is on, the buzzer of programming pendant sounds.

4.3.5 Independent Control Signals (Optional)

■ **40021 to 40025: SUB (1 to 5) ALM REQ**



These signals are used to stop the specified sub task with an alarm when system section alarm request (40010) or user section alarm request (40012) is issued.

Input the alarm request (40010 or 40012) after setting the conditions of individual requirements.

■ **40071 to 40075: SUB (1 to 5) MASTER CALL**



Operation sequence is reset. When these signals are turned on, the head of the master job in sub take 1 to 5 is called up as an execution job.

These signals are invalid in any of the following cases:

- The manipulator is operating (during job execution).
- While the servo power is on in the teach mode.
- “MASTER CALLING UP PROHIBIT” is shown on the operating condition window.
- Master job is not registered.

■ **40250 to 40255: MASTER or SUB (1 to 5) EXT START**



When the signals are turned on, the robot starts its operation automatically by each sub task 1 to 5 and the master job individually. When the signals are accepted, the signals “RUN”, 50640 to 50645 are turned on. The signals can be used when starting from a panel such as an external operator’s panel other than the FS100 programming pendant. Specify the condition on the operating condition window.

These signals are invalid in any of the following cases:

- The servo power is not turned on.
- The PLAY mode is not set.
- The “EXTERNAL START PROHIBIT” is shown on the operating condition window.
- The corresponding signal “RUN” is on. That is the robot is operating.
- The signal “HOLDING” is on.
- The signal “EXTERNAL HOLD” is on.
- The corresponding signal “HOLDING” is on.

■ **40270 to 40275: MASTER or SUB (1 to 5) EXT HOLD**



When these signals are turned on, the manipulator, which is running individually in accordance with each sub task 1 to 5 and the master job, pauses. The corresponding signal “HOLD” (50660 to 50665) is turned on when this signal is ON.

■ **40580: ENERGY SAVE INHI**



When this signal is on, the energy saving is prohibited.

■ **40600: I/O TRACE START**



When this signal is on, the trace starts.

FS100	4	System I/O Signals
	4.3	Description of System Input Signals

4.3.6 Signals for Operations

Signals from 41130 to 41247 are classified into two blocks and assigned to input signals that have each different meanings depending on the application.

- **41130, 41190: START WORK ANS**



These signals are used for response to “START WORK” (51530, 51590) signal. The work start instruction is completed by the response.

For a system with one manipulator, use signal No. 41130.

- **41131, 41191: END WORK ANS**



These signals are used for response to “END WORK” (51531, 51591) signal.

For a system with one manipulator, use signal No. 41131.

- **41132, 41192: TIME MEASURE**



The time during which these signals are on is measured as the operating time.

This operating time can be checked on the system monitoring time window.

For a system with one manipulator, use signal No. 41132.

4.4 Common System Output Signals

50017	50016	50015	50014	50013	50012	50011	50010
SOUT#008	SOUT#007	SOUT#006	SOUT#005	SOUT#004	SOUT#003	SOUT#002	SOUT#001
COOLING FAN ERR	ENCDR BTRY WEAK	MEMORY BTRY WEAK	ERROR OCCUR	USER ALM OCCUR	SYSTEM ALM OCCUR	MINOR ALM OCCUR	MAJOR ALM OCCUR

50027	50026	50025	50024	50023	50022	50021	50020
SOUT#016	SOUT#015	SOUT#014	SOUT#013	SOUT#012	SOUT#011	SOUT#010	SOUT#009
		TOP SUB5 MASTER	TOP SUB4 MASTER	TOP SUB3 MASTER	TOP SUB2 MASTER	TOP SUB1 MASTER	TOP MASTER JOB

50037	50036	50035	50034	50033	50032	50031	50030
SOUT#024	SOUT#023	SOUT#022	SOUT#021	SOUT#020	SOUT#019	SOUT#018	SOUT#017

50047	50046	50045	50044	50043	50042	50041	50040
SOUT#032	SOUT#031	SOUT#030	SOUT#029	SOUT#028	SOUT#027	SOUT#026	SOUT#025

50057	50056	50055	50054	50053	50052	50051	50050
SOUT#040	SOUT#039	SOUT#038	SOUT#037	SOUT#036	SOUT#035	SOUT#034	SOUT#033
	CMD REMOTE SET	SYSTEM RUNNING	PLAY MODE SET	TEACH MODE SET	CONT CYCLE SET	1-CYCLE SET	STEP CYCLE SET

50067	50066	50065	50064	50063	50062	50061	50060
SOUT#048	SOUT#047	SOUT#046	SOUT#045	SOUT#044	SOUT#043	SOUT#042	SOUT#041
FULL SPEED TEST	POSITION CHECKED		CHECK-RUN SET	LIMIT OPEN SET	MACHINE-LOCK SET	DRY-RUN SET	SPEED LIMIT

50077	50076	50075	50074	50073	50072	50071	50070
SOUT#056	SOUT#055	SOUT#054	SOUT#053	SOUT#052	SOUT#051	SOUT#050	SOUT#049
OT RELEASE	JOG OPN INFORM	JOB EDIT INFORM	I/O SIMULATED	SERVO ON		HOLD (Hold Lamp)	RUN (Start Lamp)

50087	50086	50085	50084	50083	50082	50081	50080
SOUT#064	SOUT#063	SOUT#062	SOUT#061	SOUT#060	SOUT#059	SOUT#058	SOUT#057
CUBE/AXIS INTR							
8	7	6	5	4	3	2	1

50097	50096	50095	50094	50093	50092	50091	50090
SOUT#072	SOUT#071	SOUT#070	SOUT#069	SOUT#068	SOUT#067	SOUT#066	SOUT#065
CUBE/AXIS INTR							
16	15	14	13	12	11	10	9

50107	50106	50105	50104	50103	50102	50101	50100
SOUT#080	SOUT#079	SOUT#078	SOUT#077	SOUT#076	SOUT#075	SOUT#074	SOUT#073
CUBE/AXIS INTR							
24	23	22	21	20	19	18	17

50117	50116	50115	50114	50113	50112	50111	50110
SOUT#088	SOUT#087	SOUT#086	SOUT#085	SOUT#084	SOUT#083	SOUT#082	SOUT#081
CUBE/AXIS INTR							
32	31	30	29	28	27	26	25

50127	50126	50125	50124	50123	50122	50121	50120
SOUT#096	SOUT#095	SOUT#094	SOUT#093	SOUT#092	SOUT#091	SOUT#090	SOUT#089
CUBE/AXIS INTR							
40	39	38	37	36	35	34	33

50137	50136	50135	50134	50133	50132	50131	50130
SOUT#104	SOUT#103	SOUT#102	SOUT#101	SOUT#100	SOUT#099	SOUT#098	SOUT#097
CUBE/AXIS INTR							
48	47	46	45	44	43	42	41

50147	50146	50145	50144	50143	50142	50141	50140
SOUT#112	SOUT#111	SOUT#110	SOUT#109	SOUT#108	SOUT#107	SOUT#106	SOUT#105
CUBE/AXIS INTR							
56	55	54	53	52	51	50	49

50157	50156	50155	50154	50153	50152	50151	50150
SOUT#120	SOUT#119	SOUT#118	SOUT#117	SOUT#116	SOUT#115	SOUT#114	SOUT#113
CUBE/AXIS INTR							
64	63	62	61	60	59	58	57

50167	50166	50165	50164	50163	50162	50161	50160
SOUT#128	SOUT#127	SOUT#126	SOUT#125	SOUT#124	SOUT#123	SOUT#122	SOUT#121

50177	50176	50175	50174	50173	50172	50171	50170
SOUT#136	SOUT#135	SOUT#134	SOUT#133	SOUT#132	SOUT#131	SOUT#130	SOUT#129

50187	50186	50185	50184	50183	50182	50181	50180
SOUT#144	SOUT#143	SOUT#142	SOUT#141	SOUT#140	SOUT#139	SOUT#138	SOUT#137
						CRD WORK R1, R2	

50197	50196	50195	50194	50193	50192	50191	50190
SOUT#152	SOUT#151	SOUT#150	SOUT#149	SOUT#148	SOUT#147	SOUT#146	SOUT#145

50207	50206	50205	50204	50203	50202	50201	50200
SOUT#160	SOUT#159	SOUT#158	SOUT#157	SOUT#156	SOUT#155	SOUT#154	SOUT#153

50217	50216	50215	50214	50213	50212	50211	50210
SOUT#168	SOUT#167	SOUT#166	SOUT#165	SOUT#164	SOUT#163	SOUT#162	SOUT#161

50227	50226	50225	50224	50223	50222	50221	50220
SOUT#176	SOUT#175	SOUT#174	SOUT#173	SOUT#172	SOUT#171	SOUT#170	SOUT#169

50237	50236	50235	50234	50233	50232	50231	50230
SOUT#184	SOUT#183	SOUT#182	SOUT#181	SOUT#180	SOUT#179	SOUT#178	SOUT#177

50247	50246	50245	50244	50243	50242	50241	50240
SOUT#192	SOUT#191	SOUT#190	SOUT#189	SOUT#188	SOUT#187	SOUT#186	SOUT#185

50257	50256	50255	50254	50253	50252	50251	50250
SOUT#200	SOUT#199	SOUT#198	SOUT#197	SOUT#196	SOUT#195	SOUT#194	SOUT#193

50267	50266	50265	50264	50263	50262	50261	50260
SOUT#208	SOUT#207	SOUT#206	SOUT#205	SOUT#204	SOUT#203	SOUT#202	SOUT#201

50277	50276	50275	50274	50273	50272	50271	50270
SOUT#216	SOUT#215	SOUT#214	SOUT#213	SOUT#212	SOUT#211	SOUT#210	SOUT#209

50287	50286	50285	50284	50283	50282	50281	50280
SOUT#224	SOUT#223	SOUT#222	SOUT#221	SOUT#220	SOUT#219	SOUT#218	SOUT#217

50297	50296	50295	50294	50293	50292	50291	50290
SOUT#232	SOUT#231	SOUT#230	SOUT#229	SOUT#228	SOUT#227	SOUT#226	SOUT#225

50307	50306	50305	50304	50303	50302	50301	50300
SOUT#240	SOUT#239	SOUT#238	SOUT#237	SOUT#236	SOUT#235	SOUT#234	SOUT#233

50317	50316	50315	50314	50313	50312	50311	50310
SOUT#248	SOUT#247	SOUT#246	SOUT#245	SOUT#244	SOUT#243	SOUT#242	SOUT#241

50327	50326	50325	50324	50323	50322	50321	50320
SOUT#256	SOUT#255	SOUT#254	SOUT#253	SOUT#252	SOUT#251	SOUT#250	SOUT#249
						SERVO ON R2	SERVO ON R1

50337	50336	50335	50334	50333	50332	50331	50330
SOUT#264	SOUT#263	SOUT#262	SOUT#261	SOUT#260	SOUT#259	SOUT#258	SOUT#257
					SERVO ON S3	SERVO ON S2	SERVO ON S1

50347	50346	50345	50344	50343	50342	50341	50340
SOUT#272	SOUT#271	SOUT#270	SOUT#269	SOUT#268	SOUT#237	SOUT#266	SOUT#265

50357	50356	50355	50354	50353	50352	50351	50350
SOUT#280	SOUT#279	SOUT#278	SOUT#277	SOUT#276	SOUT#275	SOUT#274	SOUT#273

50367	50366	50365	50364	50363	50362	50361	50360
SOUT#288	SOUT#287	SOUT#286	SOUT#285	SOUT#284	SOUT#283	SOUT#282	SOUT#281
						WAIT JOB SEQ R2J	WAIT JOB SEQ R1J

50377	50376	50375	50374	50373	50372	50371	50370
SOUT#296	SOUT#295	SOUT#294	SOUT#293	SOUT#292	SOUT#291	SOUT#290	SOUT#289
					WAIT JOB SEQ S3J	WAIT JOB SEQ S2J	WAIT JOB SEQ S1J

50387	50386	50385	50384	50383	50382	50381	50380
SOUT#304	SOUT#303	SOUT#302	SOUT#301	SOUT#300	SOUT#299	SOUT#298	SOUT#297

50397	50396	50395	50394	50393	50392	50391	50390
SOUT#312	SOUT#311	SOUT#310	SOUT#309	SOUT#308	SOUT#307	SOUT#306	SOUT#305

50407	50406	50405	50404	50403	50402	50401	50400
SOUT#320	SOUT#319	SOUT#318	SOUT#317	SOUT#316	SOUT#315	SOUT#314	SOUT#313
						CONT JOB SEQ R2J	CONT JOB SEQ R1J

50417	50416	50415	50414	50413	50412	50411	50410
SOUT#328	SOUT#327	SOUT#326	SOUT#325	SOUT#324	SOUT#323	SOUT#322	SOUT#321
					CONT JOB SEQ S3J	CONT JOB SEQ S2J	CONT JOB SEQ S1J

50427	50426	50425	50424	50423	50422	50421	50420
SOUT#336	SOUT#335	SOUT#334	SOUT#333	SOUT#332	SOUT#331	SOUT#330	SOUT#329

50437	50436	50435	50434	50433	50432	50431	50430
SOUT#344	SOUT#343	SOUT#342	SOUT#341	SOUT#340	SOUT#339	SOUT#338	SOUT#337

50447	50446	50445	50444	50443	50442	50441	50440
SOUT#352	SOUT#351	SOUT#350	SOUT#349	SOUT#348	SOUT#347	SOUT#346	SOUT#345
						CTRL GRP RUN R2	CTRL GRP RUN R1

50457	50456	50455	50454	50453	50452	50451	50450
SOUT#360	SOUT#359	SOUT#358	SOUT#357	SOUT#356	SOUT#355	SOUT#354	SOUT#353
					CTRL GRP RUN S3	CTRL GRP RUN S2	CTRL GRP RUN S1

50467	50466	50465	50464	50463	50462	50461	50460
SOUT#368	SOUT#367	SOUT#366	SOUT#365	SOUT#364	SOUT#363	SOUT#362	SOUT#361

50477	50476	50475	50474	50473	50472	50471	50470
SOUT#376	SOUT#375	SOUT#374	SOUT#373	SOUT#372	SOUT#371	SOUT#370	SOUT#369

50487	50486	50485	50484	50483	50482	50481	50480
SOUT#384	SOUT#383	SOUT#382	SOUT#381	SOUT#380	SOUT#379	SOUT#378	SOUT#377
						NO WRK RESTRT R2	NO WRK RESTRT R1

50497	50496	50495	50494	50493	50492	50491	50490
SOUT#392	SOUT#391	SOUT#390	SOUT#389	SOUT#388	SOUT#387	SOUT#386	SOUT#385
						WORK PRMT RUN R2	WORK PRMT RUN R1

50507	50506	50505	50504	50503	50502	50501	50500
SOUT#400	SOUT#399	SOUT#398	SOUT#397	SOUT#396	SOUT#395	SOUT#394	SOUT#393
						SEARCHING R2J	SEARCHING R1J

50517	50516	50515	50514	50513	50512	50511	50510
SOUT#408	SOUT#407	SOUT#406	SOUT#405	SOUT#404	SOUT#403	SOUT#402	SOUT#401
						SERVOFLOAT ON R2	SERVOFLOAT ON R1

50527	50526	50525	50524	50523	50522	50521	50520
SOUT#416	SOUT#415	SOUT#414	SOUT#413	SOUT#412	SOUT#411	SOUT#410	SOUT#409
						LOCUS DEVIATE R2	LOCUS DEVIATE R1

50537	50536	50535	50534	50533	50532	50531	50530
SOUT#424	SOUT#423	SOUT#422	SOUT#421	SOUT#420	SOUT#419	SOUT#418	SOUT#417

50547	50546	50545	50544	50543	50542	50541	50540
SOUT#432	SOUT#431	SOUT#430	SOUT#429	SOUT#428	SOUT#427	SOUT#426	SOUT#425

50557	50556	50555	50554	50553	50552	50551	50550
SOUT#440	SOUT#439	SOUT#438	SOUT#437	SOUT#436	SOUT#435	SOUT#434	SOUT#433

50567	50566	50565	50564	50563	50562	50561	50560
SOUT#448	SOUT#447	SOUT#446	SOUT#445	SOUT#444	SOUT#443	SOUT#442	SOUT#441
						SHOCK DTCT ON:R2	SHOCK DTCT ON:R1

50577	50576	50575	50574	50573	50572	50571	50570
SOUT#456	SOUT#455	SOUT#454	SOUT#453	SOUT#452	SOUT#451	SOUT#450	SOUT#449

50587	50586	50585	50584	50583	50582	50581	50580
SOUT#464	SOUT#463	SOUT#462	SOUT#461	SOUT#460	SOUT#459	SOUT#458	SOUT#457

50597	50596	50595	50594	50593	50592	50591	50590
SOUT#472	SOUT#471	SOUT#470	SOUT#469	SOUT#468	SOUT#467	SOUT#466	SOUT#465

50607	50606	50605	50604	50603	50602	50601	50600
SOUT#480	SOUT#479	SOUT#478	SOUT#477	SOUT#476	SOUT#475	SOUT#474	SOUT#473
		SUB5 HELD	SUB4 HELD	SUB3 HELD	SUB2 HELD	SUB1 HELD	

50617	50616	50615	50614	50613	50612	50611	50610
SOUT#488	SOUT#487	SOUT#486	SOUT#485	SOUT#484	SOUT#483	SOUT#482	SOUT#481

50627	50626	50625	50624	50623	50622	50621	50620
SOUT#496	SOUT#495	SOUT#494	SOUT#493	SOUT#492	SOUT#491	SOUT#490	SOUT#489
		SUB5 ALM OCCUR	SUB4 ALM OCCUR	SUB3 ALM OCCUR	SUB2 ALM OCCUR	SUB1 ALM OCCUR	

50637	50636	50635	50634	50633	50632	50631	50630
SOUT#504	SOUT#503	SOUT#502	SOUT#501	SOUT#500	SOUT#499	SOUT#498	SOUT#497

50647	50646	50645	50644	50643	50642	50641	50640
SOUT#512	SOUT#511	SOUT#510	SOUT#509	SOUT#508	SOUT#507	SOUT#506	SOUT#505
		RUN (SUB5)	RUN (SUB4)	RUN (SUB3)	RUN (SUB2)	RUN (SUB1)	RUN (MASTER)

50657	50656	50655	50654	50653	50652	50651	50650
SOUT#520	SOUT#519	SOUT#518	SOUT#517	SOUT#516	SOUT#515	SOUT#514	SOUT#513

50667	50666	50665	50664	50663	50662	50661	50660
SOUT#528	SOUT#527	SOUT#526	SOUT#525	SOUT#524	SOUT#523	SOUT#522	SOUT#521
		HOLD (SUB5)	HOLD (SUB4)	HOLD (SUB3)	HOLD (SUB2)	HOLD (SUB1)	HOLD (MASTER)

50677	50676	50675	50674	50673	50672	50671	50670
SOUT#536	SOUT#535	SOUT#534	SOUT#533	SOUT#532	SOUT#531	SOUT#530	SOUT#529

50687	50686	50685	50684	50683	50682	50681	50680
SOUT#544	SOUT#543	SOUT#542	SOUT#541	SOUT#540	SOUT#539	SOUT#538	SOUT#537

50697	50696	50695	50694	50693	50692	50691	50690
SOUT#552	SOUT#551	SOUT#550	SOUT#549	SOUT#548	SOUT#547	SOUT#546	SOUT#545
SHOCK DTCT ALM	WRONG JOB DATA				MANAGEMENT MODE	EDITING MODE	OPERATION MODE

50707	50706	50705	50704	50703	50702	50701	50700
SOUT#560	SOUT#559	SOUT#558	SOUT#557	SOUT#556	SOUT#555	SOUT#554	SOUT#553
		SEL JOB (SUB5)	SEL JOB (SUB4)	SEL JOB (SUB3)	SEL JOB (SUB2)	SEL JOB (SUB1)	SEL JOB (MASTER)

50717	50716	50715	50714	50713	50712	50711	50710
SOUT#568	SOUT#567	SOUT#566	SOUT#565	SOUT#564	SOUT#563	SOUT#562	SOUT#561

50727	50726	50725	50724	50723	50722	50721	50720
SOUT#576	SOUT#575	SOUT#574	SOUT#573	SOUT#572	SOUT#571	SOUT#570	SOUT#569
ENERGY SAVING	MOTOR TEMP HIGH	OPEN DIALOG					

50737	50736	50735	50734	50733	5073	50731	50730
SOUT#584	SOUT#583	SOUT#582	SOUT#581	SOUT#580	SOUT#579	SOUT#578	SOUT#577

50747	50746	50745	50744	50743	50742	50741	50740
SOUT#592	SOUT#591	SOUT#590	SOUT#589	SOUT#588	SOUT#587	SOUT#586	SOUT#585

50757	50756	50755	50754	50753	50752	50751	50750
SOUT#600	SOUT#599	SOUT#598	SOUT#597	SOUT#596	SOUT#595	SOUT#594	SOUT#593

50767	50766	50765	50764	50763	50762	50761	50760
SOUT#608	SOUT#607	SOUT#606	SOUT#605	SOUT#604	SOUT#603	SOUT#602	SOUT#601

50777	50776	50775	50774	50773	50772	50771	50770
SOUT#616	SOUT#615	SOUT#614	SOUT#613	SOUT#612	SOUT#611	SOUT#610	SOUT#609
A.BACKUP DATA TR	A.BACKUP DATA MK						

50787	50786	50785	50784	50783	50782	50781	50780
SOUT#624	SOUT#623	SOUT#622	SOUT#621	SOUT#620	SOUT#619	SOUT#618	SOUT#617

50797	50796	50795	50794	50793	50792	50791	50790
SOUT#632	SOUT#631	SOUT#630	SOUT#629	SOUT#628	SOUT#627	SOUT#626	SOUT#625

50807	50806	50805	50804	50803	50802	50801	50800
SOUT#640	SOUT#639	SOUT#638	SOUT#637	SOUT#636	SOUT#635	SOUT#634	SOUT#633

50817	50816	50815	50814	50813	50812	50811	50810
SOUT#648	SOUT#647	SOUT#646	SOUT#645	SOUT#644	SOUT#643	SOUT#642	SOUT#641

50827	50826	50825	50824	50823	50822	50821	50820
SOUT#656	SOUT#655	SOUT#654	SOUT#653	SOUT#652	SOUT#651	SOUT#650	SOUT#649

50837	50836	50835	50834	50833	50832	50831	50830
SOUT#664	SOUT#663	SOUT#662	SOUT#661	SOUT#660	SOUT#659	SOUT#658	SOUT#657

50847	50846	50845	50844	50843	50842	50841	50840
SOUT#672	SOUT#671	SOUT#670	SOUT#669	SOUT#668	SOUT#667	SOUT#666	SOUT#665

50857	50856	50855	50854	50853	50852	50851	50850
SOUT#680	SOUT#679	SOUT#678	SOUT#677	SOUT#676	SOUT#675	SOUT#674	SOUT#673

50837	50836	50835	50834	50833	50832	50831	50830
SOUT#688	SOUT#687	SOUT#686	SOUT#685	SOUT#684	SOUT#683	SOUT#682	SOUT#681

50877	50876	50875	50874	50873	50872	50871	50870
SOUT#696	SOUT#695	SOUT#694	SOUT#693	SOUT#692	SOUT#691	SOUT#690	SOUT#689

50887	50886	50885	50884	50883	50882	50881	50880
SOUT#704	SOUT#703	SOUT#702	SOUT#701	SOUT#700	SOUT#699	SOUT#698	SOUT#697

50897	50896	50895	50894	50893	50892	50891	50890
SOUT#712	SOUT#711	SOUT#710	SOUT#709	SOUT#708	SOUT#707	SOUT#706	SOUT#705

50907	50906	50905	50904	50903	50902	50901	50900
SOUT#720	SOUT#719	SOUT#718	SOUT#717	SOUT#716	SOUT#715	SOUT#714	SOUT#713
							I/O TRACE MODE

50917	50916	50915	50914	50913	50912	50911	50910
SOUT#728	SOUT#727	SOUT#726	SOUT#725	SOUT#724	SOUT#723	SOUT#722	SOUT#721

50927	50926	50925	50924	50923	50922	50921	50920
SOUT#736	SOUT#735	SOUT#734	SOUT#733	SOUT#732	SOUT#731	SOUT#730	SOUT#729

50937	50936	50935	50934	50933	50932	50931	50930
SOUT#744	SOUT#743	SOUT#742	SOUT#741	SOUT#740	SOUT#739	SOUT#738	SOUT#737

50947	50946	50945	50944	50943	50942	50941	50940
SOUT#752	SOUT#751	SOUT#750	SOUT#749	SOUT#748	SOUT#747	SOUT#746	SOUT#745

50957	50956	50955	50954	50953	50952	50951	50950
SOUT#760	SOUT#759	SOUT#758	SOUT#757	SOUT#756	SOUT#755	SOUT#754	SOUT#753

50967	50966	50965	50964	50963	50962	50961	50960
SOUT#768	SOUT#767	SOUT#766	SOUT#765	SOUT#764	SOUT#763	SOUT#762	SOUT#761

50977	50976	50975	50974	50973	50972	50971	50970
SOUT#776	SOUT#775	SOUT#774	SOUT#773	SOUT#772	SOUT#771	SOUT#770	SOUT#769

50987	50986	50985	50984	50983	50982	50981	50980
SOUT#784	SOUT#783	SOUT#782	SOUT#781	SOUT#780	SOUT#779	SOUT#778	SOUT#777

50997	50996	50995	50994	50993	50992	50991	50990
SOUT#792	SOUT#791	SOUT#790	SOUT#789	SOUT#788	SOUT#787	SOUT#786	SOUT#785

51007	51006	51005	51004	51003	51002	51001	51000
SOUT#800	SOUT#799	SOUT#798	SOUT#797	SOUT#796	SOUT#795	SOUT#794	SOUT#793

51017	51016	51015	51014	51013	51012	51011	51010
SOUT#808	SOUT#807	SOUT#806	SOUT#805	SOUT#804	SOUT#803	SOUT#802	SOUT#801

51027	51026	51025	51024	51023	51022	51021	51020
SOUT#816	SOUT#815	SOUT#814	SOUT#813	SOUT#812	SOUT#811	SOUT#810	SOUT#809

51037	51036	51035	51034	51033	51032	51031	51030
SOUT#824	SOUT#823	SOUT#822	SOUT#821	SOUT#820	SOUT#819	SOUT#818	SOUT#817

51047	51046	51045	51044	51043	51042	51041	51040
SOUT#832	SOUT#831	SOUT#830	SOUT#829	SOUT#828	SOUT#827	SOUT#826	SOUT#825

51057	51056	51055	51054	51053	51052	51051	51050
SOUT#840	SOUT#839	SOUT#838	SOUT#837	SOUT#836	SOUT#835	SOUT#834	SOUT#833

51067	51066	51065	51064	51063	51062	51061	51060
SOUT#848	SOUT#847	SOUT#846	SOUT#845	SOUT#844	SOUT#843	SOUT#842	SOUT#841

51077	51076	51075	51074	51073	51072	51071	51070
SOUT#856	SOUT#855	SOUT#854	SOUT#853	SOUT#852	SOUT#851	SOUT#850	SOUT#849

51087	51086	51085	51084	51083	51082	51081	51080
SOUT#864	SOUT#863	SOUT#862	SOUT#861	SOUT#860	SOUT#859	SOUT#858	SOUT#857

51097	51096	51095	51094	51093	51092	51091	51090
SOUT#872	SOUT#871	SOUT#870	SOUT#869	SOUT#868	SOUT#867	SOUT#866	SOUT#865

51107	51106	51105	51104	51103	51102	51101	51100
SOUT#880	SOUT#879	SOUT#878	SOUT#877	SOUT#876	SOUT#875	SOUT#874	SOUT#873

51117	51116	51115	51114	51113	51112	51111	51110
SOUT#888	SOUT#887	SOUT#886	SOUT#885	SOUT#884	SOUT#883	SOUT#882	SOUT#881

51127	51126	51125	51124	51123	51122	51121	51120
SOUT#896	SOUT#895	SOUT#894	SOUT#893	SOUT#892	SOUT#891	SOUT#890	SOUT#889

51137	51136	51135	51134	51133	51132	51131	51130
SOUT#904	SOUT#903	SOUT#902	SOUT#901	SOUT#900	SOUT#899	SOUT#898	SOUT#897

51147	51146	51145	51144	51143	51142	51141	51140
SOUT#912	SOUT#911	SOUT#910	SOUT#909	SOUT#908	SOUT#907	SOUT#906	SOUT#905

51157	51156	51155	51154	51153	51152	51151	51150
SOUT#920	SOUT#919	SOUT#918	SOUT#917	SOUT#916	SOUT#915	SOUT#914	SOUT#913

51167	51166	51165	51164	51163	51162	51161	51160
SOUT#928	SOUT#927	SOUT#926	SOUT#925	SOUT#924	SOUT#923	SOUT#922	SOUT#921

51177	51176	51175	51174	51173	51172	51171	51170
SOUT#936	SOUT#935	SOUT#934	SOUT#933	SOUT#932	SOUT#931	SOUT#930	SOUT#929

51187	51186	51185	51184	51183	51182	51181	51180
SOUT#944	SOUT#943	SOUT#942	SOUT#941	SOUT#940	SOUT#939	SOUT#938	SOUT#937

51197	51196	51195	51194	51193	51192	51191	51190
SOUT#952	SOUT#951	SOUT#950	SOUT#949	SOUT#948	SOUT#947	SOUT#946	SOUT#945

51207	51206	51205	51204	51203	51202	51201	51200
SOUT#960	SOUT#959	SOUT#958	SOUT#957	SOUT#956	SOUT#955	SOUT#954	SOUT#953

51217	51216	51215	51214	51213	51212	51211	51210
SOUT#968	SOUT#967	SOUT#966	SOUT#965	SOUT#964	SOUT#963	SOUT#962	SOUT#961

51227	51226	51225	51224	51223	51222	51221	51220
SOUT#976	SOUT#975	SOUT#974	SOUT#973	SOUT#972	SOUT#971	SOUT#970	SOUT#969

51237	51236	51235	51234	51233	51232	51231	51230
SOUT#984	SOUT#983	SOUT#982	SOUT#981	SOUT#980	SOUT#979	SOUT#978	SOUT#977

51247	51246	51245	51244	51243	51242	51241	51240
SOUT#992	SOUT#991	SOUT#990	SOUT#989	SOUT#988	SOUT#987	SOUT#986	SOUT#985

51257	51256	51255	51254	51253	51252	51251	51250
SOUT#1000	SOUT#999	SOUT#998	SOUT#997	SOUT#996	SOUT#995	SOUT#994	SOUT#993

51267	51266	51265	51264	51263	51262	51261	51260
SOUT#1008	SOUT#1007	SOUT#1006	SOUT#1005	SOUT#1004	SOUT#1003	SOUT#1002	SOUT#1001

51277	51276	51275	51274	51273	51272	51271	51270
SOUT#1016	SOUT#1015	SOUT#1014	SOUT#1013	SOUT#1012	SOUT#1011	SOUT#1010	SOUT#1009

51287	51286	51285	51284	51283	51282	51281	51280
SOUT#1024	SOUT#1023	SOUT#1022	SOUT#1021	SOUT#1020	SOUT#1019	SOUT#1018	SOUT#1017

51297	51296	51295	51294	51293	51292	51291	51290
SOUT#1032	SOUT#1031	SOUT#1030	SOUT#1029	SOUT#1028	SOUT#1027	SOUT#1026	SOUT#1025

51307	51306	51305	51304	51303	51302	51301	51300
SOUT#1040	SOUT#1039	SOUT#1038	SOUT#1037	SOUT#1036	SOUT#1035	SOUT#1034	SOUT#1033

51317	51316	51315	51314	51313	51312	51311	51310
SOUT#1048	SOUT#1047	SOUT#1046	SOUT#1045	SOUT#1044	SOUT#1043	SOUT#1042	SOUT#1041

51327	51326	51325	51324	51323	51322	51321	51320
SOUT#1056	SOUT#1055	SOUT#1054	SOUT#1053	SOUT#1052	SOUT#1051	SOUT#1050	SOUT#1049

51337	51336	51335	51334	51333	51332	51331	51330
SOUT#1064	SOUT#1063	SOUT#1062	SOUT#1061	SOUT#1060	SOUT#1059	SOUT#1058	SOUT#1057

51347	51346	51345	51344	51343	51342	51341	51340
SOUT#1072	SOUT#1071	SOUT#1070	SOUT#1069	SOUT#1068	SOUT#1067	SOUT#1066	SOUT#1065

51357	51356	51355	51354	51353	51352	51351	51350
SOUT#1080	SOUT#1079	SOUT#1078	SOUT#1077	SOUT#1076	SOUT#1075	SOUT#1074	SOUT#1073

51367	51366	51365	51364	51363	51362	51361	51360
SOUT#1088	SOUT#1087	SOUT#1086	SOUT#1085	SOUT#1084	SOUT#1083	SOUT#1082	SOUT#1081

51377	51376	51375	51374	51373	51372	51371	51370
SOUT#1096	SOUT#1095	SOUT#1094	SOUT#1093	SOUT#1092	SOUT#1091	SOUT#1090	SOUT#1089

51387	51386	51385	51384	51383	51382	51381	51380
SOUT#1104	SOUT#1103	SOUT#1102	SOUT#1101	SOUT#1100	SOUT#1099	SOUT#1098	SOUT#1097

51397	51396	51395	51394	51393	51392	51391	51390
SOUT#1112	SOUT#1111	SOUT#1110	SOUT#1109	SOUT#1108	SOUT#1107	SOUT#1106	SOUT#1105

51407	51406	51405	51404	51403	51402	51401	51400
SOUT#1120	SOUT#1119	SOUT#1118	SOUT#1117	SOUT#1116	SOUT#1115	SOUT#1114	SOUT#1113
					ARITH ERROR FLAG	ARITH ZERO FLAG	ARITH CARRY FLAG

51417	51416	51415	51414	51413	51412	51411	51410
SOUT#1128	SOUT#1127	SOUT#1126	SOUT#1125	SOUT#1124	SOUT#1123	SOUT#1122	SOUT#1121

51427	51426	51425	51424	51423	51422	51421	51420
SOUT#1136	SOUT#1135	SOUT#1134	SOUT#1133	SOUT#1132	SOUT#1131	SOUT#1130	SOUT#1129

51437	51436	51435	51434	51433	51432	51431	51430
SOUT#1144	SOUT#1143	SOUT#1142	SOUT#1141	SOUT#1140	SOUT#1139	SOUT#1138	SOUT#1137

51447	51446	51445	51444	51443	51442	51441	51440
SOUT#1152	SOUT#1151	SOUT#1150	SOUT#1149	SOUT#1148	SOUT#1147	SOUT#1146	SOUT#1145

51457	51456	51455	51454	51453	51452	51451	51450
SOUT#1160	SOUT#1159	SOUT#1158	SOUT#1157	SOUT#1156	SOUT#1155	SOUT#1154	SOUT#1153

51467	51466	51465	51464	51463	51462	51461	51460
SOUT#1168	SOUT#1167	SOUT#1166	SOUT#1165	SOUT#1164	SOUT#1163	SOUT#1162	SOUT#1161

51477	51476	51475	51474	51473	51472	51471	51470
SOUT#1176	SOUT#1175	SOUT#1174	SOUT#1173	SOUT#1172	SOUT#1171	SOUT#1170	SOUT#1169

51487	51486	51485	51484	51483	51482	51481	51480
SOUT#1184	SOUT#1183	SOUT#1182	SOUT#1181	SOUT#1180	SOUT#1179	SOUT#1178	SOUT#1177

51497	51496	51495	51494	51493	51492	51491	51490
SOUT#1192	SOUT#1191	SOUT#1190	SOUT#1189	SOUT#1188	SOUT#1187	SOUT#1186	SOUT#1185

51507	51506	51505	51504	51503	51502	51501	51500
SOUT#1200	SOUT#1199	SOUT#1198	SOUT#1197	SOUT#1196	SOUT#1195	SOUT#1194	SOUT#1193

51517	51516	51515	51514	51513	51512	51511	51510
SOUT#1208	SOUT#1207	SOUT#1206	SOUT#1205	SOUT#1204	SOUT#1203	SOUT#1202	SOUT#1201

51527	51526	51525	51524	51523	51522	51521	51520
SOUT#1216	SOUT#1215	SOUT#1214	SOUT#1213	SOUT#1212	SOUT#1211	SOUT#1210	SOUT#1209

4.5 System Output Signals for Operations

4.5.1 Device 1

51537	51536	51535	51534	51533	51532	51531	51530
SOUT#1224	SOUT#1223	SOUT#1222	SOUT#1221	SOUT#1220	SOUT#1219	SOUT#1218	SOUT#1217
					INH WORK CONT:1	END WORK:1	START WORK:1

51547	51546	51545	51544	51543	51542	51541	51540
SOUT#1232	SOUT#1231	SOUT#1230	SOUT#1229	SOUT#1228	SOUT#1227	SOUT#1226	SOUT#1225

51557	51556	51555	51554	51553	51552	51551	51550
SOUT#1240	SOUT#1239	SOUT#1238	SOUT#1237	SOUT#1236	SOUT#1235	SOUT#1234	SOUT#1233

51567	51566	51565	51564	51563	51562	51561	51560
SOUT#1248	SOUT#1247	SOUT#1246	SOUT#1245	SOUT#1244	SOUT#1243	SOUT#1242	SOUT#1241

51577	51576	51575	51574	51573	51572	51571	51570
SOUT#1256	SOUT#1255	SOUT#1254	SOUT#1253	SOUT#1252	SOUT#1251	SOUT#1250	SOUT#1249

51587	51586	51585	51584	51583	51582	51581	51580
SOUT#1264	SOUT#1263	SOUT#1262	SOUT#1261	SOUT#1260	SOUT#1259	SOUT#1258	SOUT#1257

4.5.2 Device 2

51597	51596	51595	51594	51593	51592	51591	51590
SOUT#1272	SOUT#1271	SOUT#1270	SOUT#1269	SOUT#1268	SOUT#1267	SOUT#1266	SOUT#1265
					INHB WORK CONT:2	END WORK:2	START WORK:2

51607	51606	51605	51604	51603	51602	51601	51600
SOUT#1280	SOUT#1279	SOUT#1278	SOUT#1277	SOUT#1276	SOUT#1275	SOUT#1274	SOUT#1273

51617	51616	51615	51614	51613	51612	51611	51610
SOUT#1288	SOUT#1287	SOUT#1286	SOUT#1285	SOUT#1284	SOUT#1283	SOUT#1282	SOUT#1281

51627	51626	51625	51624	51623	51622	51621	51620
SOUT#1296	SOUT#1295	SOUT#1294	SOUT#1293	SOUT#1292	SOUT#1291	SOUT#1290	SOUT#1289

51637	51636	51635	51634	51633	51632	51631	51630
SOUT#1304	SOUT#1303	SOUT#1302	SOUT#1301	SOUT#1300	SOUT#1299	SOUT#1298	SOUT#1297

51647	51646	51645	51644	51643	51642	51641	51640
SOUT#1312	SOUT#1311	SOUT#1310	SOUT#1309	SOUT#1308	SOUT#1307	SOUT#1306	SOUT#1305

FS100	4	System I/O Signals
	4.6	Description of System Output Signals

4.6 Description of System Output Signals

The following symbols are used in the explanation to represent the signal conditions.



The signal takes effect while it is in the on state.



The rising edge is detected as the signal.

4.6.1 Alarm and Message Display

- **50010 to 50014: Alarm or Error Occurrence**



These signals indicate the occurrence of alarms or errors. The “MAJOR ALM OCCUR” (50010) signal remains ON until power is turned off.

- **Register M640 Alarm Code (Binary/BCD)**

If an alarm occurs in the system, the corresponding alarm code is output. If there are two or more alarms, the code of the first occurring alarm is output. To switch binary and BCD data type, use the parameter (S2C315). Factory setting is binary.

- **Register M641, 642 Alarm Data (Binary)**

This data is detailed information added to the alarm code.

- **50015, 50016: MEMORY or ENCDR BTRY WEAK**



These signals are turned ON to indicate that batteries need replacement when voltage drops in the memory protection battery and the absolute encoder memory retention battery. Loss of data in memory due to a weak battery causes much damage.

Take the signals as a kind of alarm and take appropriate action.

- **50017: COOLING FAN ERR**



This signal is turned ON to inform that the cooling fan is required to be changed when the CPU rack cooling fan inside FS100 or the cooling fan connected to the power on unit is not operating normally. Such an error as non-operating cooling fan causes damages to FS100 and robot components.

Take the signal as a kind of alarm and take appropriate action.

4.6.2 Mode and Cycle Selection and Particular Operation Setting

■ **50050 to 50052: Cycle Setting**



These signals indicate the status of specifications of current cycle setting. The signal corresponding to the selected cycle is turned on.

■ **50053 to 50054: Mode Setting**



These signals indicate the status of specifications of current mode settings. The signal corresponding to the selected mode is turned on.

■ **50055: SYSTEM RUNNING**



This signal tells the external device whether the controller is in the normal or error state. This signal is a pulse signal which turns on and off every 100 msec.

■ **50056: CMD REMOTE SET**



This signal indicates that the command remote function such as transmission is valid.

■ **50060: SPEED LIMIT**



This signal indicates that the manipulator is in the in-guard safe operation status.

■ **50061: DRY-RUN SET**



This signal indicates that the dry-run is set.

■ **50062: MACHINE-LOCK SET**



This signal indicates that the machine lock is set.

■ **50063: LIMIT OPEN SET**



This signal indicates that the soft limit is released. Switching to the play mode releases the soft limit automatically and turns off this signal.

■ **50064: CHECK-RUN SET**



This signal indicates the check run is set.

4.6.3 Start and Stop

■ **50020: TOP MASTER JOB**



This signal indicates that the execution position is at the head of the master job. The signal can be used as a check signal calling for master job.

■ **50066: POSITION CHECKED**



This signal indicates that the position check operation has been completed after “Alarm 4107: OUT OF RANGE (ABSO DATA)” occurred. The signal stays ON if the alarm does not occur after power ON.

■ **50067: FULL SPEED TEST**



This signal indicates that the manipulator is running in the condition that the safe speed limit is released.

■ **50070: RUN (Start Lamp)**



This signal indicates that the manipulator is running. That is, the manipulator is either executing jobs, ready for reserved starting, ready for multi-series starting, or performing test run. This signal is synchronized with the state of the “START” button on the programming pendant.

■ **50071: HOLD (Hold Lamp)**



This signal indicates that the manipulator is in the “HOLDING” status as “HOLD” being instructed. This signal is synchronized with the state of the “HOLD” button on the programming pendant.

■ **50073: SERVO ON**



This signal indicates that after the servo power is turned on, internal processing such as current position setting has been completed and the system is ready to accept “START” instruction. This can be used for determining external starting conditions.

■ **50074: I/O SIMULATED**



This signal indicates any of the signals that are in the simulation mode in the IO windows.

■ **50075: JOB EDIT INFORM**



This signal indicates that the job to be executed has just been edited, searched, or manipulated with the cursor on. This can be used for determining starting conditions after editing.

■ **50076: JOG OPN INFORM**



This signal indicates that the manipulator was made to move an axis or followed the FWD/BWD operation on the programming pendant. This signal goes OFF automatically when playback is started. This can be used for determining restarting condition.

■ **50077: OT RELEASE**



This signal indicates that the overrun status is released.

■ **50320 to 50321, 50330 to 50332: SERVO ON**



These signals indicate that the servo power for each robot/station is ON. With the signal ON, the corresponding servo power for each robot/station is ON.

■ **50360 to 50361: WAIT JOB SEQ**



These signals indicate that the manipulator is stopped by the "WAIT JOB SEQ" (40130 to 40131) signal. After accepting the above signal and the manipulator has stopped, these signals go ON. When sequence wait is cleared, these signals go OFF before the manipulator starts operating.

■ **50400 to 50401, 50410 to 50412: CONT JOB SEQ**



These signals indicate that manipulator operation is in executing state in the sequence of instruction as taught. These signals go ON when the initial job is executed after the power is turned on.

The same conditions as above are applied to the "FWD" and "TEST" operations on the programming pendant.

These signals go OFF in the following cases.

- When the cursor is moved by the operation such as change of the line No. with the programming pendant at the manipulator stop.
- When a different job is called up.
- When edit operation (insertion, modification, deletion) is executed from the programming pendant.

For a system with one manipulator, use signal No. 50400 (Robot 1 Job).

■ **50440 to 50441, 50450 to 50452: CTRL GRP RUN**



This signal indicates that the manipulator is running (segment data is not equal to 0)

■ **50490 to 50491: WORK PRMT RUN**



These signals indicate that the manipulator is running at the actual workable speed. These signals are synchronized with operations. The status of these signals during operations other than normal playback operation are shown below.

State 0: OFF 1: ON	Meaning
0	<ul style="list-style-type: none"> • Machine Lock Operation • Dry-Run Operation • Low-Speed Start-Up Operation
1	<ul style="list-style-type: none"> • During in-guard safety operation • During continuous operation with the programming pendant • When adjusting speed during operation • When speed is limited by the sensor

For a system with one manipulator, use signal No. 50490 (Robot 1 Job).

■ **50500 to 50501: SEARCHING**



These signals indicate that “SEARCH” instruction being executed. These signals can be used as effective sensing signals for external sensor.

For a system with one manipulator, use signal No. 50500 (Robot 1 Job).

■ **50520 to 50521: LOCUS DEVIATE**



These signals indicate that the corresponding manipulators are deviating from the natural locus, as jog operation after the emergency stop or motion stop.

For a system with one manipulator, use signal No. 50520 (Robot 1 Job).

■ **50690, 50691, 50692: Security Mode**



These signals indicate the current setting of security mode.

50690: Operation mode

50691: Editing mode

50692: Management mode

4.6.4 Interference Signals

- **50080 to 50157: CUBE/AXIS INTR**



These signals indicate the area in which the current control point is positioned, or in which the axis is positioned in the initially set area. Set the area by parameters (S2C003 to S2C194, S3C064 to S2C1087). These can be used to prevent interference with other manipulators or jigs.

4.6.5 Arithmetic Instruction Signals

- **51400, 51401, 51402: Arithmetic Flag**



These signals reflect the result of the arithmetic instruction in the following steps. There are three kinds of flag: ARITH CARRY FLAG (51400), ARITH ZERO FLAG (51401), and ARITH ERROR FLAG (51402).

4.6.6 Independent Control Signals (Optional)

- **50021 to 50025: TOP SUB (1 to 5) MASTER**



These signals indicate that the execution position is at the head of the master job in sub task 1 to 5. Use as a checking signal of master job in each sub task call.

- **50181: CRD WORK R1,R2**



This signal turns on when R1 and R2 are controlled in the same system.

- **50601 to 50605: SUB (1 to 5) HELD**



These signals indicate sub task 1 to 5 stops the operation by alarm occurrence or the "PAUSE" instruction. Operation can be restarted by pressing the [START] key on the programming pendant or inputting external start (40044).

These signals are turned off when all tasks stop or the sub task is released.

- **50621 to 50625: SUB ALARM OCCUR**



These signals indicate that the sub task is generating an alarm individually during the system section alarm occurrence (50012) or user section alarm occurrence (50013).

- **50640 to 50645: RUN (MASTER or SUB (1 to 5))**



These signals indicate that master or sub task (No. 1 to 5) is in execution.

- **50660 to 50665: HOLD (MASTER or SUB (1 to 5))**



These signals indicate that the robot is operating by sub task 1 to 5 and the master job signals.

- **50700 to 50705: SEL JOB (MASTER or SUB (1 to 5))**



This signal turns on when a job is selected.

■ **50725: OPEN DIALOG**



This signal turns on until “YES” or “NO” is selected in one of the following dialog boxes which appears when starting the job:

- “Start up from the edit cursor (black)?”
- “Start up from the current position?”
- “Start up in the middle of I/O simulation?”
- “Start up in the middle of overriding?”

■ **50726: MOTOR TEMP HIGH**



This signal turns on if the temperature of the encoder rises to 85°C or higher.

■ **50727: ENERGY SAVING**



This signal turns on during the energy saving mode.

■ **50776: A.BACKUP DATA MK**



This signal indicates that the data is being automatically backed up. The servo power cannot be turned on while this signal is on.

■ **50777: A.BACKUP DATA TR**



This signal turns on from the occurrence of backup request until the completion of data transmission to the CompactFlash card in the programming pendant.

■ **50900: I/O TRACE MODE**



This signal indicates that the I/O is being traced.

4.6.7 Signals for Servo Float Function (Optional)

- **50510 to 50511: SERVOFLOAT ON**



These signals indicate the servo float operating status.

In the system with one manipulator, use signal No. 50510 (R1).

- **50560 to 50561: SHOCK DTCT ON**



This signal indicates that the shock detection function is valid.

- **50697: SHOCK DTCT ALM**



This signal indicates that the shock detection alarm “4315: SHOCK DETECTION” currently occurs.

4.6.8 Signals for Operations

Signals from 51530 to 51647 are classified into two blocks and assigned to output signals that have different meanings depending on the application.

- **51530, 51590: START WORK**



These signals indicate work starting and wait for inputting of the “START WORK ANS” (41130, 41190) signal.

For a system with one manipulator, use signal No. 51530.

- **51531, 51591: END WORK**



These signals indicate work ending and wait for inputting of the “END WORK ANS” (41131, 41191) signal.

For a system with one manipulator, use signal No. 51531.

- **51532, 51592: INHB WORK CONT**



These signals indicate whether to continue the operation when resuming, after stopping a while at the operation. When the signals are ON, the operation is not continued.

For a system with one manipulator, use signal No. 51532.

5 Auxiliary Relay Signals

The internal signals used in the standard ladder are shown below.

70017	70016	70015	70014	70013	70012	70011	70010
CONTROL POWER ON COMPLETED (NORMALITY ON)	SYSTEM RESERVE	SYSTEM RESERVE				EXT START RECEIVING READY	EXT START

70027	70026	70025	70024	70023	70022	70021	70020
		REMOTE SELECT				WAIT UNTIL INTRFRNC OFF	ALARM OCCUR

70037	70036	70035	70034	70033	70032	70031	70030
IN CUBE 4	IN CUBE 3	IN CUBE 2	IN CUBE 1	INTRF 4 ENTRANCE PROHIBIT	INTRF 3 ENTRANCE PROHIBIT	INTRF 2 ENTRANCE PROHIBIT	INTRF 1 ENTRANCE PROHIBIT

70047	70046	70045	70044	70043	70042	70041	70040
				WORK PROHIBIT	WORK INSTRUCTION CONTINUE PROHIBIT	WORK OPERATING	WORK INSTRUCTION

70057	70056	70055	70054	70053	70052	70051	70050

⋮

79997	79996	79995	79994	79993	79992	79991	79990

<Example 1> INTRF 1 ENTRANCE PROHIBIT

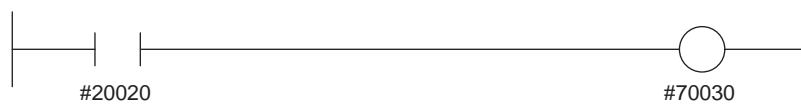

<Example 2> IN CUBE 1

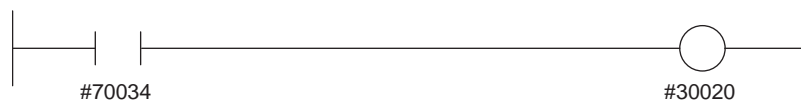

6 Internal Control Status Signals

6.1 List of Internal Control Status Signals

* : NC contact

80017	80016	80015	80014	80013	80012	80011	80010
SVON	START	HOLD		TEACH	PLAY	REMOTE	

REMOTE Remote Mode Select
 PLAY Play Mode Select
 TEACH Teach Mode Select
 *HOLD Hold (Programming Pendant)
 START Operation Start (Programming Pendant)
 SVON Servo On (Programming Pendant)

80027	80026	80025	80024	80023	80022	80021	80020
PBESP	PPESP	EXESP	ERRCPU	SAFF	TEACH	TEACH_LOCK	PM

PM Play Mode
 TEACH_LOCK Teach Lock
 TEACH Teach Mode
 *SAFF Safety Plug Input
 *ERRCPU Main CPU Error (Emergency Stop)
 *EXESP External Emergency Stop
 *PPESP Programming Pendant Emergency Stop
 *PBESP FS100 Controller Emergency Stop

80037	80036	80035	80034	80033	80032	80031	80030
			DSW	SVCNRDY1		SVONRDY0	

SVON RDY0 Servo ON Condition 1
 SVON RDY1 Servo ON Condition 2
 DSW Enable Switch Input

FS100	6	Internal Control Status Signals
	6.1	List of Internal Control Status Signals

80047	80046	80045	80044	80043	80042	80041	80040
FST	SSP					SAFSPD1	SAFSPD2

SAFSPD2 Safe Speed 2
SAFSPD1 Safe Speed 1
SSP Safe Speed Mode Select
FST Full-speed Test

80057	80056	80055	80054	80053	80052	80051	80050
				SVON_KEEP	SVKPEN		

SVKPEN Servo On Status Enabled
SVON_KEEP Servo On Keep Enabled

80067	80066	80065	80064	80063	80062	80061	80060
OT						PROTECTED_STOP	

*PROTECTED_STOP Protection Stop
*OT Over Travel

80087	80086	80085	80084	80083	80082	80081	80080
		AXDIN6	AXDIN5	AXDIN4	AXDIN3	AXDIN2	AXDIN1

AXDIN1 (RIN1) Direct In (Servo) 1
AXDIN2 (RIN2) Direct In (Servo) 2
AXDIN3 (RIN3) Direct In (Servo) 3
AXDIN4 (RIN4) Direct In (Servo) 4
AXDIN5 (RIN5) Direct In (Servo) 5
AXDIN6 (RIN6) Direct In (Servo) 6

80097	80096	80095	80094	80093	80092	80091	80090
		AXDIN6	AXDIN5	AXDIN4	AXDIN3	AXDIN2	AXDIN1

AXDIN1 (RIN1) Direct In (Servo2) 1
 AXDIN2 (RIN2) Direct In (Servo2) 2
 AXDIN3 (RIN3) Direct In (Servo2) 3
 AXDIN4 (RIN4) Direct In (Servo2) 4
 AXDIN5 (RIN5) Direct In (Servo2) 5
 AXDIN6 (RIN6) Direct In (Servo2) 6

80107	80106	80105	80104	80103	80102	80101	80100

80117	80116	80115	80114	80113	80112	80111	80110

80127	80126	80125	80124	80123	80122	80121	80120

80137	80136	80135	80134	80133	80132	80131	80130

80147	80146	80145	80144	80143	80142	80141	80140

80157	80156	80155	80154	80153	80152	80151	80150

80187	80186	80185	80184	80183	80182	80181	80180
						*OT (MACHINE SAFETY MODULE)	*OT (MACHINE SAFETY MODULE)

*OT (MACHINE SAFETY MODULE) Over Travel (machine safety OT1)
 *OT (MACHINE SAFETY MODULE) Over Travel (machine safety OT2)

80247	80246	80245	80244	80243	80242	80241	80240
						*PROTECTED_STOP	*PROTECTED_STOP

*PROTECTED_STOP Protection Stop

*PROTECTED_STOP Protection Stop

80287	80286	80285	80284	80283	80282	80281	80280
						*FANALM1	*FANALM1

*FANALM1 Fan Alarm 1

*FANALM1 Fan Alarm 1

80297	80296	80295	80294	80293	80292	80291	80290
						*FANALM2	*FANALM2

*FANALM2 Fan Alarm 2

*FANALM2 Fan Alarm 2

80327	80326	80325	80324	80323	80322	80321	80320

:
:

80637	80636	80635	80634	80633	80632	80631	80630

The following symbols are used in the explanation to represent the signal conditions.



The signal takes effect while it is in the on state.



The rising edge is detected as the signal.

6.1.1 Description of Internal Control Status Signals (Monitor)

■ **80011 to 80013: MODE SELECTION**



These signals indicate the status of the mode key of the programming pendant.

■ **80015: *PROGRAMMING PENDANT PANEL HOLD**



These signals indicate the status of the mode key of the programming pendant.

■ **80016: OPERATION START**



This signal indicates the operating status of the [START] key on the programming pendant.

■ **80017: SERVO POWER ON**



This signal indicates the operating status of the [SERVO POWER] key on the programming pendant.

■ **80020: PM**



This signal turns on during the play mode.

■ **80021: TEACH_LOCK**



This signal turns on while DSW is being pressed in the teach mode.

■ **80022: TEACH**



This signal turns on during the teach mode.

■ **80023: *SAFETY PLUG INPUT**



This signal turns off when the safety guard input signal, connected to the robot system signal connector, operates.

For the connection, refer to “13.2.2.2 Connection for Safeguarding (Safety Plug) (SAFF) Signal” of the FS100 Instructions.

■ **80024: MAIN CPU ERROR**



This signal turns off when the servo turns off in the system (MAIN CPU).

■ **80025: *EXTERNAL EMERGENCY STOP**



This signal turns off when the emergency stop signal, connected to the robot system signal connector, operates.

For the connection, refer to the “13.2.2.3 Connection for External Emergency Stop (EXESP) Signal” of the FS100 Instructions.

■ **80026: *PROGRAMMING PENDANT EMERGENCY STOP**



This signal turns off when the emergency stop on the programming pendant operates.

■ **80027: * FS100 PANEL EMERGENCY STOP**



This signal turns off when the emergency stop on the FS100 (optional) operates.

■ **80031: SERVO ON CONDITION 1**



This signal turns on when the following signals satisfy the conditions for servo ON status.

When this signal turns off while the servo is ON, the servo power supply is shut down.

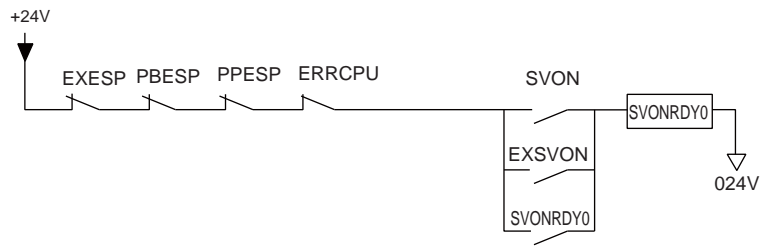

■ **80033: SERVO ON CONDITION 2**



This signal turns on when the following signals satisfy the conditions for servo ON status.

When this signal turns off while the servo is ON, the servo power supply is shut down.

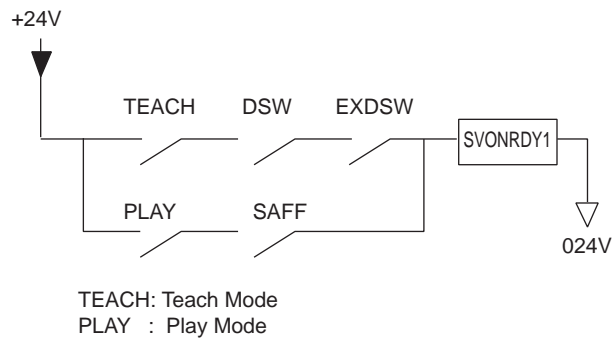

■ **80034: ENABLE SWITCH INPUT**



This signal indicates the operating status of enable switch input signal.

This signal turns on by holding the enable switch and turns off by holding longer until it clicks.

■ **80040: SAFE SPEED 2**



This signal turns on in the safe speed 2 condition.

■ **80041: SAFE SPEED 1**



This signal turns on in the safe speed 1 condition.

- **80046: SAFE SPEED MODE SELECT**



This signal turns on either in the safe speed 1 or the safe speed 2 condition.

- **80047: FULL-SPEED TEST**



This signal turns on when the safe speed limit is released.

- **80052: SVKPEN**



This signal indicates the servo on status enabled.

- **80053: SVON_KEEP**



This signal turns on during the servo on ready status.

- **80061: *PROTECTED_STOP**



This signal indicates the detecting status of protection stop.

This signal is input from the machine safety module.

- **80067: *OVERTRAVEL**



This signal turns off when the robot axis overrun LS operates.

- **80080 to 80085, 80090 to 80095: DIRECT IN (SERVO) 1 to 6**



These signals indicate the status of direct in (servo) input signals.

The signals are input from the specific input terminal block.

- **80180, 80181**



These signals are individual monitoring signals for overtravel (machine safety module).

- **80240, 80241**



These signals are individual monitoring signals for protection stop (PROTECTED_STOP).

If any of 80240 through 80241 is 0 (protection stop), 80061 becomes 0.

- **80280, 80281**



These signals are individual monitoring signals for the cooling fan error 1 (*FANALM1).

- **80290, 80291**



These signals are individual monitoring signals for the cooling fan error 2 (*FANALM2).

7 Pseudo Input Signals

The following symbols are used in the explanation to represent the signal conditions.



The signal takes effect while it is in the on state.



The rising edge is detected as the signal.

7.1 Description of Pseudo Input Signals

- **82011: EXT HOLD ENABLE**



Enables or disables the external hold signal.

0: Disabled 1: Enabled

- **82014 to 82016: REMOTE FUNCTION SELECTION**



The pseudo input signal window allows to set whether the I/O, commands, or programming pendant is used at the remote mode selection.

These signals indicate the status set in the pseudo input signal window as shown below.

(0:OFF 1:ON)

82014	IO	0:Used	1:Not Used
82015	Command	0:Not Used	1:Used
82016	Programming Pendant	0:Used	1:Not Used

8 Network I/O Signals

Network input signals are related to optional network functions. For the detailed information, refer to the operator's manual regarding each network function.

9 Interface Panel Signals

Interface panel signals are related to the optional interface panel functions. For details, refer to "FS100 OPTIONS INSTRUCTIONS FOR INTERFACE PANEL FUNCTION".

10 I/O Signals Except Concurrent I/O

The following signal is connected directly to the manipulator control section without passing through the concurrent I/O.

Adequate care should be taken for switch setting and method of connection when using this signal.

10.1 Description

- **EXESP: FOR EXTERNAL EMERGENCY STOP**



This signal allows to use the emergency stop switch of an external operation equipment.

When this signal is input, the servo power goes OFF, and the job execution is stopped.

The servo power cannot be turned on while this signal is being input.

This function becomes invalid by connecting the jumper wire.

- **SAFF: FOR SAFETY PLUG**



This signal turns off the servo power when the door of the safeguard is open.

Connect interlock signals such as a safety plug installed in the safeguard door. Install an interlock signal such as safety plugs in door of the safeguard.

When the interlock signal is input, the servo power goes OFF, and the servo power cannot be turned on.

However, this signal is invalid in the teach mode.

- **AXDIN1 to 6: FOR DIRECT IN (SERVO) INPUT SIGNAL 1 to 6**



This signal can be used in conjunction with the search function.

- **PSTOP: FOR PROTECTION STOP SIGNAL**



When the servo power is on, this signal is used to immediately turn off the servo power for safety protection.

- **ESPOUT: FOR EMERGENCY STOP OUTPUT SIGNAL**



This signal outputs the signal status of the programming pendant emergency stop, the external emergency stop, and the safeguarding (safety plug) in the automatic operation mode, as dual signals to the external device.

This signal can be used to check the signal status of the programming pendant emergency stop, the external emergency stop, and the safeguarding (safety plug) in the automatic operation mode, by using an external safety device, etc.

11 Registers

11.1 Common Registers

11.1.1 Common User Registers

M009	M008	M007	M006	M005	M004	M003	M002	M001	M000
M019	M018	M017	M016	M015	M014	M013	M012	M011	M010
M029	M028	M027	M026	M025	M024	M023	M022	M021	M020
M039	M038	M037	M036	M035	M034	M033	M032	M031	M030
M049	M048	M047	M046	M045	M044	M043	M042	M041	M040
M059	M058	M057	M056	M055	M054	M053	M052	M051	M050
M069	M068	M067	M066	M065	M064	M063	M062	M061	M060
M079	M078	M077	M076	M075	M074	M073	M072	M071	M070
M089	M088	M087	M086	M085	M084	M083	M082	M081	M080
M099	M098	M097	M096	M095	M094	M093	M092	M091	M090
M109	M108	M107	M106	M105	M104	M103	M102	M101	M100
M369	M368	M367	M366	M365	M364	M363	M362	M361	M360
								PROCESS2 ON	PROCESS1 ON
M379	M378	M377	M376	M375	M374	M373	M372	M371	M370
								PROCESS2 STROKE	PROCESS1 STROKE
M389	M388	M387	M386	M385	M384	M383	M382	M381	M380
		IO ALARM DETECT (113 to 128)	IO ALARM DETECT (97 to 112)	IO ALARM DETECT (81 to 96)	IO ALARM DETECT (65 to 80)	IO ALARM DETECT (49 to 64)	IO ALARM DETECT (33 to 48)	IO ALARM DETECT (17 to 32)	IO ALARM DETECT (1 to 16)
M399	M398	M397	M396	M395	M394	M393	M392	M391	M390
		IO MESSAGE DETECT (113 to 128)	IO MESSAGE DETECT (97 to 112)	IO MESSAGE DETECT (81 to 96)	IO MESSAGE DETECT (65 to 80)	IO MESSAGE DETECT (49 to 64)	IO MESSAGE DETECT (33 to 48)	IO MESSAGE DETECT (17 to 32)	IO MESSAGE DETECT (1 to 16)

M569	M568	M567	M566	M565	M564	M563	M562	M561	M560
ANALOG OUTPUT									
10	9	8	7	6	5	4	3	2	1

M579	M578	M577	M576	M575	M574	M573	M572	M571	M570
ANALOG OUTPUT									
20	19	18	17	16	15	14	13	12	11

M589	M588	M587	M586	M585	M584	M583	M582	M581	M580
ANALOG OUTPUT									
30	29	28	27	26	25	24	23	22	21

M599	M598	M597	M596	M595	M594	M593	M592	M591	M590
ANALOG OUTPUT									
40	39	38	37	36	35	34	33	32	31

11.1.2 Common System Registers

M609	M608	M607	M606	M605	M604	M603	M602	M601	M600
ANALOG INPUT									
10	9	8	7	6	5	4	3	2	1
M619	M618	M617	M616	M615	M614	M613	M612	M611	M610
ANALOG INPUT									
20	19	18	17	16	15	14	13	12	11
M629	M629	M628	M627	M626	M625	M624	M623	M622	M620
ANALOG INPUT									
30	29	28	27	26	25	24	23	22	21
M639	M638	M637	M636	M635	M634	M633	M632	M631	M630
ANALOG INPUT									
40	39	38	37	36	35	34	33	32	31
M649	M648	M647	M646	M645	M644	M643	M642	M641	M640
			ERROR DATA H	ERROR DATA L	ERROR CODE	ALARM DATA TYPE	ALARM DATA H	ALARM DATA L	ALARM CODE
M659	M658	M657	M656	M655	M654	M653	M652	M651	M650
M669	M668	M667	M666	M665	M664	M663	M662	M661	M660
M679	M678	M677	M676	M675	M674	M673	M672	M671	M670
M689	M688	M687	M686	M685	M684	M683	M682	M681	M680
M699	M698	M697	M696	M695	M694	M693	M692	M691	M690
M709	M708	M707	M706	M705	M704	M703	M702	M701	M700
M719	M718	M717	M716	M715	M714	M713	M712	M711	M710
M729	M728	M727	M726	M725	M724	M723	M722	M721	M720
⋮									
M919	M918	M917	M916	M915	M914	M913	M912	M911	M910

11.2 Registers for Operations

Device 2

M469	M468	M467	M466	M465	M464	M463	M462	M461	M460

Device 1

M479	M478	M477	M476	M475	M474	M473	M472	M471	M470
SYSTEM RESERVE									

Device 2

M549	M548	M547	M546	M545	M544	M543	M542	M541	M540

Device 1

M559	M558	M557	M556	M555	M554	M553	M552	M551	M550

Device 1

M929	M928	M927	M926	M925	M924	M923	M922	M921	M920

Device 2

M939	M938	M937	M936	M935	M934	M933	M932	M931	M930

12 Standard Ladder Programs

12.1 List of Usable Instructions

The following table shows a list of usable instructions in concurrent I/O.



In the instruction, there are two kinds of instructions, the one which uses the memory of one step and the other which uses the memory of two steps.

Table 12-1: List of Usable Instructions in Concurrent I/O (Sheet 1 of 6)

Instruction	Symbol	Function	Format	Remarks
STR		Logic line starting Temporary storing of intermediate result in logical operation Relay No. #XXXXX	STR #XXXXX	1 Step Instruction
STR-NOT		NC contact used to start the logic line Temporary storing of intermediate result in logical operation Relay No. #XXXXX	STR-NOT #XXXXX	1 Step Instruction
AND		Logical AND Relay No. #XXXXX	AND #XXXXX	1 Step Instruction
AND-NOT		Logical AND negation Relay No. #XXXXX	AND-NOT #XXXXX	1 Step Instruction
OR		Logical OR Relay No. #XXXXX	OR #XXXXX	1 Step Instruction
OR-NOT		Logical OR negation Relay No. #XXXXX	OR-NOT #XXXXX	1 Step Instruction
AND-STR		Logical AND for intermediate are result	AND-STR	1 Step Instruction
OR-STR		Logical OR for intermediate are result	OR-STR	1 Step Instruction
OUT		External or internal output Relay No. #XXXXX	OUT #XXXXX	1 Step Instruction
PART		User/System Identification (Not displayed on the programming pendant)	PART N	1 Step Instruction
END		Program end (Not displayed on the programming pendant)	END	1 Step Instruction
TMR		ON-delay time (100 ms) Set Value (S) • Decimal (0-65535) • Register (M000-M999) Curr value (D) • Register (M000-M559)	TMR D,S	2 Steps Instruction

Table 12-1: List of Usable Instructions in Concurrent I/O (Sheet 2 of 6)

Instruction	Symbol	Function	Format	Remarks
CNT		Subtract counter Set value (S) • Decimal (0-65535) • Register (M000-M999) Curr value (D) • Register (M000-M559)	CNT D,S	2 Steps Instruction
GSTR		Transmission of batch contents of 1 group (8 bits) Relay No. #XXXX0	GSTR #XXXX0	1 Step Instruction
GOUT			GOUT #XXXX0	1 Step Instruction
PLS		Rising up pulse output Relay No. #XXXXX	PLS #XXXXX	1 Step Instruction Exe Condition
PLF		Rising down pulse output Relay No. #XXXXX	PLF #XXXXX	1 Step Instruction Exe Condition
ADD	<p>$D \leftarrow S1 + S2$ Arith Flag: Carry=0/1 ; Zero=0/1 ; (Error=0)</p>	Add 16 bits unsigned binary data (0-65535) S1, S2: Source • Decimal (0-65535) • Register (M000-M999) D: Destination • Register (M000-M599)	ADD S1,S2,D	2 Steps Instruction Exe Condition
SUB	<p>$D \leftarrow S1 - S2$ Arith Flag: Carry=0/1 ; Zero=0/1 ; (Error=0)</p>	Subtract 16 bits unsigned binary data (0-65535) S1, S2: Source • Decimal (0-65535) • Register (M000-M999) D: Destination • Register (M000-M599)	SUB S1,S2,D	2 Steps Instruction Exe Condition
MUL	<p>$D_{n+1}, D_n \leftarrow S1 \times S2$ Arith Flag: (Carry=0) ; (Zero=0) ; (Error=0)</p>	Multiply 16 bits unsigned binary data (0-65535) S1, S2: Source • Decimal (0-65535) • Register (M000-M999) D _n , D _{n+1} : Destination D _n : Low data storing register D _{n+1} : High data storing register • Register (M000-M599)	MUL S1,S2,D	2 Steps Instruction Exe Condition

Table 12-1: List of Usable Instructions in Concurrent I/O (Sheet 3 of 6)







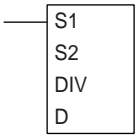

Instruction	Symbol	Function	Format	Remarks
DIV	 <p>D(Quotient)\leftarrowS1/S2 Arith Flag: (Carry=0) ; (Zero=0) ; Error=0/1</p>	Divide 16 bits unsigned binary data (0-65535) S1, S2: Source • Decimal (0-65535) • Register (M000-M999) D: Destination • Register (M000-M599)	DIV S1,S2,D	2 Steps Instruction Exe Condition 
MOD	 <p>D(Modulus)\leftarrowS1/S2 Arith Flag: (Carry=0) ; (Zero=0) ; Error=0/1</p>	Modules of 16 bits unsigned binary data (0-65535) S1, S2: Source • Decimal (0-65535) • Register (M000-M999) D: Destination • Register (M000-M599)	MOD S1,S2,D	2 Steps Instruction Exe Condition 
BIN	 <p>D\leftarrowS Arith Flag: Carry=0/1 ; (Zero=0) ; Error=0/1</p>	Convert 8/16 bits data from BCD to BIN S: Source • Register (M000-M999) • Relay No. (byte) #XXXX0 • Relay No. (word) W#XXXX0 D: Destination • Register (M000-M599) • Relay No. (byte) #XXXX0 • Relay No. (word) W#XXXX0	BIN S,D	2 Steps Instruction Exe Condition 
BCD	 <p>D\leftarrowS Arith Flag: Carry=0/1 ; (Zero=0) ; Error=0/1</p>	Convert 8/16 bits data from BIN to BCD S: Source • Register (M000-M599) • Relay No. (byte) #XXXX0 • Relay No. (word) W#XXXX0 D: Destination • Register (M000-M599) • Relay No. (byte) #XXXX0 • Relay No. (word) W#XXXX0	BCD S,D	2 Steps Instruction Exe Condition 
MOV	 <p>D\leftarrowS</p>	Transmit 8/16 bits data S: Source • Decimal (0-65535) • Register (M000-M999) • Relay No. (byte) #XXXX0 • Relay No. (word) W#XXXX0 D: Destination • Register (M000-M599) • Relay No. (byte) #XXXX0 • Relay No. (word) W#XXXX0	MOV S,D	2 Steps Instruction Exe Condition 

Table 12-1: List of Usable Instructions in Concurrent I/O (Sheet 4 of 6)

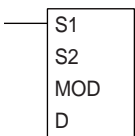

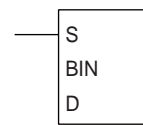
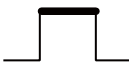
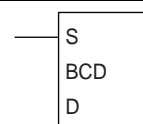

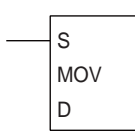



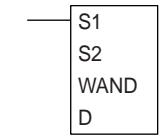

Instruction	Symbol	Function	Format	Remarks
WAND	 <p>$D \leftarrow S1 \cap S2$</p>	Logical AND of 8/16 bits data S1, S2: Source <ul style="list-style-type: none"> • Decimal (0-65535) • Register (M000-M999) • Relay No. (byte) #XXXX0 • Relay No. (word) W#XXXX0 D: Destination <ul style="list-style-type: none"> • Register (M000-M599) • Relay No. (byte) #XXXX0 • Relay No. (word) W#XXXX0 	WAND S1,S2,D	2 Steps Instruction Exe Condition 
WOR	 <p>$D \leftarrow S1 \cup S2$</p>	Logical OR of 8/16 bits data S1, S2: Source <ul style="list-style-type: none"> • Decimal (0-65535) • Register (M000-M999) • Relay No. (byte) #XXXX0 • Relay No. (word) W#XXXX0 D: Destination <ul style="list-style-type: none"> • Register (M000-M599) • Relay No. (byte) #XXXX0 • Relay No. (word) W#XXXX0 	WOR S1,S2,D	2 Steps Instruction Exe Condition 
WXOR	 <p>$D \leftarrow (S1 \cup S2) \cap \overline{(S1 \cap S2)}$</p>	Exclusive OR of 8/16 bits data S1, S2: Source <ul style="list-style-type: none"> • Decimal (0-65535) • Register (M000-M999) • Relay No. (byte) #XXXX0 • Relay No. (word) W#XXXX0 D: Destination <ul style="list-style-type: none"> • Register (M000-M599) • Relay No. (byte) #XXXX0 • Relay No. (word) W#XXXX0 	WXOR S1,S2,D	2 Steps Instruction Exe Condition 
WNOT	 <p>$D \leftarrow \overline{S}$</p>	Logical NOT of 8/16 bits data S: Source <ul style="list-style-type: none"> • Decimal (0-65535) • Register (M000-M999) • Relay No. (byte) #XXXX0 • Relay No. (word) W#XXXX0 D: Destination <ul style="list-style-type: none"> • Register (M000-M599) • Relay No. (byte) #XXXX0 • Relay No. (word) W#XXXX0 	WNOT S,D	2 Steps Instruction Exe Condition 

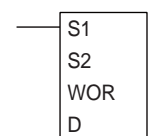
Table 12-1: List of Usable Instructions in Concurrent I/O (Sheet 5 of 6)

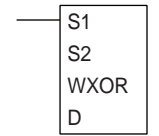
Instruction	Symbol	Function	Format	Remarks
SHL	<p>Arith Flag: Carry=0/1 ; (Zero=0) ; (Error=0)</p>	<p>Left shift of 8/16 bits data S: Source • Decimal (0-65535) • Register (M000-M999) • Relay No. (byte) #XXXX0 • Relay No. (word) W#XXXX0 n: Shift count • Decimal (0-16) D: Destination • Register (M000-M599) • Relay No. (byte) #XXXX0 • Relay No. (word) W#XXXX0</p>	SHL S,n,D	<p>2 Steps Instruction</p> <p>Exe Condition</p>
SHR	<p>Arith Flag: Carry=0/1 ; (Zero=0) ; (Error=0)</p>	<p>Right shift of 8/16 bits data S: Source • Decimal (0-65535) • Register (M000-M999) • Relay No. (byte) #XXXX0 • Relay No. (word) W#XXXX0 n: Shift count • Decimal (0-16) D: Destination • Register (M000-M599) • Relay No. (byte) #XXXX0 • Relay No. (word) W#XXXX0</p>	SHR S,n,D	<p>2 Steps Instruction</p> <p>Exe Condition</p>
ROL	<p>(Note) Carry flag is not included in rotation. Arith Flag: Carry=0/1 ; (Zero=0) ; (Error=0)</p>	<p>Left rotation of 8/16 bits data S: Source • Decimal (0-65535) • Register (M000-M999) • Relay No. (byte) #XXXX0 • Relay No. (word) W#XXXX0 n: Rotation count • Decimal (0-16) D: Destination • Register (M000-M599) • Relay No. (byte) #XXXX0 • Relay No. (word) W#XXXX0</p>	ROL S,n,D	<p>2 Steps Instruction</p> <p>Exe Condition</p>

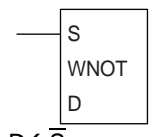
Table 12-1: List of Usable Instructions in Concurrent I/O (Sheet 6 of 6)

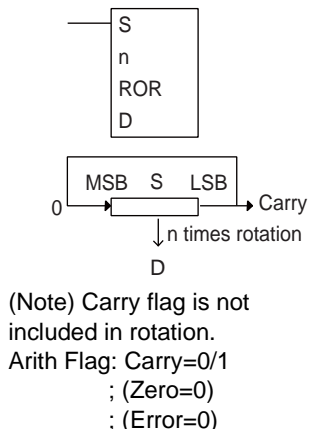
Instruction	Symbol	Function	Format	Remarks
ROR		Right rotation of 8/16 bits data S: Source • Decimal (0-65535) • Register (M000-M999) • Relay No. (byte) #XXXX0 • Relay No. (word) W#XXXX0 n: Rotation count • Decimal (0-16) D: Destination • Register (M000-M599) • Relay No. (byte) #XXXX0 • Relay No. (word) W#XXXX0	ROR S,n,D	2 Steps Instruction Exe Condition 
MLTMR		ON-delay time (1 ms) Set Value (S) • Decimal (0-65535) • Register (M000-M999) Curr value (D) • Register (M000-M559)	MLTMR D, S	2 Steps Instruction

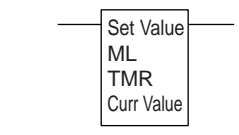
#XXXXX: Relay No., MXXX: Register Number, YYYY: Numerical Value (0-65535), N: Numerical Value (1-2)

12.2 Description of Concurrent I/O Instructions

NOTE

- The output cannot be done to the same relay multiple times.
- The numbers of the output relays are limited to 0XXXX, 3XXXX, 4XXXX, and 7XXXX.
- Up to 560 TMR/CNT/MLTMR instructions and operation instructions which can use registers can be registered.
- The registers used as current values of TMR/CNT/MLTMR instructions cannot be output multiple times. However, the registers used as the destination registers of arithmetic instructions can be output multiple times.

12.2.1 STR Instruction

1. Format
STR #XXXXX
#XXXXX: Relay No.
2. Function
Operates as a Normal Open at the beginning of logical line.
Stores temporarily the preliminary result of the logic operation.
3. Ladder Program Example

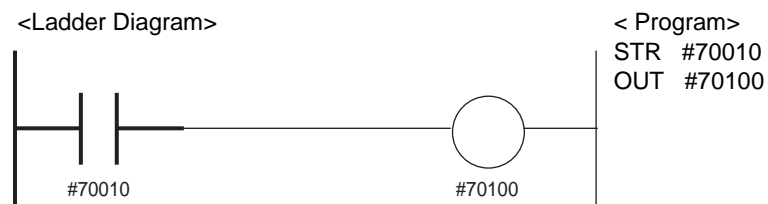

12.2.2 STR-NOT Instruction

1. Format
STR-NOT #XXXXX
#XXXXX: Relay No.
2. Function
Operates as a Normal Close at the beginning of logical line.
Stores temporarily the preliminary result of the logic operation.
3. Ladder Program Example

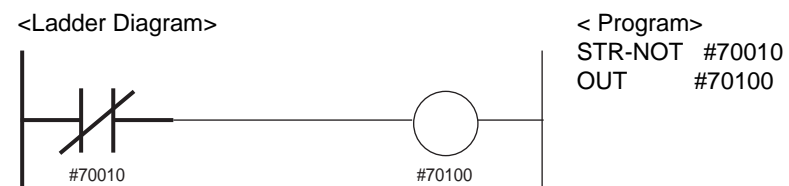

12.2.3 AND Instruction

1. Format
 AND #XXXXX
 #XXXXX: Relay No.
2. Function
 Performs logical AND operation.
3. Ladder Program Example

<Ladder Diagram>



< Program >

```
STR #70010
AND #70011
OUT #70100
```

12.2.4 AND-NOT Instruction

1. Format
 AND-NOT #XXXXX
 #XXXXX: Relay No.
2. Function
 Performs logical AND negation operation.
3. Ladder Program Example

<Ladder Diagram>



< Program >

```
STR #70010
AND-NOT #70011
OUT #70100
```

12.2.5 OR Instruction

1. Format
 OR #XXXXX
 #XXXXX: Relay No.
2. Function
 Performs logical OR operation.
3. Ladder Program Example

<Ladder Diagram>

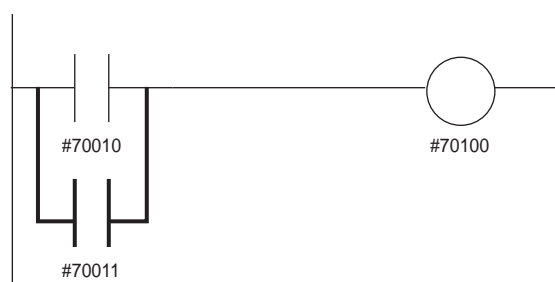

< Program >

```
STR #70010
OR #70011
OUT #70100
```

12.2.6 OR-NOT Instruction

1. Format
 OR-NOT #XXXXX
 #XXXXX: Relay No.
2. Function
 Performs logical OR negation operation.
3. Ladder Program Example

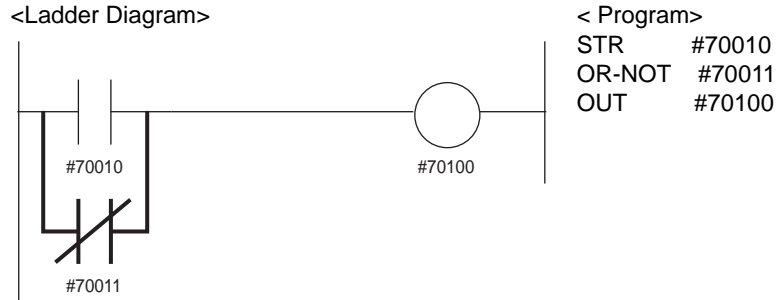

12.2.7 AND-STR Instruction

1. Format
 AND-STR
2. Function
 Performs logical AND operation with the preliminary results.
3. Ladder Program Example

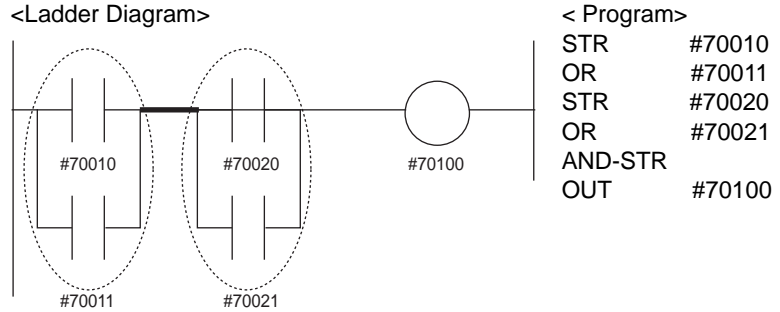

12.2.8 OR-STR Instruction

1. Format
 OR-STR
2. Function
 Performs logical OR operation with the preliminary results.
3. Ladder Program Example

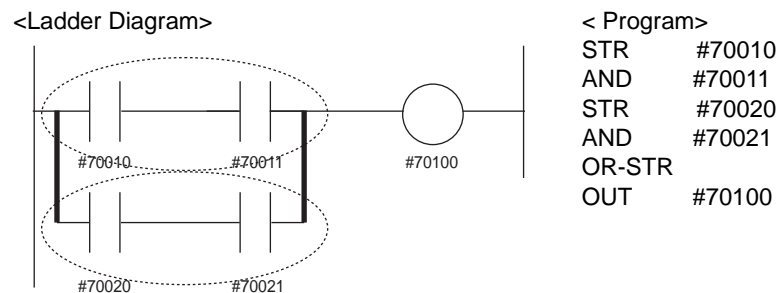

12.2.9 OUT Instruction

1. Format
 OUT #XXXXX
 #XXXXX: Relay No.
2. Function
 Outputs to the internal or the external.
3. Ladder Program Example

NOTE This instruction cannot be output multiple times to one relay.

<Ladder Diagram>

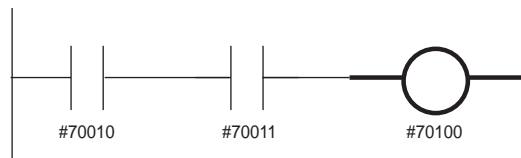

< Program >

```
STR    #70010
AND    #70011
OUT    #70100
```

12.2.10 PART Instruction

1. Format
 PART N
 N: Ladder Identification Number (1: System Ladder, 2: User Ladder)
2. Function
 Identifies the system ladder from the user ladder.
3. Ladder Program Example

NOTE This instruction is not displayed in the programming pendant screen.

<Ladder Diagram>

There is no symbol.

System

User

< Program >

```
PART  1
STR    #70010
OUT    #70100
:
PART  2
:
END
```

12.2.11 END Instruction

1. Format
END
2. Function
Ends the ladder program.
3. Ladder Program Example



This instruction is not displayed in the programming pendant screen.

<Ladder Diagram>

There is no symbol.

< Program>

```
STR    #70010  
OUT    #70100  
END
```

12.2.12 TMR Instruction

1. Format

TMR Curr Value, Set Value

Set Value: Register (M000-M999), Decimal (0-65535)

Curr Value: Register (M000-M559)

Set Value	Decimal	Register (M000 - M999)
Curr Value		
Mxxx (M000 - M559)	0 - 65535 (0.0 - 6553.5 sec)	0 - 65535 (0.0 - 6553.5 sec)

2. Function

This instruction is an On Delay Timer to handle the subtraction formula and counter circuit by binary value. The internal clock is 0.1 second. While the start input is OFF, counting is not performed and Curr Value = Set value is maintained. Additionally, the TMR contact is turned off. Curr Value is decremented by 1 every 0.1 seconds as soon as the start input is turned on. The TMR contact is turned on when the Curr Value equals to 0. This state is maintained while the start input is at ON state.

Start Input	Curr Value	TMR Contact
OFF	Set Value	OFF
ON (Curr Value > 0)	Decrement by 1 every 0.1 seconds	OFF
ON (Curr Value = 0)	0	ON
ON→OFF (Curr Value > 0)	Return to Set Value	OFF
ON→OFF (Curr Value = 0)	Return to Set Value	ON→OFF

3. Ladder Program Example

The timer is reset when the FS100 power is turned on. Therefore, Curr Value becomes Set Value by the reset function even if the FS100 power is turned on in the ON state of the timer start input.

NOTE This instruction cannot be output multiple times to one relay.
 The register used as the current value of TMR/CNT/MLTMR instruction cannot be output multiple times.

<Ladder Diagram>

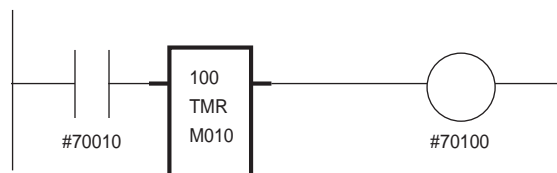

< Program >

```
STR #70010
TMR M010,100
OUT #70100
```

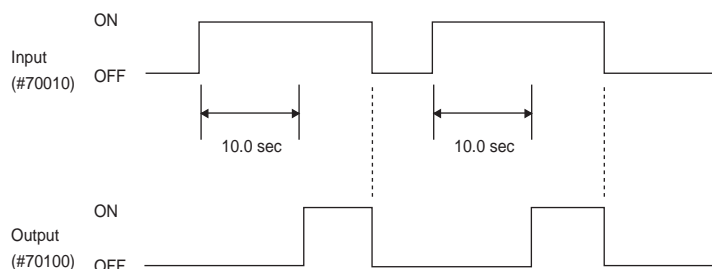

12.2.13 CNT Instruction

1. Format

CNT Curr Value, Set Value
 Set Value: Register (M000-M999), Decimal (0-65535)
 Curr Value: Register (M000-M559)

Set Value Curr Value	Decimal	Register (M000 - M999)
Mxxx (M000 - M559)	0 - 65535	0 - 65535

2. Function

Even if the counter input is turned to ON from OFF, counting is not performed and Curr Value = Set Value is maintained while the reset input is ON. Additionally, the CNT contact is turned OFF.
 The Curr Value is decremented by 1 each time the counter input is turned to ON from OFF in OFF state of the reset input. The CNT contact is turned on when the Curr Value becomes 0. This state is maintained in OFF state of the reset signals.
 Powering on the FS100 resets the counter. Consequently, the Curr Value remains as the Set Value by the reset function even if the counter input is in the ON state when the FS100 power is on.

Reset Input	Curr Value	CNT Contact
ON	Set Value	OFF
OFF (Curr Value > 0)	Decrement by 1 each time the counter input turns from OFF→ON	OFF
OFF (Curr Value = 0)	0	ON
OFF→ON (Curr Value > 0)	Return to Set Value	OFF
OFF→ON (Curr Value = 0)	Return to Set Value	ON→OFF

3. Ladder Program Example

The counter input is ignored once the counter is counted up. Start counting after turning the counter input to OFF from ON. The reset input is given priority when the counter input and reset input are turned on at the same time.

NOTE This instruction cannot be output multiple times to one relay.
 The register used as the current value of TMR/CNT/MLTMR instruction cannot be output multiple times.

<Ladder Diagram>

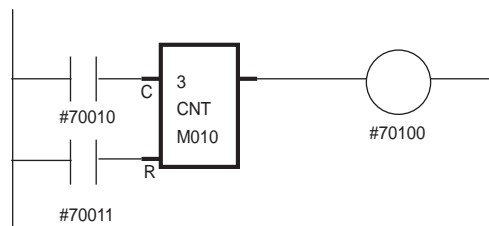

< Program >

```

STR #70010
Counter Input
STR #7011
Reset Input
CNT M010, 3
CNT instruction
OUT #70100
Output
    
```

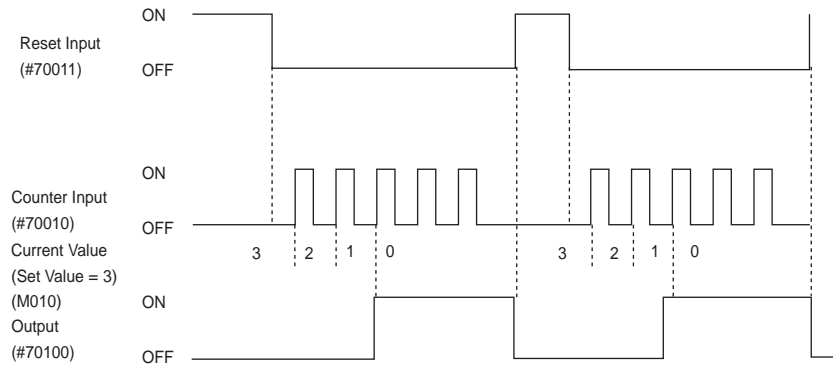
12.2.14 GSTR Instruction and GOUT Instruction

1. Format
 GSTR #XXXX0
 GOUT #XXXX0
 #XXXX0: Relay No. (byte)
2. Function
 The GSTR instruction stores the relay number (8 bits).
 The GOUT instruction outputs 8 bits data stored by the GSTR instruction to the relay number (8 bits).
3. Ladder Program Example

NOTE The GSTR instruction and the GOUT instruction should be pairs.
 This instruction cannot be output multiple times to one relay.

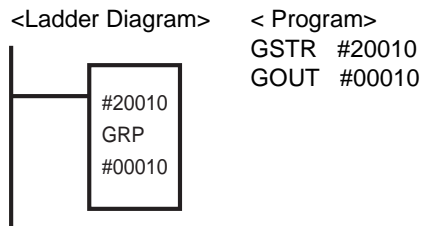

12.2.15 PLS Instruction

1. Format
PLS #XXXXX
#XXXXX: Relay No.
2. Function
The PLS instruction outputs one scanning pulse signal when specified signal is turned to ON from OFF.
3. Ladder Program Example



This instruction cannot be output multiple times to one relay.

<Ladder Diagram>

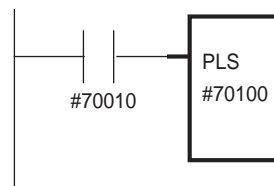

< Program >

```
STR #70010  
PLS #70100
```

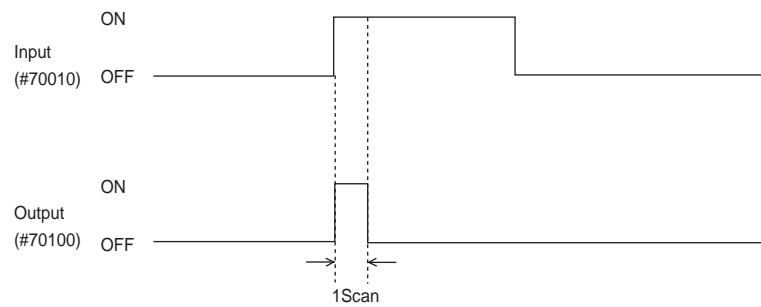

12.2.16 PLF Instruction

1. Format
 PLF #XXXXX
 #XXXXX: Relay No.
2. Function
 The PLF instruction outputs one scanning pulse signal when specified signal is turned to OFF from ON.
3. Ladder Program Example

NOTE This instruction cannot be output multiple times to one relay.

<Ladder Diagram>

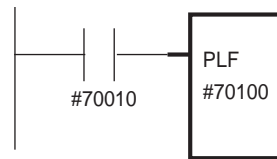

< Program >

```
STR #70010
PLF #70100
```

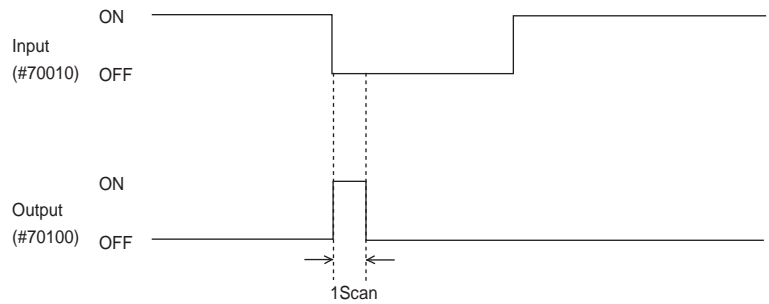

12.2.17 ADD Instruction

1. Format

ADD S1, S2, D

- S1: Source 1 Register (M000-M999)
 Decimal (0-65535)
- S1: Source 2 Register (M000-M999)
 Decimal (0-65535)
- D: Destination Register (M000-M599)

2. Function

S1 and S2 (16 bits unsigned binary data) are added and the addition result is output to D when the input signal is in ON state. As a result of calculation, the carry flag (#51400) and the zero flag (#51401) of a specific output are changed. The error flag (#51402) is not used.

Table 12-2: <Arithmetic Flag>

S1+S2	D	Carry Flag	Zero Flag	Error Flag
0	0	0	1	Not Used(0)
1-65535	1-65535	0	0	Not Used(0)
65536	0 (S1+S2-65536)	1	1	Not Used(0)
65536 or more	S1+S2-65536	1	0	Not Used(0)

Unused flag is cleared.

3. Ladder Program Example

NOTE The register used as the current value of TMR/CNT/MLTMR instruction cannot be output multiple times.

<Ladder Diagram>

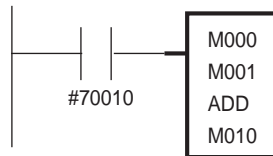

< Program>

```
STR #70010
ADD M000, M001, M010
```

12.2.18 SUB Instruction

1. Format

SUB S1, S2, D

- S1: Source 1 Register (M000-M999)
 Decimal (0-65535)
- S1: Source 2 Register (M000-M999)
 Decimal (0-65535)
- D: Destination Register (M000-M599)

2. Function

S1 and S2 (16 bits unsigned binary data) are subtracted and the subtraction result is output to D when input signal is in ON state. As a result of calculation, the carry flag (#51400) and the zero flag (#51401) of a specific output are changed. The error flag (#51402) is not used.

Table 12-3: <Arithmetic Flag>

S1-S2	D	Carry Flag	Zero Flag	Error Flag
0	0	0	1	Not Used(0)
1-65535	1-65535	0	0	Not Used(0)
Negative Number	S1-S2+65536	1	0	Not Used(0)

Unused flag is cleared.

3. Ladder Program Example

NOTE The register used as the current value of TMR/CNT/MLTMR instruction cannot be output multiple times.

<Ladder Diagram>

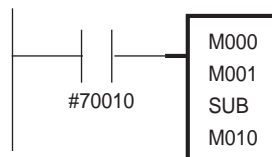

< Program>

```
STR #70010
SUB M000, M001, M010
```

12.2.19 MUL Instruction

1. Format

MUL S1, S2, Dn

S1: Source 1	Register (M000-M999) Decimal (0-65535)
S1: Source 2	Register (M000-M999) Decimal (0-65535)
Dn+1(High), Dn(Low): Destination	Register (M000-M599)

2. Function

S1 and S2 (16 bits unsigned binary data) are multiplied and the multiplication result is output to D when the input signal is in ON state. The carry flag (#51400), the zero flag (#51401), and the error flag (#51402) are not used.

Table 12-4: Arithmetic Flag

S1 x S2	Dn+1	Dn	Carry Flag	Zero Flag	Error Flag
0	0	0	Not Used(0)	Not Used(0)	Not Used(0)
1-65535	0	1-65535	Not Used(0)	Not Used(0)	Not Used(0)
65536 or more	High Word	Low Word	Not Used(0)	Not Used(0)	Not Used(0)

Unused flag is cleared.

3. Ladder Program Example

NOTE The register used as the current value of TMR/CNT/MLTMR instruction cannot be output multiple times.

<Ladder Diagram>

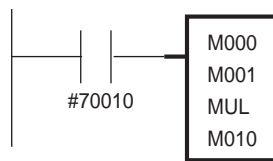

< Program >

```
STR #70010
MUL M000,M001,M010
When results=65536:
M011=1(0000000000000001 Binary Data)
M010=0(0000000000000000 Binary Data)
```

12.2.20 DIV Instruction

1. Format

DIV S1, S2, D

- S1: Source 1 Register (M000-M999)
 Decimal (0-65535)
- S1: Source 2 Register (M000-M999)
 Decimal (0-65535)
- D: Destination (Quotient) Register (M000-M599)

2. Function

S1 and S2 (16 bits unsigned binary data) are divided and the division result (Quotient) is output to D when the input signal is in ON state. As a result of calculation, the error flag (#51402) of a specific output is changed. The carry flag (#51400) and the zero flag (#51401) are not used.

Table 12-5: <Arithmetic Flag>

S1	S2	D	Carry Flag	Zero Flag	Error Flag
0-65535	Excepted for 0	Quotient	Not Used(0)	Not Used(0)	0
0-65535	0	No changes	Not Used(0)	Not Used(0)	1

Unused flag is cleared.

3. Ladder Program Example

NOTE The register used as the current value of TMR/CNT/MLTMR instruction cannot be output multiple times.

<Ladder Diagram>

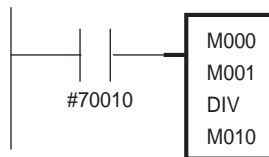

< Program >

```
STR #70010
DIV M000, M001, M010
```

12.2.21 MOD Instruction

1. Format

MOD S1, S2, D

- S1: Source 1 Register (M000-M999)
 Decimal (0-65535)
- S1: Source 2 Register (M000-M999)
 Decimal (0-65535)
- D: Destination (Residuum) Register (M000-M599)

2. Function

S1 and S2 (16 bits unsigned binary data) are divided and the division result (Residuum) is output to D when the input signal is in ON state. As a result of calculation, the error flag (#51402) of a specific output is changed. The carry flag (#51400) and the zero flag (#51401) are not used.

Table 12-6: <Arithmetic Flag>

S1	S2	D	Carry Flag	Zero Flag	Error Flag
0-65535	Excepted for 0	Surplus	Not Used(0)	Not Used(0)	0
0-65535	0	No changes	Not Used(0)	Not Used(0)	1

Unused flag is cleared.

3. Ladder Program Example

NOTE The register used as the current value of TMR/CNT/MLTMR instruction cannot be output multiple times.

<Ladder Diagram>

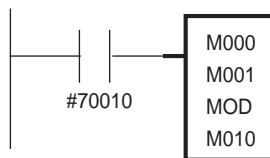

< Program >

```
STR #70010
MOD M000,M001,M010
```

12.2.22 BIN Instruction

1. Format
 BIN S, D

S: Source	Register (M000-M999) Relay (byte) #XXXX0 Relay (word) W#XXXX0
D: Destination	Register (M000-M599) Relay (byte) #XXXX0 Relay (word) W#XXXX0

2. Function

S (BCD data) is converted to binary data and is output to D when the input signal is in ON state. As a result of calculation, the carry flag (#51400) and the error flag (#51402) of a specific output are changed. The zero flag (#50401) is not used.

Table 12-7: <Arithmetic Flag>

S	D	Carry Flag	Zero Flag	Error Flag
BCD	BIN	0/1	Not Used(0)	0
Excepted for BCD	No Changes	0	Not Used(0)	1

The carry flag is set when the conversion result is the relay (byte) and the conversion data is more than 256 (BCD). Unused flag is cleared.

3. Ladder Program Example

NOTE This instruction cannot be output multiple times to one relay.
 The register used as the current value of TMR/CNT/MLTMR instruction cannot be output multiple times.

<Ladder Diagram>

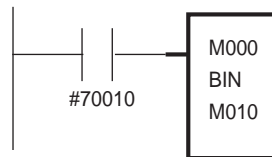

< Program >

```
STR #70010
BIN M000,M010
```

12.2.23 BCD Instruction

1. Format

BCD S, D

S: Source Register (M000-M999)
 Relay (byte) #XXXX0
 Relay (word) W#XXXX0

D: Destination Register (M000-M599)
 Relay (byte) #XXXX0
 Relay (word) W#XXXX0

2. Function

S (binary data) is converted to BCD data and is output to D when the input signal is in ON state. As a result of calculation, the carry flag (#51400) and the error flag (#51402) of a specific output are changed. The zero flag (#51401) is not used.

Table 12-8: <Arithmetic Flag>

S	D	Carry Flag	Zero Flag	Error Flag
9999 or less (binary data)	BCD	0/1	Not Used(0)	0
10000 or more (binary data)	No Changes	0	Not Used(0)	1

The carry flag is set when the conversion result is the relay (byte) and the conversion data is more than 256 (BCD). Unused flag is cleared.

3. Ladder Program Example

NOTE This instruction cannot be output multiple times to one relay.
 The register used as the current value of TMR/CNT/MLTMR instruction cannot be output multiple times.

<Ladder Diagram>

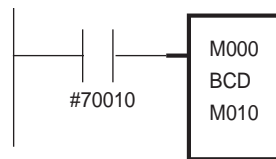

< Program >

```
STR #70010
BCD M000,M010
```

12.2.24 MOV Instruction

1. Format

MOV S, D

S: Source	Register (M000-M999) Decimal (0-65535) Relay (byte) #XXXX0 Relay (word) W#XXXX0
D: Destination	Register (M000-M599) Relay (byte) #XXXX0 Relay (word) W#XXXX0

2. Function

S is output to D in ON state of the input signal. As a result of calculation, the carry flag (#51400) of a specific output is changed. The zero flag (#51401) and the error flag (#51402) are not used. The carry flag is set when the transmission result is the relay (byte) and the transmission data is more than 256 (BCD).

3. Ladder Program Example

NOTE This instruction cannot be output multiple times to one relay.
 The register used as the current value of TMR/CNT/MLTMR instruction cannot be output multiple times.

<Ladder Diagram>

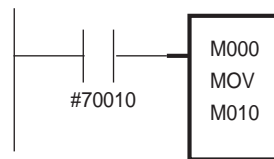

< Program >

```
STR #70010
MOV M000, M010
```

12.2.25 WAND Instruction

1. Format

WAND S1, S2, D

S1: Source	Register (M000-M999)
S2: Source	Decimal (0-65535)
	Relay (byte) #XXXXX0
	Relay (word) W#XXXXX0
D: Destination	Register (M000-M599)
	Relay (byte) #XXXXX0
	Relay (word) W#XXXXX0

2. Function

Logical AND operation between S1 and S2 is performed and the result is output to D when the input signal is in ON state. The logic operation is performed in each correspondence bit of S1 and S2.

	$D \leftarrow S1 \cap S2$	
S1	1100110011001100	Binary Data
S2	1010101010101010	Binary Data
	↓	
D	1000100010001000	Binary Data

3. Ladder Program Example

NOTE This instruction cannot be output multiple times to one relay.
 The register used as the current value of TMR/CNT/MLTMR instruction cannot be output multiple times.

<Ladder Diagram>

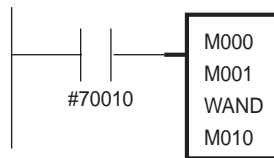

< Program >

```
STR #70010
WAND M000, M001, M010
```

12.2.26 WOR Instruction

1. Format

WOR S1, S2, D

S1: Source	Register (M000-M999)
S2: Source	Decimal (0-65535)
	Relay (byte) #XXXX0
	Relay (word) W#XXXX0
 D: Destination	 Register (M000-M599)
	Relay (byte) #XXXX0
	Relay (word) W#XXXX0

2. Function

Logical OR operation between S1 and S2 is performed and the result is output to D when the input signal is in ON state. The logic operation is performed in each correspondence bit of S1 and S2.

	$D \leftarrow S1 \cup S2$	
S1	1100110011001100	Binary Data
S2	1010101010101010	Binary Data
	↓	
D	1110111011101110	Binary Data

3. Ladder Program Example



This instruction cannot be output multiple times to one relay.
The register used as the current value of TMR/CNT/MLTMR instruction cannot be output multiple times.

<Ladder Diagram>

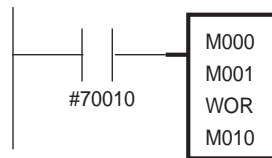

< Program >

```
STR #70010
WOR M000, M001, M010
```

12.2.27 WXOR Instruction

1. Format

WXOR S1, S2, D

S1: Source	Register (M000-M999)
S2: Source	Decimal (0-65535)
	Relay (byte) #XXXX0
	Relay (word) W#XXXX0
D: Destination	Register (M000-M599)
	Relay (byte) #XXXX0
	Relay (word) W#XXXX0

2. Function

Exclusive OR operation between S1 and S2 is performed and the result is output to D when the input signal is in ON state. The logic operation is performed in each correspondence bit of S1 and S2.

$$D \leftarrow (S1 \cup S2) \cap (\overline{S1} \cap \overline{S2})$$

S1	1100110011001100	Binary Data
S2	1010101010101010	Binary Data
	↓	
D	0110011001100110	Binary Data

3. Ladder Program Example

NOTE This instruction cannot be output multiple times to one relay.
 The register used as the current value of TMR/CNT/MLTMR instruction cannot be output multiple times.

<Ladder Diagram>

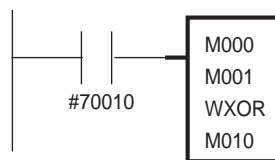

< Program >

```
STR #70010
WXOR M000, M001, M010
```

12.2.28 WNOT Instruction

1. Format
 WNOT S, D

S: Source	Register (M000-M999) Decimal (0-65535) Relay (byte) #XXXX0 Relay (word) W#XXXX0
D: Destination	Register (M000-M599) Relay (byte) #XXXX0 Relay (word) W#XXXX0

2. Function

Logical negation operation of S is performed and the result is output to D when the input signal is in ON state. The logic operation is performed in each correspondence bit of S1 and S2.

$D \leftarrow \bar{S}$

S1	1100110011001100	Binary Data
	↓	
D	0011001100110011	Binary Data

3. Ladder Program Example

NOTE This instruction cannot be output multiple times to one relay.
 The register used as the current value of TMR/CNT/MLTMR instruction cannot be output multiple times.

<Ladder Diagram>

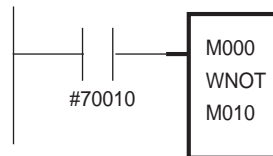

< Program >

```
STR #70010
WNOT M000, M010
```

12.2.29 SHL Instruction

1. Format

SHL S, n, D

S: Source	Register (M000-M999) Decimal (0-65535) Relay (byte) #XXXXX0 Relay (word) W#XXXXX0
n: Shift count	Decimal (0-16)
D: Destination	Register (M000-M599) Relay (byte) #XXXXX0 Relay (word) W#XXXXX0

2. Function

16 bits data contents of S is shifted to the high bit direction (left) n times and the result is output to D when the input signal is in ON state. 0 is shifted to the lowest bit (LSB) and the highest bit (MSB) is shifted to the carry flag.

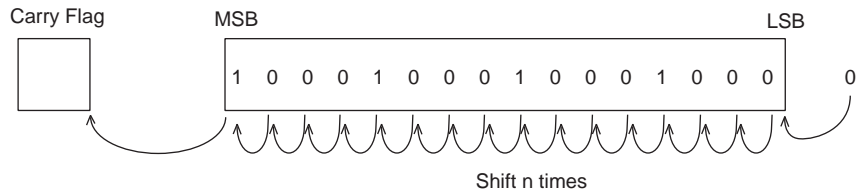

3. Ladder Program Example

This instruction cannot be output multiple times to one relay.

NOTE The register used as the current value of TMR/CNT/MLTMR instruction cannot be output multiple times. The operation is performed each scanning when the input signal is in ON state. For one time operation, use the pulse output instruction (PLS, PLF) in the input circuit.

<Ladder Diagram>

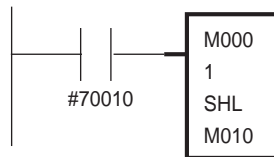

< Program >

```
STR #70010
SHL M000,1,M010
```

When M000 = 1000100010001000 (binary data), the result is as follows.
 M010: 0001000100010000
 Carry flag: 1

12.2.30 SHR Instruction

1. Format
 SHR S, n, D

S: Source	Register (M000-M999) Decimal (0-65535) Relay (byte) #XXXX0 Relay (word) W#XXXX0
n: Shift count	Decimal (0-16)
D: Destination	Register (M000-M599) Relay (byte) #XXXX0 Relay (word) W#XXXX0

2. Function

16 bits data contents of S is shifted to the low bit direction (right) n times and the result is output to D when the input signal is in ON state. 0 is shifted to the highest bit (MSB) and the lowest bit (LSB) is shifted to the carry flag.

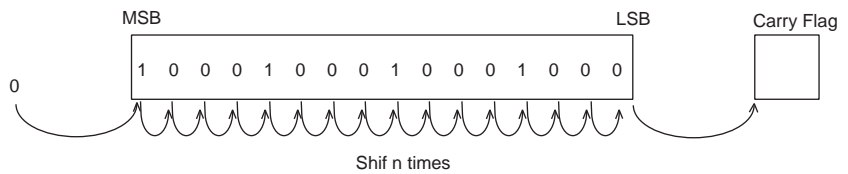

3. Ladder Program Example

NOTE This instruction cannot be output multiple times to one relay. The register used as the current value of TMR/CNT/MLTMR instruction cannot be output multiple times. The operation is performed each scanning when the input signal is in ON state. For one time operation, use the pulse output instruction (PLS, PLF) in the input circuit.

<Ladder Diagram>

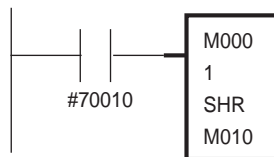

< Program>

```
STR #70010
SHR M000, 1, M010
```

When M000 = 1000100010001000 (binary data), the result is as follows.
 M010: 0100010001000100
 Carry flag: 0

12.2.31 ROL Instruction

1. Format

ROL S, n, D

S: Source	Register (M000-M999) Decimal (0-65535) Relay (byte) #XXXX0 Relay (word) W#XXXX0
n: Shift count	Decimal (0-16)
D: Destination	Register (M000-M599) Relay (byte) #XXXX0 Relay (word) W#XXXX0

2. Function

16 bits data contents of S is shifted to the high bit direction (left) n times and the result is output to D when the input signal is in ON state. The highest bit (MSB) is shifted to the carry flag and the lowest bit (LSB).

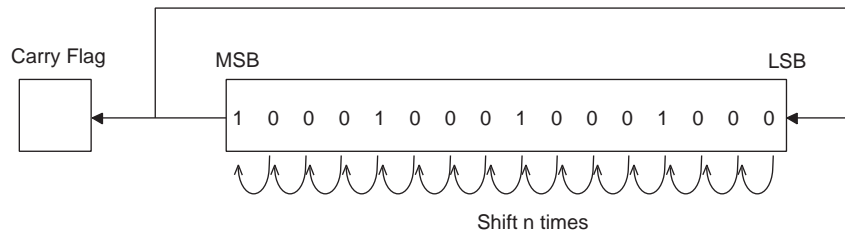

3. Ladder Program Example



This instruction cannot be output multiple times to one relay.
 The register used as the current value of TMR/CNT/MLTMR instruction cannot be output multiple times.
 The operation is performed each scanning when the input signal is in ON state. For one time operation, use the pulse output instruction (PLS, PLF) in the input circuit.

<Ladder Diagram>

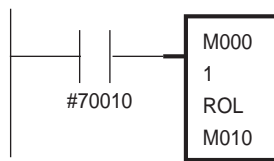

< Program >

```
STR #70010
ROL M000, 1, M010
```

When M000 = 1000100010001000 (binary data), the result is as follows.
 M010: 0001000100010001
 Carry flag: 1

12.2.32 ROR Instruction

1. Format
 ROR S, n, D

S: Source	Register (M000-M999) Decimal (0-65535) Relay (byte) #XXXX0 Relay (word) W#XXXX0
n: Shift count	Decimal (0-16)
D: Destination	Register (M000-M599) Relay (byte) #XXXX0 Relay (word) W#XXXX0

2. Function

16 bits data contents of S is shifted to the low bit direction (right) n times and the result is output to D when the input signal is in ON state. The lowest bit (LSB) is shifted to the carry flag and the highest bit (MSB).

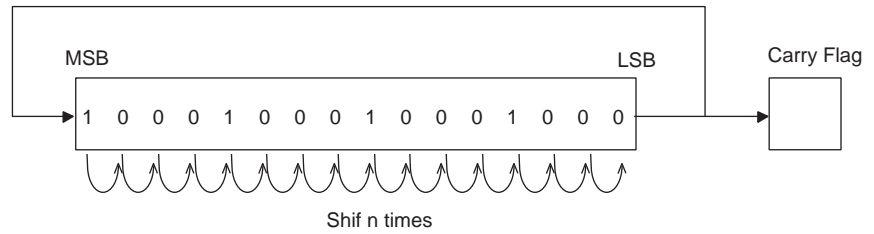

3. Ladder Program Example

NOTE This instruction cannot be output multiple times to one relay.
 The register used as the current value of TMR/CNT/MLTMR instruction cannot be output multiple times.
 The operation is performed each scanning when the input signal is in ON state. For one time operation, use the pulse output instruction (PLS, PLF) in the input circuit.

<Ladder Diagram>

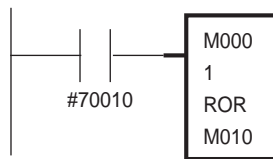

< Program >

```
STR #70010
ROL M000, 1, M010
```

When M000 = 1000100010001000 (binary data), the result is as follows.
 M010: 0100010001000100
 Carry flag: 0

12.2.33 MLTMR Instruction

1. Format

MLTMR Curr Value, Set Value
 Set Value: Register (M000-M999), Decimal (0-65535)
 Curr Value: Register (M000-M559)

	Set Value	Decimal	Register (M000 - M999)
Curr Value			
Mxxx (M000 - M559)		0 - 65535 (0.000 - 65.535 sec)	0 - 65535 (0.000 - 65.535 sec)

2. Function

This instruction is an On Delay Timer to handle the subtraction formula and counter circuit by binary value. The internal clock is 0.001 second.

While the start input is OFF, counting is not performed and Curr Value = Set value is maintained. Additionally, the MLTMR contact is turned off.

Curr Value is decremented by 1 every 0.001 seconds as soon as the start input is turned on. The MLTMR contact is turned on when the Curr Value equals to 0. This state is maintained while the start input is at ON state.

Start Input	Curr Value	TMR Contact
OFF	Set Value	OFF
ON (Curr Value > 0)	Decrement by 1 every 0.001 seconds	OFF
ON (Curr Value = 0)	0	ON
ON→OFF (Curr Value > 0)	Return to Set Value	OFF
ON→OFF (Curr Value = 0)	Return to Set Value	ON→OFF

3. Ladder Program Example

The timer is reset when the FS100 power is turned on. Therefore, Curr Value becomes Set Value by the reset function even if the FS100 power is turned on in the ON state of the timer start input.



This instruction cannot be output multiple times to one relay.
 The register used as the current value of TMR/CNT/MLTMR instruction cannot be output multiple times.

<Ladder Diagram>

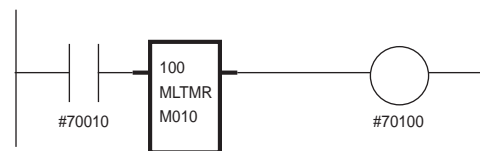

< Program >

```
STR #70010
MLTMR M010,100
OUT #70100
```

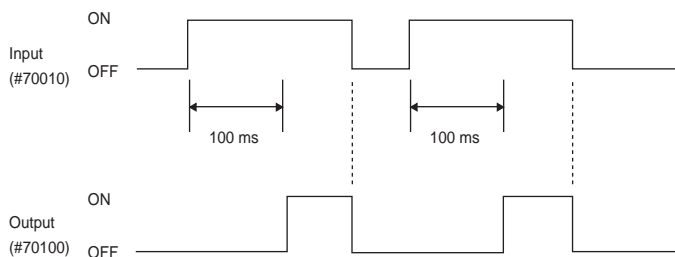

12.3 Arithmetic Flag

12.3.1 Flag Type

The arithmetic flag is a signal to reflect calculation result in the operation of the following steps. There are three types of flags. These flags are allocated to the following specific outputs.

- #51400: Carry Flag
- #51401: Zero Flag
- #51402: Error Flag



Refer to *Section 12.1 "List of Usable Instructions"* for the instructions which influence the flag.

(1) Carry Flag

- Case of ADD Instruction:
This flag is set when the place of digit is moved to the left as a result of the operation.
- Case of SUB Instruction:
This flag is set when the result is negative.

(2) Zero Flag

- Case of ADD or SUB Instruction:
This flag is set when the result is 0.

(3) Error Flag

- This flag is set when the error occurs. The instruction is not executed.

12.3.2 Flag Transition Under Scanning

- The flag is cleared before ladder program processing of every scanning.
- When the processing of the instruction which influences the flag starts, the flag is set by the operation result when the execution condition of the instruction consists. The flag is cleared when the execution condition of the instruction is a failure.
- The state of the flag does not change regardless of execution or non-execution in the processing of the instruction which does not influence the flag.

12.4 Default Setting

12.4.1 List of Ladder Programs

■ **System Ladder Section**

The standard ladder for the user's system is factory-set. (Two or more ladders may be used depending on the user's system.)
 The ladder program cannot be edited.

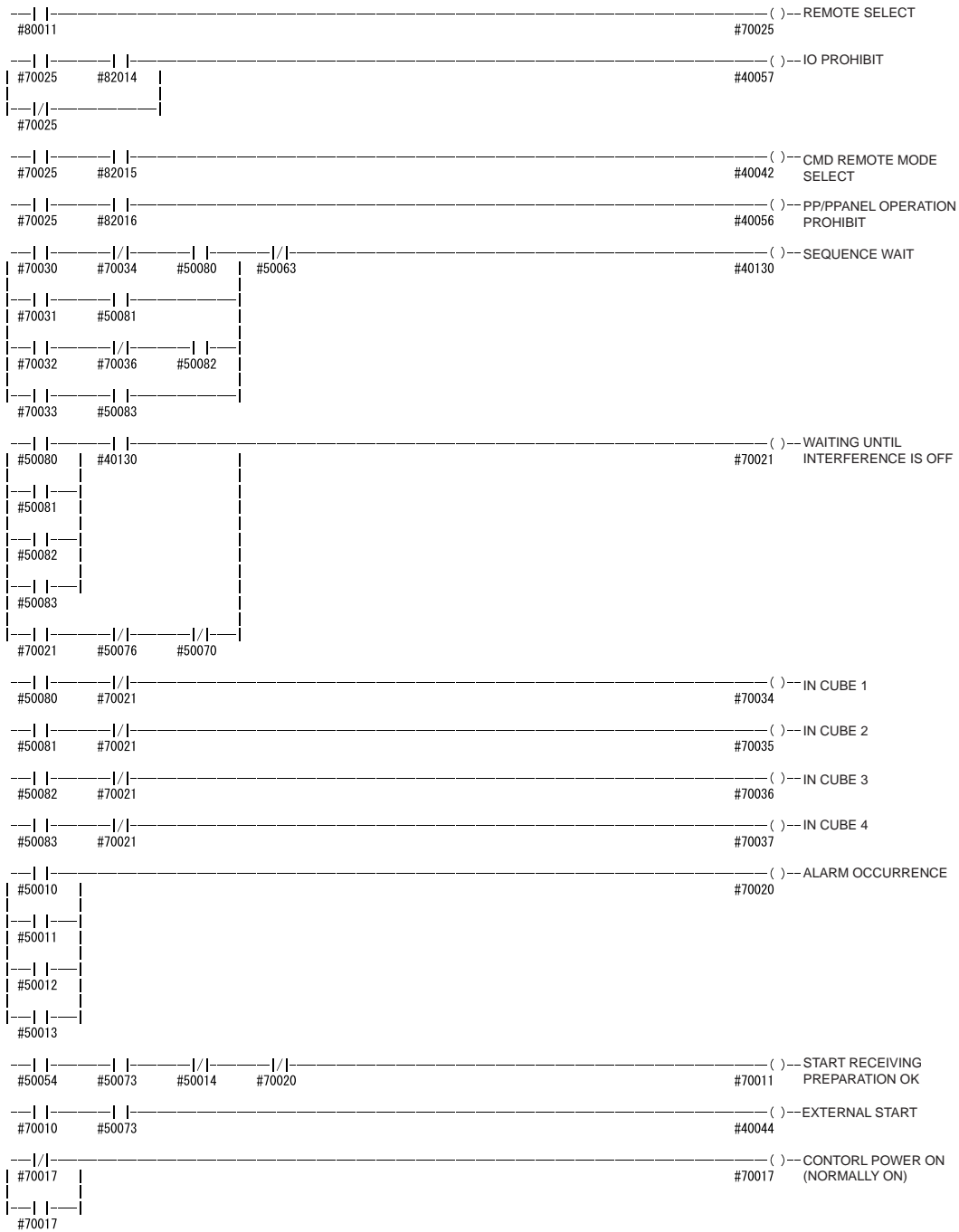

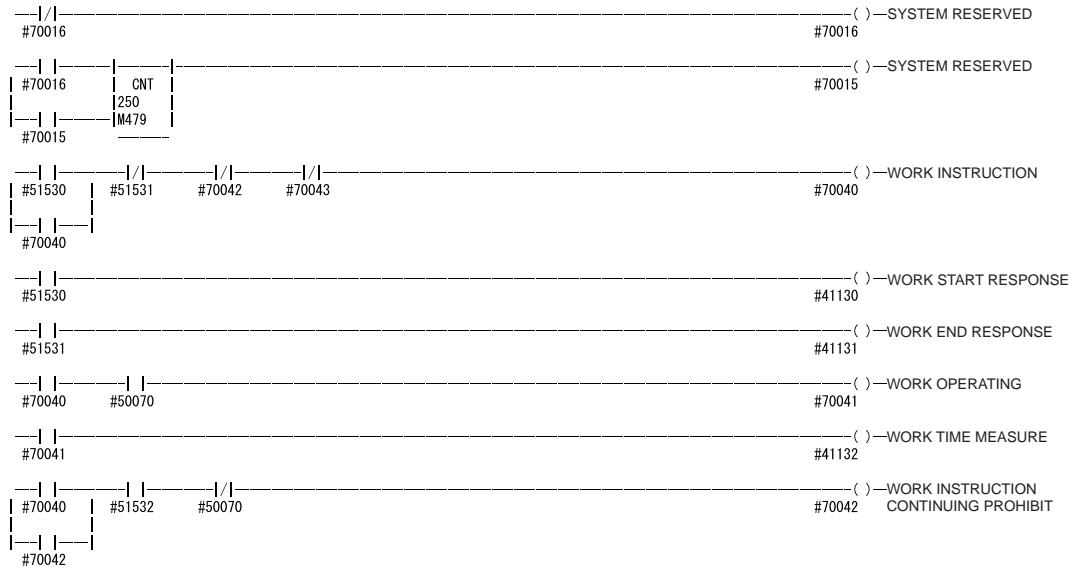

■ **User Ladder Section**

Signal connection specification and interface signals with system ladder are prepared prior to shipment. Including these signals, ladder programs can be edited.

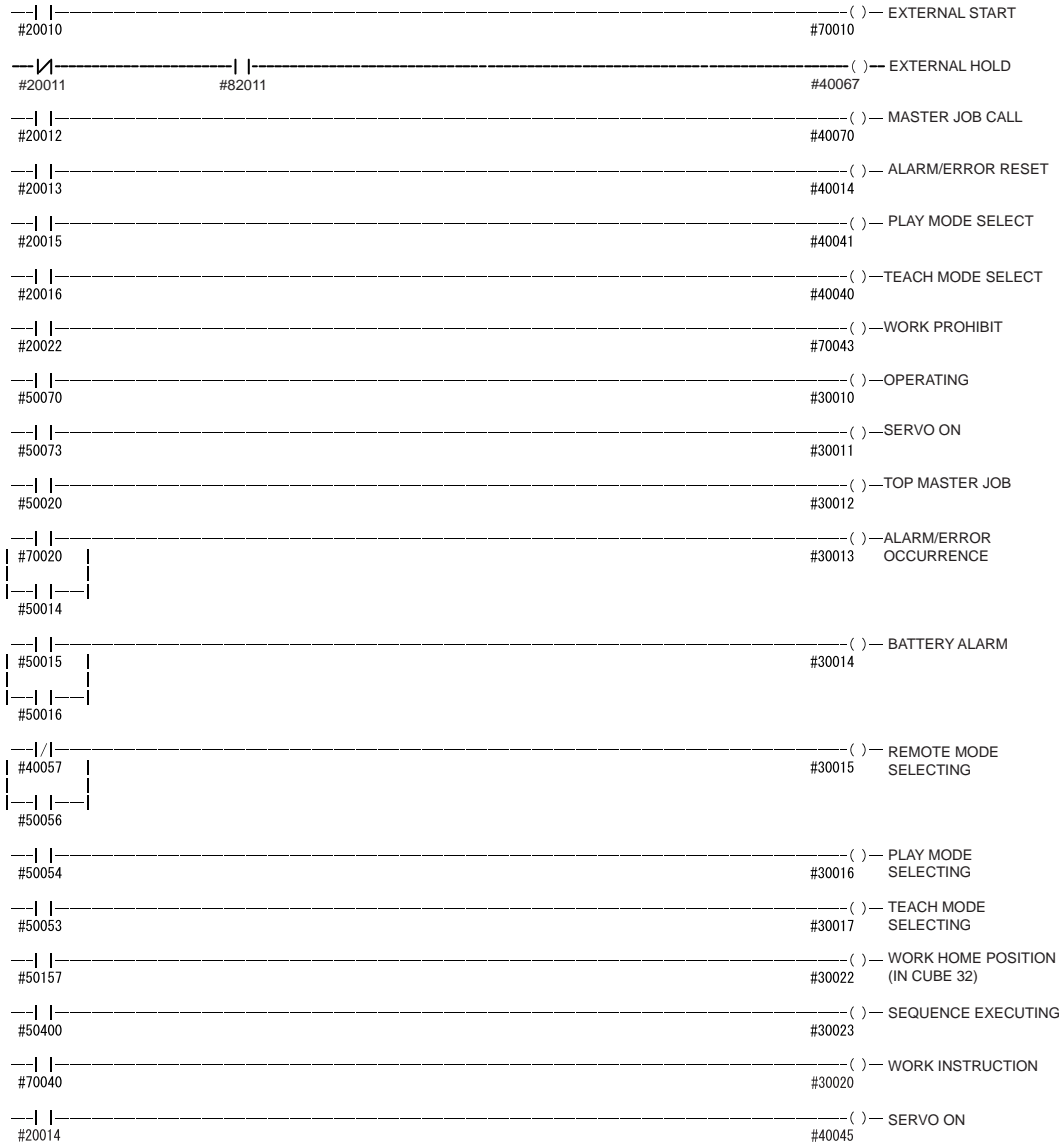

—|-----|
| GRP |
|#20030 |
#00010

—|-----|
| GRP |
|#20040 |
#00020

—|-----|
| GRP |
|#20050 |
#00030

—|-----|
| GRP |
|#20060 |
#00040

—|-----|
| GRP |
|#20070 |
#00050

—|-----|
| GRP |
|#20080 |
#00060

—|-----|
| GRP |
|#20090 |
#00070

—|-----|
| GRP |
|#20100 |
#00080

—|-----|
| GRP |
|#20110 |
#00090

—|-----|
| GRP |
|#20120 |
#00100

—|-----|
| GRP |
|#20130 |
#00110

—|-----|
| GRP |
|#20140 |
#00120

—|-----|
| GRP |
|#20150 |
#00130

—|-----|
| GRP |
|#20160 |
#00140

—|-----|
| GRP |
|#20170 |
#00150

GRP
#20180
#00160

GRP
#20190
#00170

GRP
#20200
#00180

GRP
#20210
#00190

GRP
#20220
#00200

GRP
#20230
#00210

GRP
#20240
#00220

GRP
#20250
#00230

GRP
#20260
#00240

GRP
#20270
#00250

GRP
#20280
#00260

GRP
#20290
#00270

GRP
#20300
#00280

GRP
#20310
#00290

GRP
#20320
#00300

—|——|
GRP
#20330
#00310
—|——|

—|——|
GRP
#20340
#00320
—|——|

—|——|
GRP
#20350
#00330
—|——|

—|——|
GRP
#20360
#00340
—|——|

—|——|
GRP
#20370
#00350
—|——|

—|——|
GRP
#20380
#00360
—|——|

—|——|
GRP
#20390
#00370
—|——|

—|——|
GRP
#20400
#00380
—|——|

—|——|
GRP
#20410
#00390
—|——|

—|——|
GRP
#20420
#00400
—|——|

—|——|
GRP
#20430
#00410
—|——|

—|——|
GRP
#20440
#00420
—|——|

—|——|
GRP
#20450
#00430
—|——|

—|——|
GRP
#20460
#00440
—|——|

—|——|
GRP
#20470
#00450
—|——|

GRP
#20480
#00460

GRP
#20490
#00470

GRP
#20500
#00480

GRP
#20510
#00490

GRP
#20520
#00500

GRP
#20530
#00510

GRP
#20540
#00520

GRP
#20550
#00530

GRP
#20560
#00540

GRP
#20570
#00550

GRP
#20580
#00560

GRP
#20590
#00570

GRP
#20600
#00580

GRP
#20610
#00590

GRP
#20620
#00600

—|——|
GRP
|#20630
|#00610
—|——|

—|——|
GRP
|#20640
|#00620
—|——|

—|——|
GRP
|#20650
|#00630
—|——|

—|——|
GRP
|#20660
|#00640
—|——|

—|——|
GRP
|#20670
|#00650
—|——|

—|——|
GRP
|#20680
|#00660
—|——|

—|——|
GRP
|#20690
|#00670
—|——|

—|——|
GRP
|#20700
|#00680
—|——|

—|——|
GRP
|#20710
|#00690
—|——|

—|——|
GRP
|#20720
|#00700
—|——|

—|——|
GRP
|#20730
|#00710
—|——|

—|——|
GRP
|#20740
|#00720
—|——|

—|——|
GRP
|#20750
|#00730
—|——|

—|——|
GRP
|#20760
|#00740
—|——|

—|——|
GRP
|#20770
|#00750
—|——|

GRP
#20780
#00760

GRP
#20790
#00770

GRP
#20800
#00780

GRP
#20810
#00790

GRP
#20820
#00800

GRP
#20830
#00810

GRP
#20840
#00820

GRP
#20850
#00830

GRP
#20860
#00840

GRP
#20870
#00850

GRP
#20880
#00860

GRP
#20890
#00870

GRP
#20900
#00880

GRP
#20910
#00890

GRP
#20920
#00900

—|——|
GRP
|#20930
|#00910
—|——|

—|——|
GRP
|#20940
|#00920
—|——|

—|——|
GRP
|#20950
|#00930
—|——|

—|——|
GRP
|#20960
|#00940
—|——|

—|——|
GRP
|#20970
|#00950
—|——|

—|——|
GRP
|#20980
|#00960
—|——|

—|——|
GRP
|#20990
|#00970
—|——|

—|——|
GRP
|#21000
|#00980
—|——|

—|——|
GRP
|#21010
|#00990
—|——|

—|——|
GRP
|#21020
|#01000
—|——|

—|——|
GRP
|#21030
|#01010
—|——|

—|——|
GRP
|#21040
|#01020
—|——|

—|——|
GRP
|#21050
|#01030
—|——|

—|——|
GRP
|#21060
|#01040
—|——|

—|——|
GRP
|#21070
|#01050
—|——|

GRP
#21080
#01060

GRP
#21090
#01070

GRP
#21100
#01080

GRP
#21110
#01090

GRP
#21120
#01100

GRP
#21130
#01110

GRP
#21140
#01120

GRP
#21150
#01130

GRP
#21160
#01140

GRP
#21170
#01150

GRP
#21180
#01160

GRP
#21190
#01170

GRP
#21200
#01180

GRP
#21210
#01190

GRP
#21220
#01200

—|——|
GRP
#21230
#01210
—|——|

—|——|
GRP
#21240
#01220
—|——|

—|——|
GRP
#21250
#01230
—|——|

—|——|
GRP
#21260
#01240
—|——|

—|——|
GRP
#21270
#01250
—|——|

—|——|
GRP
#21280
#01260
—|——|

—|——|
GRP
#10010
#30030
—|——|

—|——|
GRP
#10020
#30040
—|——|

—|——|
GRP
#10030
#30050
—|——|

—|——|
GRP
#10040
#30060
—|——|

—|——|
GRP
#10050
#30070
—|——|

—|——|
GRP
#10060
#30080
—|——|

—|——|
GRP
#10070
#30090
—|——|

—|——|
GRP
#10080
#30100
—|——|

—|——|
GRP
#10090
#30110
—|——|

GRP
#10100
#30120

GRP
#10110
#30130

GRP
#10120
#30140

GRP
#10130
#30150

GRP
#10140
#30160

GRP
#10150
#30170

GRP
#10160
#30180

GRP
#10170
#30190

GRP
#10180
#30200

GRP
#10190
#30210

GRP
#10200
#30220

GRP
#10210
#30230

GRP
#10220
#30240

GRP
#10230
#30250

GRP
#10240
#30260

—|——|
GRP
#10250
#30270
—|——|

—|——|
GRP
#10260
#30280
—|——|

—|——|
GRP
#10270
#30290
—|——|

—|——|
GRP
#10280
#30300
—|——|

—|——|
GRP
#10290
#30310
—|——|

—|——|
GRP
#10300
#30320
—|——|

—|——|
GRP
#10310
#30330
—|——|

—|——|
GRP
#10320
#30340
—|——|

—|——|
GRP
#10330
#30350
—|——|

—|——|
GRP
#10340
#30360
—|——|

—|——|
GRP
#10350
#30370
—|——|

—|——|
GRP
#10360
#30380
—|——|

—|——|
GRP
#10370
#30390
—|——|

—|——|
GRP
#10380
#30400
—|——|

—|——|
GRP
#10390
#30410
—|——|

GRP
#10400
#30420

GRP
#10410
#30430

GRP
#10420
#30440

GRP
#10430
#30450

GRP
#10440
#30460

GRP
#10450
#30470

GRP
#10460
#30480

GRP
#10470
#30490

GRP
#10480
#30500

GRP
#10490
#30510

GRP
#10500
#30520

GRP
#10510
#30530

GRP
#10520
#30540

GRP
#10530
#30550

GRP
#10540
#30560

—|——|
GRP
|#10550|
|#30570|
—|——|

—|——|
GRP
|#10560|
|#30580|
—|——|

—|——|
GRP
|#10570|
|#30590|
—|——|

—|——|
GRP
|#10580|
|#30600|
—|——|

—|——|
GRP
|#10590|
|#30610|
—|——|

—|——|
GRP
|#10600|
|#30620|
—|——|

—|——|
GRP
|#10610|
|#30630|
—|——|

—|——|
GRP
|#10620|
|#30640|
—|——|

—|——|
GRP
|#10630|
|#30650|
—|——|

—|——|
GRP
|#10640|
|#30660|
—|——|

—|——|
GRP
|#10650|
|#30670|
—|——|

—|——|
GRP
|#10660|
|#30680|
—|——|

—|——|
GRP
|#10670|
|#30690|
—|——|

—|——|
GRP
|#10680|
|#30700|
—|——|

—|——|
GRP
|#10690|
|#30710|
—|——|

GRP
#10700
#30720

GRP
#10710
#30730

GRP
#10720
#30740

GRP
#10730
#30750

GRP
#10740
#30760

GRP
#10750
#30770

GRP
#10760
#30780

GRP
#10770
#30790

GRP
#10780
#30800

GRP
#10790
#30810

GRP
#10800
#30820

GRP
#10810
#30830

GRP
#10820
#30840

GRP
#10830
#30850

GRP
#10840
#30860

—|——|
GRP
#10850
#30870
—|——|

—|——|
GRP
#10860
#30880
—|——|

—|——|
GRP
#10870
#30890
—|——|

—|——|
GRP
#10880
#30900
—|——|

—|——|
GRP
#10890
#30910
—|——|

—|——|
GRP
#10900
#30920
—|——|

—|——|
GRP
#10910
#30930
—|——|

—|——|
GRP
#10920
#30940
—|——|

—|——|
GRP
#10930
#30950
—|——|

—|——|
GRP
#10940
#30960
—|——|

—|——|
GRP
#10950
#30970
—|——|

—|——|
GRP
#10960
#30980
—|——|

—|——|
GRP
#10970
#30990
—|——|

—|——|
GRP
#10980
#31000
—|——|

—|——|
GRP
#10990
#31010
—|——|

GRP
#11000
#31020

GRP
#11010
#31030

GRP
#11020
#31040

GRP
#11030
#31050

GRP
#11040
#31060

GRP
#11050
#31070

GRP
#11060
#31080

GRP
#11070
#31090

GRP
#11080
#31100

GRP
#11090
#31110

GRP
#11100
#31120

GRP
#11110
#31130

GRP
#11120
#31140

GRP
#11130
#31150

GRP
#11140
#31160

—|——|
GRP
#11150
#31170

—|——|
GRP
#11160
#31180

—|——|
GRP
#11170
#31190

—|——|
GRP
#11180
#31200

—|——|
GRP
#11190
#31210

—|——|
GRP
#11200
#31220

—|——|
GRP
#11210
#31230

—|——|
GRP
#11220
#31240

—|——|
GRP
#11230
#31250

—|——|
GRP
#11240
#31260

—|——|
GRP
#11250
#31270

—|——|
GRP
#11260
#31280

12.4.2 I/O Alarms

System Section

Alarm No.	Register No.	I/O Alarm Message
9000	00	
9001	01	
9002	02	
9003	03	
9004	04	
9005	05	
9006	06	
9007	07	
9008	08	
9009	09	
9010	10	
9011	11	
9012	12	
9013	13	
9014	14	
9015	15	
9016	16	
9017	17	
9018	18	
9019	19	
9020	20	
9021	21	
:	:	
9063	63	
9064	64	
9065	65	
9066	66	
9067	67	
9068	68	
9069	69	
:	:	
9127	127	

User Section

12.4.3 I/O Messages

	Register No.	I/O Message	
System Section			
	00		
	01		
	02		
	03		
	04		
	05		
	06		
	07		
	08		
	09		
	10		
	11		
	12		
	13		
	14		
	15		
	16		
	17		
	18		
	19		
20			
21			
	:		
	63		
User Section			
	64		
	65		
	66		
	67		
	68		
	69		
		:	
		127	

13 How to Monitor Signals

Signal status can be monitored in the windows described in the following sections.

13.1 Monitoring I/O Signals

The following example shows one of the I/O monitor windows.

13.1.1 I/O Window

1. Select {IN/OUT} under the main menu.
2. Select an I/O window to be monitored.
 - The following I/O windows can be selected.
 - {UNIVERSAL INPUT}: Signals referred with instructions in JOBs (#0xxxx)
 - {UNIVERSAL OUTPUT}: Signals output from JOBs (#1xxxx)
 - {EXTERNAL INPUT}: Signals input from external devices (#2xxxx)
 - {EXTERNAL OUTPUT}: Signals output to external devices (#3xxxx)
 - {SPECIFIED INPUT}: Signals change manipulator operation mode (#4xxxx)
 - {SPECIFIED OUTPUT}: Signals inform manipulator operation mode and status (#5xxxx)
 - {AUX. RELAY}: Signals used in concurrent I/O (#7xxxx)
 - {CONTROL INPUT}: Signals refer to hardware status controller (#8xxxx)
 - {NETWORK INPUT}: Signals input from network devices (#25xxx)
 - {NETWORK OUTPUT}: Signals output to network devices (#35xxx)

The same applies to the signals on other windows.

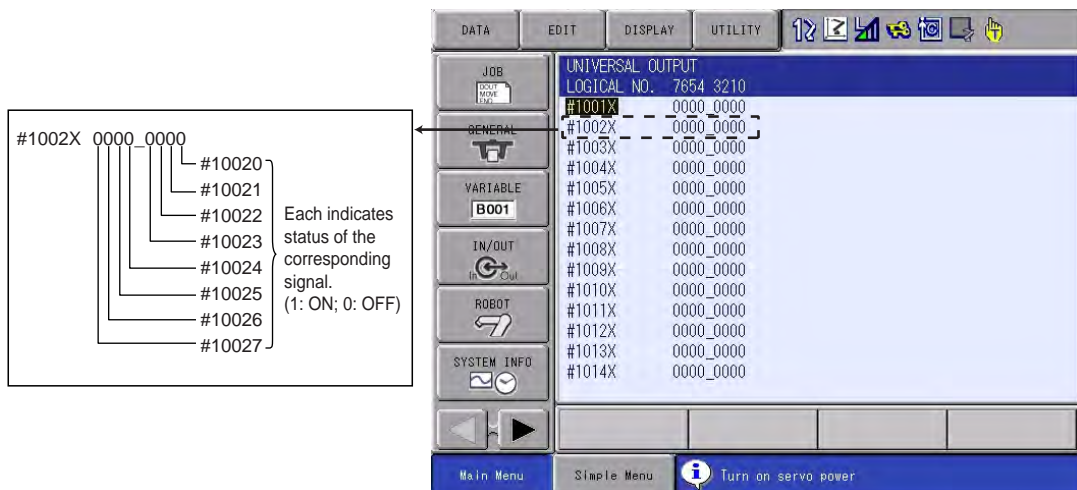

If the desired relay number is not displayed on the screen, perform the following operation to point the cursor to the desired relay number.

1. Point the cursor to the desired relay number.
 - (1) Move the cursor to a relay number, and press [SELECT].
 - (2) Input the desired relay number with the numeric keys, then press [ENTER] to point the cursor to the specified number.

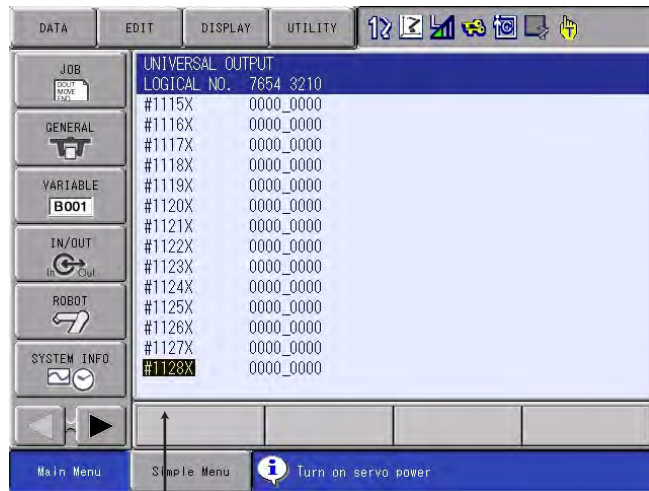





The cursor moved to the desired relay number.

13.2 I/O Status Window

The signal status can be monitored by switching the UNIVERSAL INPUT/OUTPUT, EXTERNAL INPUT/OUTPUT, SPECIFIED INPUT/OUTPUT windows to the I/O status window.

In the I/O status window, each signal name can be monitored as well. In the UNIVERSAL INPUT, UNIVERSAL OUTPUT, EXTERNAL INPUT, and EXTERNAL OUTPUT status windows, the signal status can be changed.

1. Select {DISPLAY} under the menu.
2. Select {DETAIL}.
 - The I/O window is switched to the I/O status window.
3. Select {SIMPLE}.
 - The I/O status window is switched to the I/O window.
4. Press the PAGE key .
 - Pressing the PAGE key  changes the relay number displayed on the screen.
 - The relay numbers are displayed in the following order each time the PAGE key  is pressed:
 #1001X → #1102X →...→ #1127X →#1128X (the last page) → #1001X →...
 - The relay numbers change in the following reverse order each time the SHIFT key  + the PAGE key  are pressed:
 #1001X → #1128X (the last page) → #1127X →...→ #1002X → #1001X →...
 - <Example> UNIVERSAL OUTPUT window

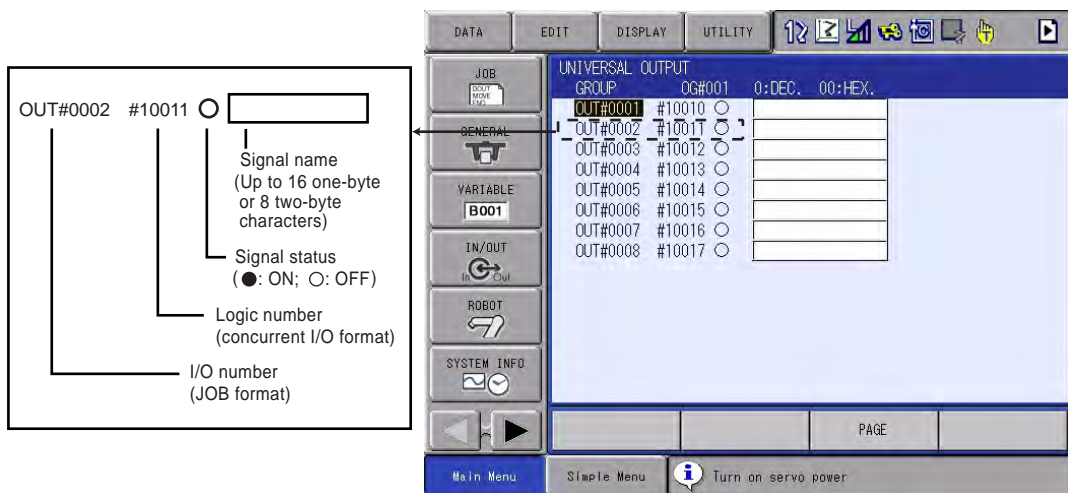

- In the Universal Output status window, the output signal on/off status can be changed. Once the status is changed, the status is maintained unless the next output instruction of JOB (DOUT) is executed.
- In the status windows “Universal Input”, “External Input” and “External Output”, the signal ON/OFF status can be forcibly changed. Once the status is changed, the status is maintained unless the forced change status is cancelled.

13.2.1 Registering Signal Name

1. Select the signal name to be registered.
 - (1) Move the cursor to the desired signal name to be registered, and press [SELECT].

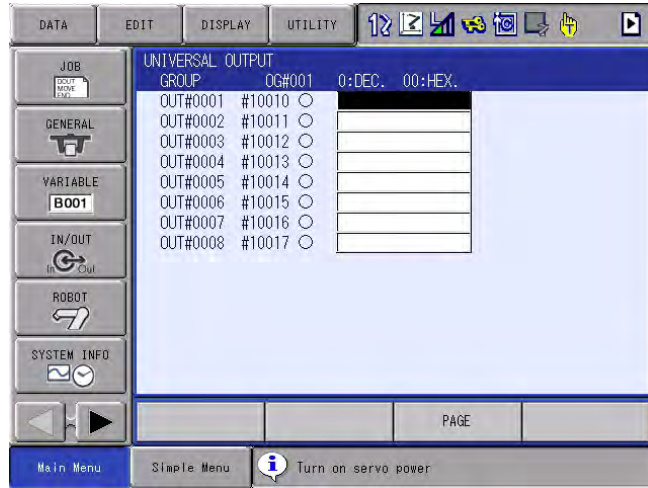

Or, move the cursor to the line of the signal whose name to be registered. Select {EDIT}, then {RENAME} from the menu.

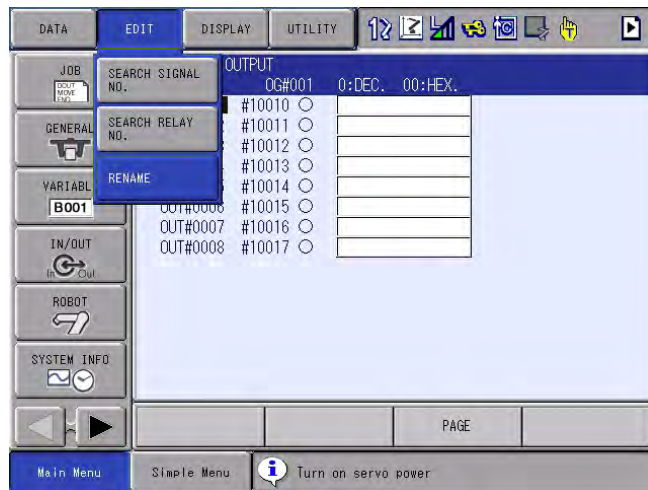

- (2) Characters can be entered.
 - Enter up to 16 one-byte (or 8 two-byte) characters.

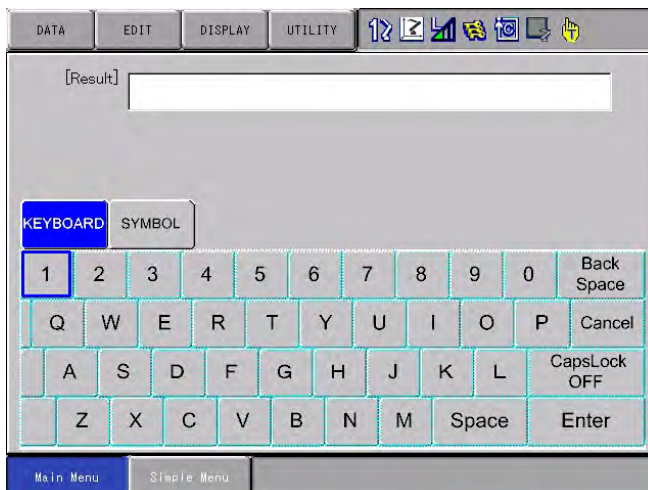

2. Enter the signal name.
3. Press [ENTER].
 - The name is registered.

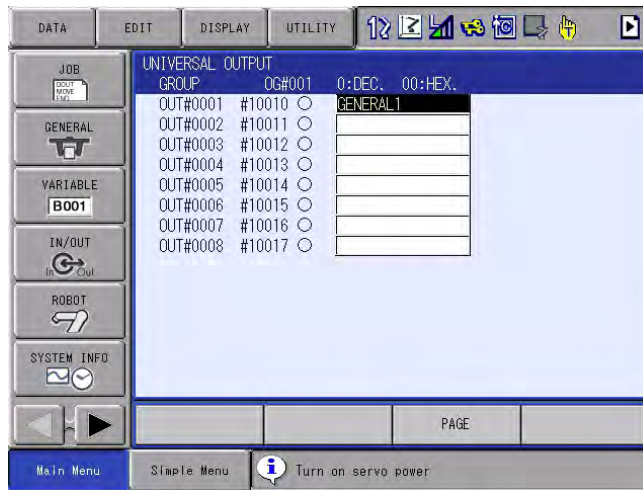

13.2.2 Changing Signal Status from UNIVERSAL OUTPUT Window

The ON-OFF status of the user output signals can be changed by performing the following procedure.

1. Select the signal status desired to be changed.
 - Move the cursor to the status (“●” or “○”) of desired signal in the UNIVERSAL OUTPUT window.

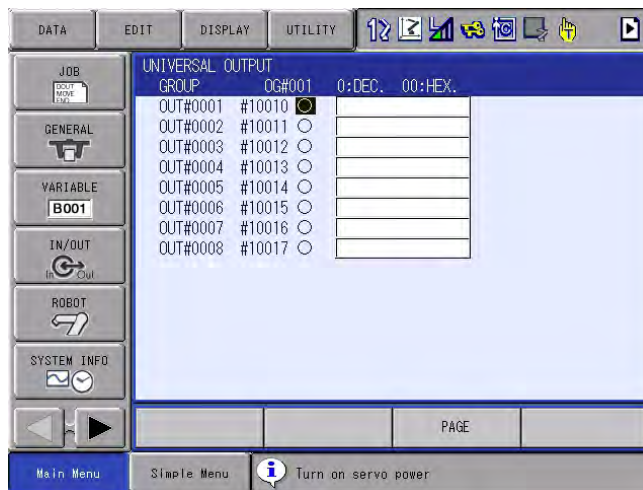

2. Select the signal status.

- The signal status changes each time the INTERLOCK key +[SELECT] are pressed.

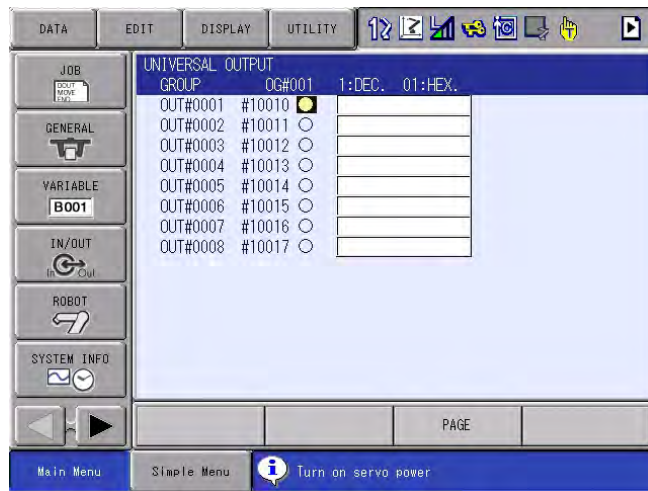

13.2.3 Changing Signal Status from UNIVERSAL INPUT Window

The status of the user input signals can be changed by performing the following procedure.

1. Select the signal desired to be changed.

- Move the cursor to the small box on the row of the signal to be changed in the UNIVERSAL INPUT window.

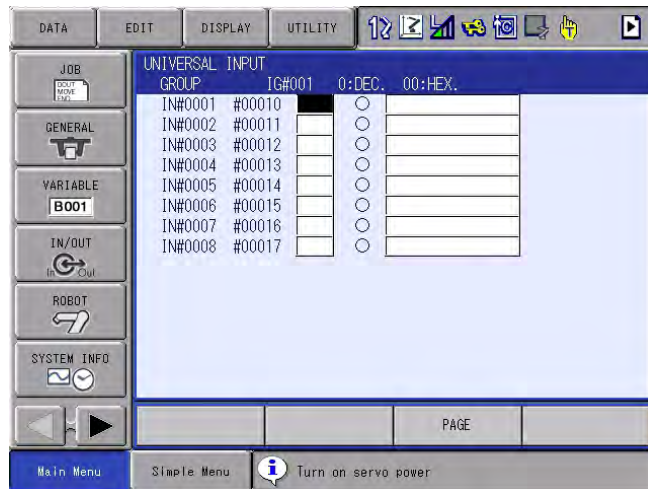

2. Select the "SIM" status.

- The signal status changes each time the [SELECT] key is pressed.
 - [SIM]: status of forced signal

- [Blank]: standard status

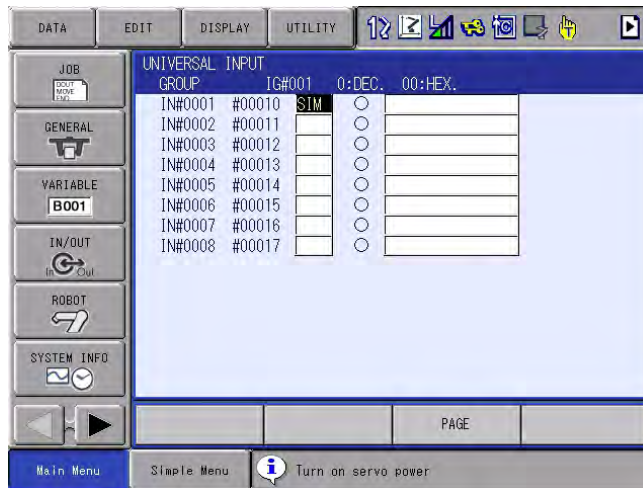

3. Select the signal status.

- Only for the signal specified as “SIM”, each time the cursor is moved to the signal status and the INTERLOCK key  + [SELECT] are pressed, the signal status changes (“●” or “○”).

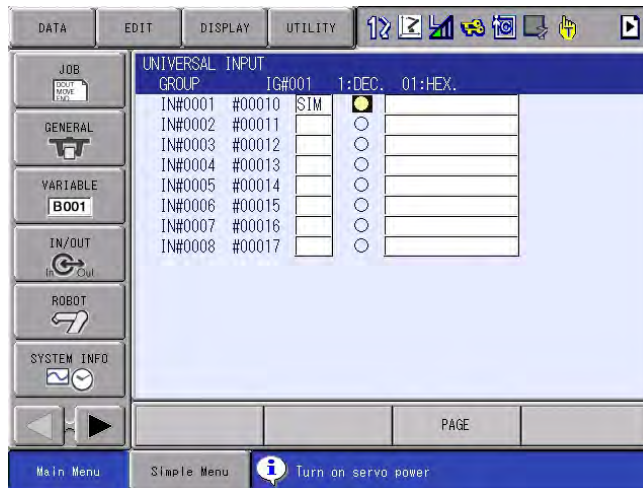



If "SIM" (forced signal) is selected, the user parameter S4C488 enables the continuous operation of the next instruction even if the signal status does not correspond to the condition when executing the WAIT instruction that specifies the infinite wait status for the user input signal.

(Example) When the following instruction is given in a JOB with "SIM" specified for the IN#0001.

WAIT IN#0001=ON

1. S4C488=0: infinite wait status until the signal status corresponds to the condition.
2. S4C488=non-0: executes the next instruction after a time specified in S2C488 (in units of 0.01 msec) has passed even if the signal status does not correspond to the condition.

For example, when the parameter is set to "S4C488=100", the above WAIT instruction executes the next instruction a second later if IN#0001 is set to "OFF" enabled by selecting "SIM".



- Perform the following check operation for safety when operating the manipulator with “SIM” (forced signal) is remained selected for the user input signal.

1. If any of the user input signal is set to “SIM”, the confirmation dialog box appears when starting a job.

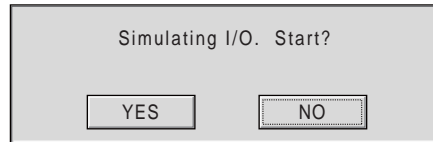

Select “YES” when executing the job with the “SIM” status.
The job starts running by performing the start operation again after the dialog box disappears.

Select “NO” when not executing the job with the “SIM” status.
Cancel the “SIM” status after the dialog box disappears.

2. If any of the user input signal is set to “SIM”, the confirmation dialog box appears when operating the manipulator (JOG, FWD/BWD operations) with the programming pendant.

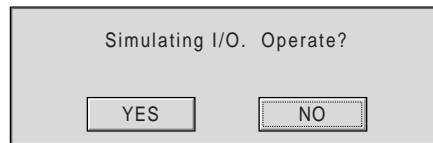

Select “YES” when operating the manipulator with the “SIM” status.
The manipulator can be operated after the dialog box disappears.

Select “NO” when not operating the manipulator with the “SIM” status.
Cancel the “SIM” status after the dialog box disappears.

- Concurrent I/O program reflects the actual signal status regardless of the “SIM” status of the user input signal.

For example, even if building a circuit in the ladder program as follows, #30010 is not ON when “SIM” is selected and the signal status set to “ON” (“●”) for #00010.
(The ON-OFF status of normal signal is referred in the ladder program.)

```
STR #00010
```

```
OUT #30010
```

13.2.3.1 Batch Selection of SIM

Follow the procedure below to set all the user input signals to "SIM".

1. Display the UNIVERSAL INPUT window.

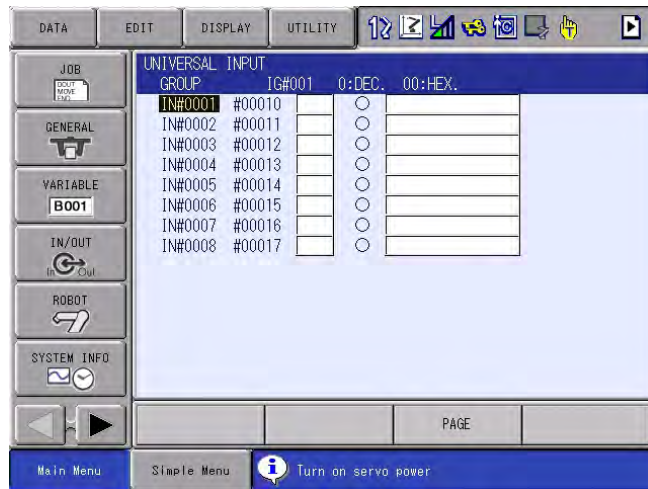

2. Select {EDIT} from the menu.

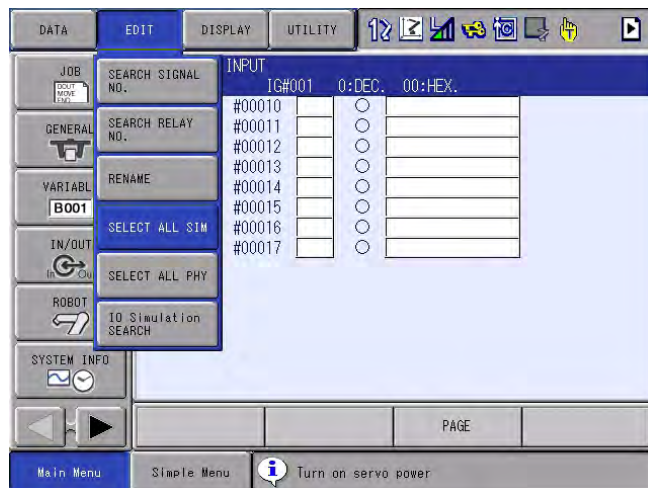

3. Select {SELECT ALL SIM}.

– Set all the user input signals to "SIM".

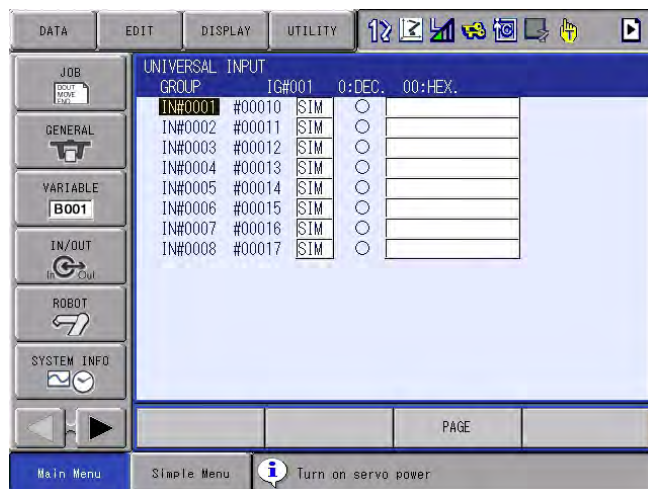

13.2.3.2 Batch Cancellation of SIM

Follow the procedure below to cancel the "SIM" status of all the user input signals.

1. Display the UNIVERSAL INPUT window.

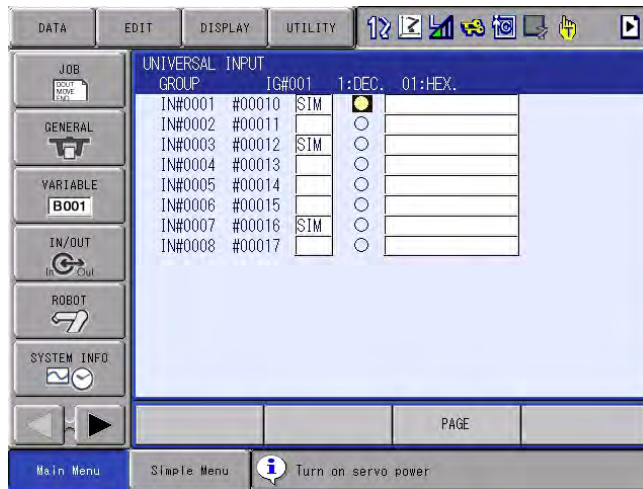

2. Select {EDIT} from the menu.

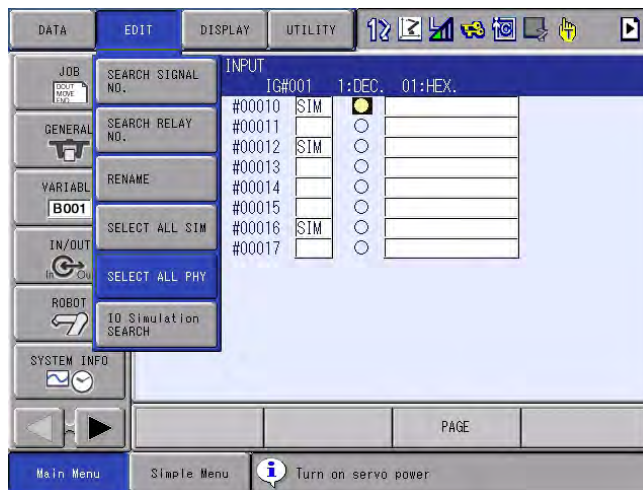

3. Select {SELECT ALL PHY}.
 - Cancels the "SIM" status of all the user input signals.

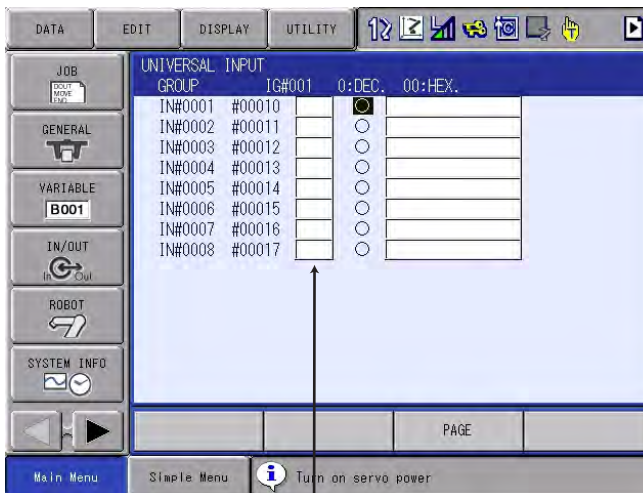

Cancels the "SIM" status of all the user input signals.
 (IN#0001 to IN#2048)

13.2.3.3 IO Simulation Search

Follow the procedure below to search the user input signals with “SIM” status.

1. Display the UNIVERSAL INPUT window.

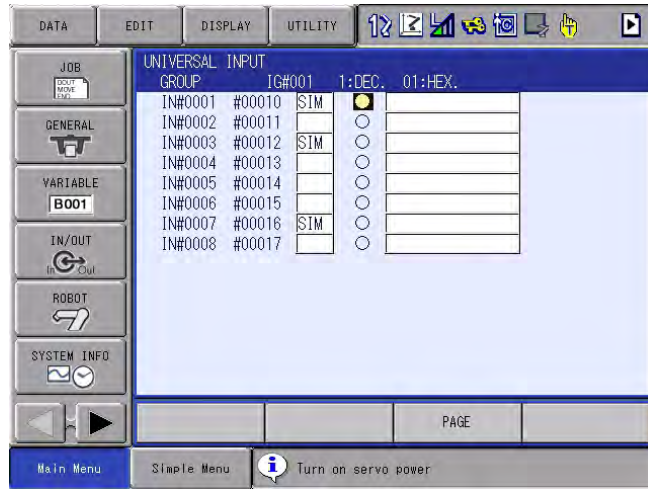

2. Select {EDIT} from the menu.

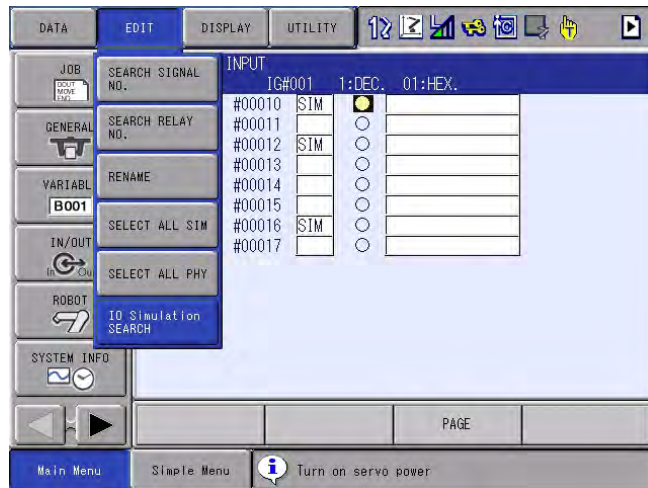

3. Select {IO Simulation SEARCH}.

– When there is a user input signal with “SIM” status, the following is shown:

- (1) “■” are added on the left of the signals with the “SIM” status.
- (2) “(IO Simulation Search)” is shown in the title.

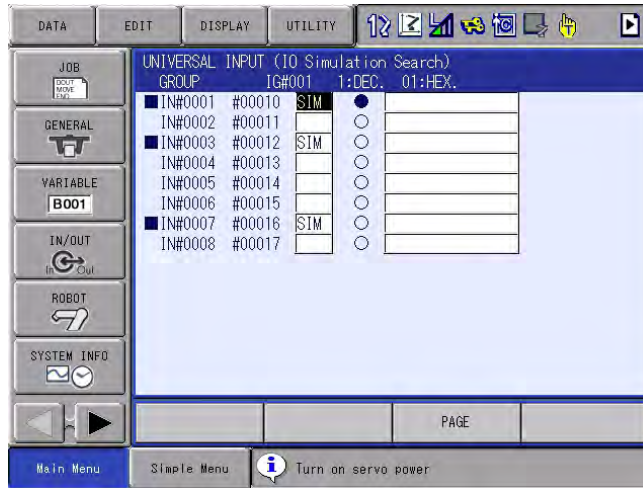

– When there is no user input signal with “SIM” status, the following is shown:

- (1) “ERROR 2050: Address not found” is shown.
- (2) Does not move on to the IO simulation search.

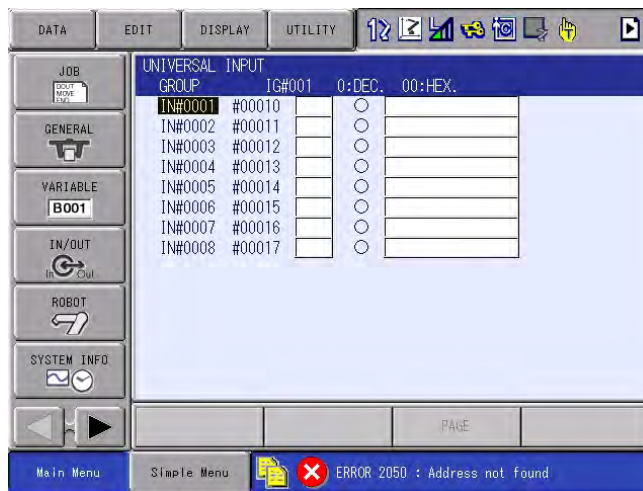

 During the IO simulation search, the search status does not change even if the signal’s “SIM” status changes. “■” is added to the signal which was “SIM” status when the search started.

Follow the procedure below to jump to the user input signal with “SIM” status during the IO simulation search.

1. Press the cursor key [↓].
 - The cursor moves to the next signal with “SIM” status.
2. Press the cursor key [↑].
 - The cursor moves to the previous signal with “SIM” status.

The IO simulation search is cancelled in the following cases:

- when [CANCEL] is pressed during the IO simulation search
- when the menu {EDIT}, then {SELECT ALL SIM} are selected during the IO simulation search
- when the menu {EDIT}, then {SELECT ALL PHY} are selected during the IO simulation search
- when the menu {EDIT}, then {SEARCH SIGNAL NO.} or {SEARCH RELAY NO.} are selected during the IO simulation search
- when the display is changed from the I/O status window (DETAIL) to the I/O window (SIMPLE)
- when the window is closed
- when the page is switched

13.2.4 Changing Signal Status from EXTERNAL OUTPUT Window

Follow the procedure below to change the status of the external output signals.

1. Select the signal to be changed.
 - Move the cursor to the small box on the row of the signal to be changed in the EXTERNAL OUTPUT window.

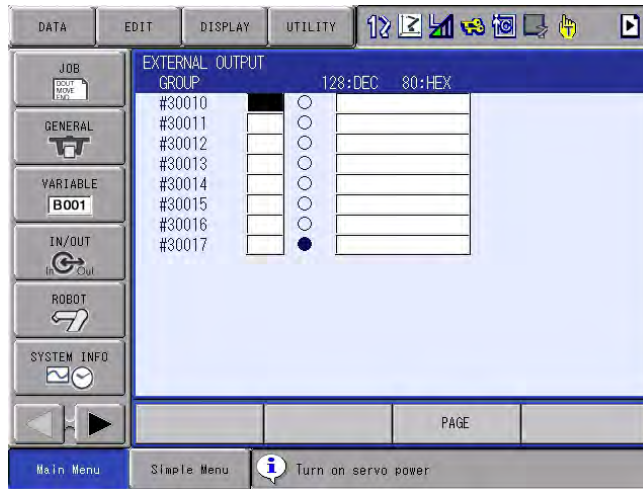

2. Select the "SIM" status.
 - The signal status changes each time the [SELECT] key is pressed.
 - [SIM]: status of forced signal
 - [Blank]: standard status

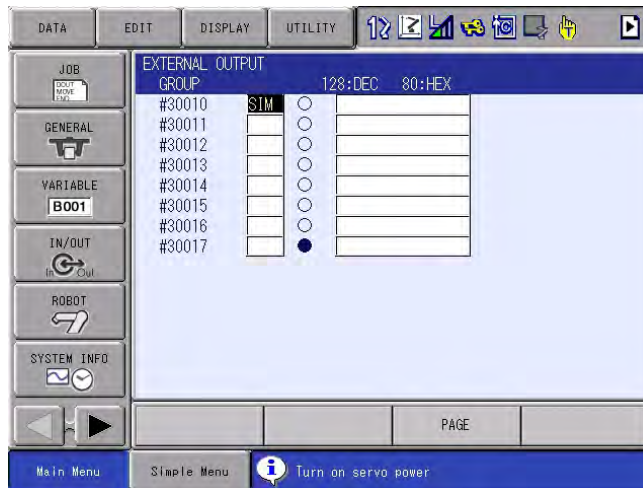

3. Select the signal status.

- Only for the signal specified as “SIM”, each time the cursor is moved to the signal status and the INTERLOCK key  + [SELECT] are pressed, the signal status changes (“●” or “○”).

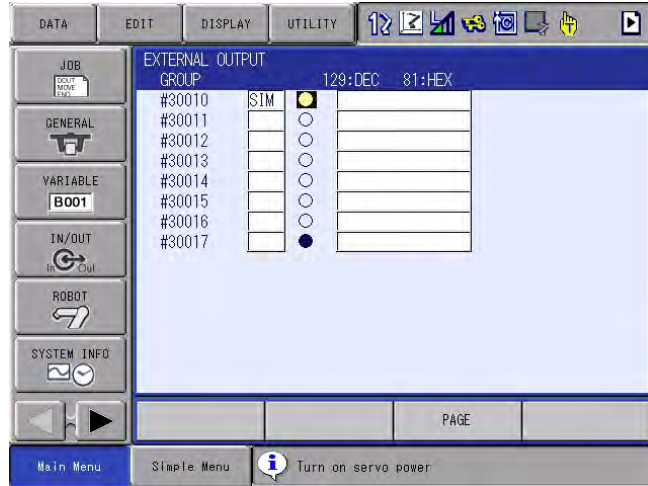
**CAUTION**

- Changing the status of external output signal by specifying “SIM” also changes the signals output to the actual external devices. Before forcibly changing the signal status, verify the destination device of each signal, and check on how the change effects on the device.

Failure to observe this caution may result in injury or damage to equipment.



- Perform the following check operation for safety when operating the manipulator with “SIM” (forced signal) is remained selected for the external output signal.

1. If any of the external output signal is set to “SIM”, the confirmation dialog box appears when starting a job.

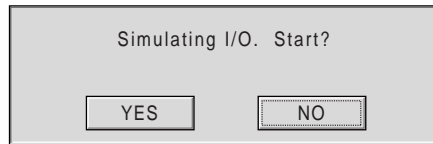

Select “YES” when executing the job with the “SIM” status.
The job starts running by performing the start operation again after the dialog box disappears.

Select “NO” when not executing the job with the “SIM” status.
Cancel the “SIM” status after the dialog box disappears.

2. If any of the external output signal is set to “SIM”, the confirmation dialog box appears when operating the manipulator (JOG, FWD/BWD operations) with the programming pendant.

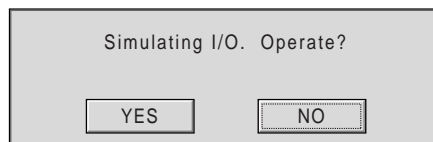

Select “YES” when operating the manipulator with the “SIM” status.
The manipulator can be operated after the dialog box disappears.

Select “NO” when not operating the manipulator with the “SIM” status.
Cancel the “SIM” status after the dialog box disappears.

- Concurrent I/O program reflects the actual signal status regardless of the “SIM” status of the external output signal.

For example, even if building a circuit in the ladder program as follows, #30011 is not ON when “SIM” is selected and the signal status set to “ON” (“●”) for #30010.
(The ON-OFF status of normal signal is referred in the ladder program.)

```
STR #30010  
OUT #30011
```

13.2.4.1 Batch Selection of SIM

Follow the procedure below to set all the external output signals to “SIM”.

1. Display the EXTERNAL OUTPUT window.

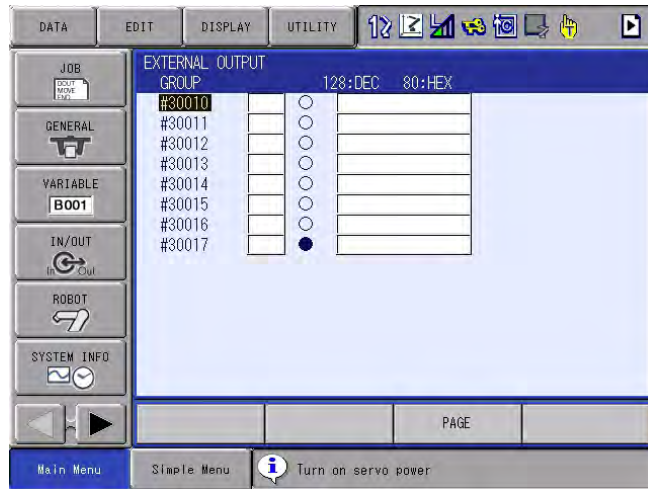

2. Select {EDIT} from the menu.

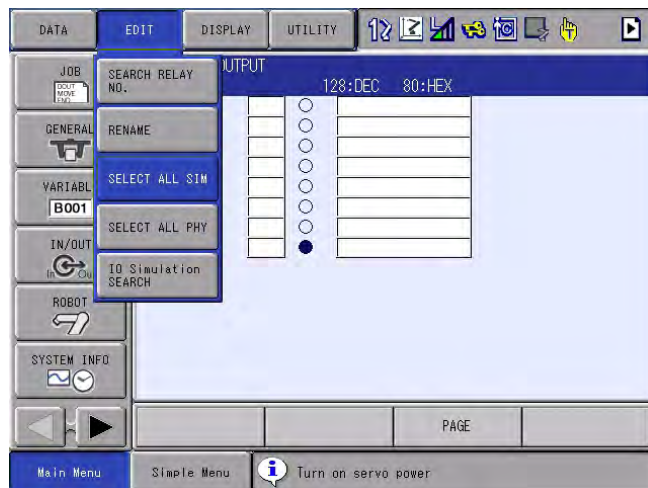

3. Select {SELECT ALL SIM}.

– Set all the external output signals to “SIM”.

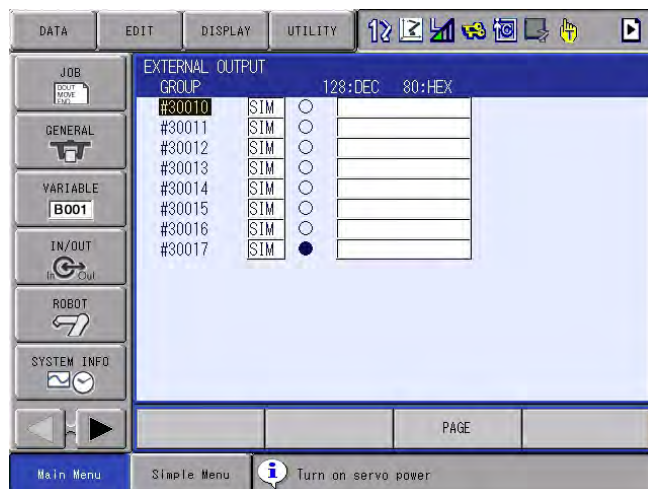

13.2.4.2 Batch Cancellation of SIM

Follow the procedure below to cancel the “SIM” status of all the external output signals.

1. Display the EXTERNAL OUTPUT window.

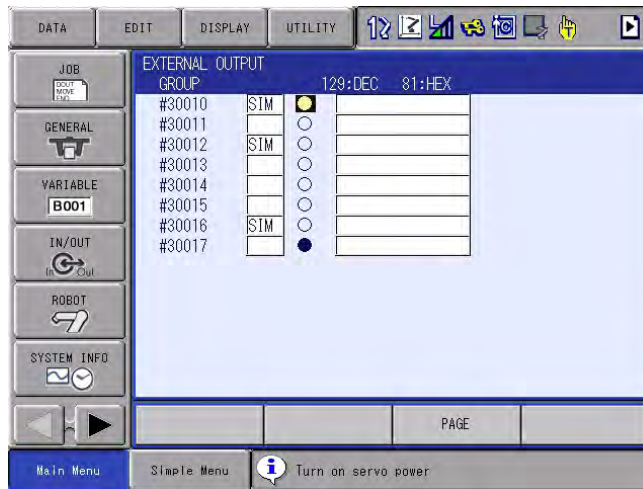

2. Select {EDIT} from the menu.

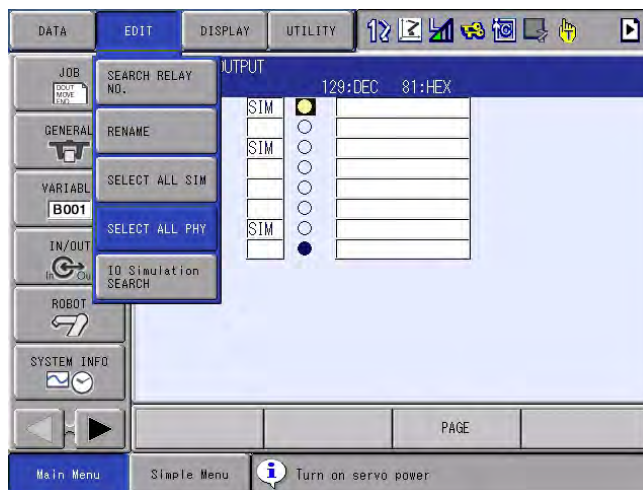

3. Select {SELECT ALL PHY}.

– Cancels the “SIM” status of all the external output signals.

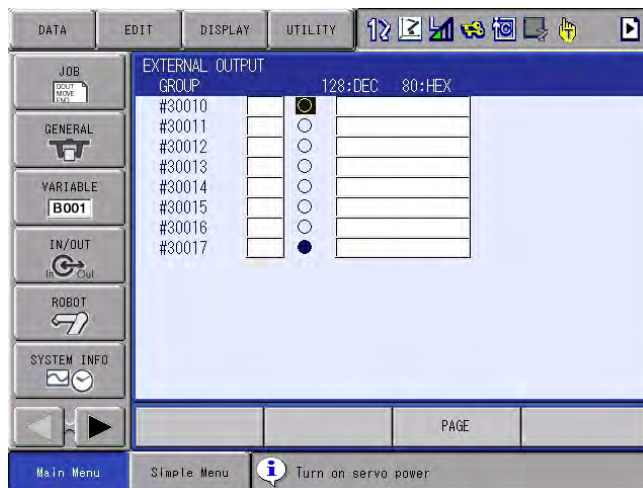

13.2.4.3 IO Simulation Search

Follow the procedure below to search the external output signals with "SIM" status.

1. Display the EXTERNAL OUTPUT window.

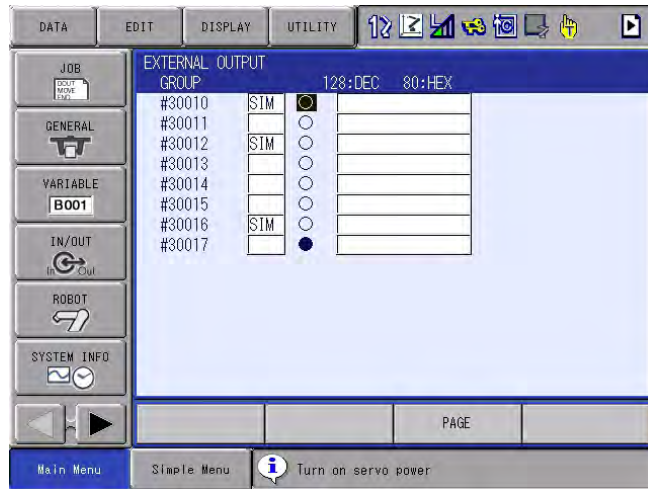

2. Select {EDIT} from the menu.

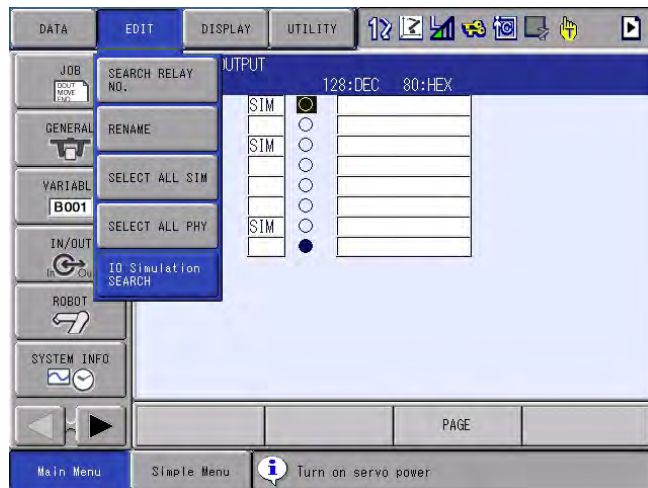

3. Select {IO Simulation SEARCH}.

– When there is an external output signal with “SIM” status, the following is shown:

- (1) “■” are added on the left of the signals with the “SIM” status.
- (2) “(IO Simulation Search)” is shown in the title.



– When there is no external output signal with “SIM” status, the following is shown:

- (1) “ERROR 2050: Address not found” is shown.
- (2) Does not move on to the IO simulation search.

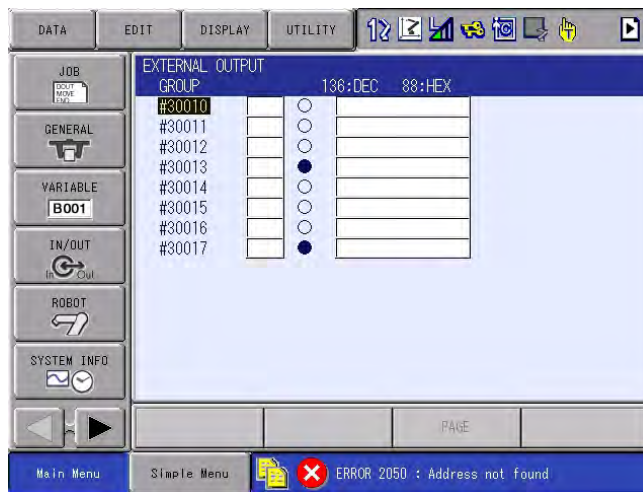

 During the IO simulation search, the search status does not change even if the signal’s “SIM” status changes. “■” is added to the signal which was “SIM” status when the search started.

Follow the procedure below to jump to the external output signal with "SIM" status during the IO simulation search.

1. Press the cursor key [↓].
 - The cursor moves to the next signal with "SIM" status.
2. Press the cursor key [↑].
 - The cursor moves to the previous signal with "SIM" status.

The IO simulation search is cancelled in the following cases:

- when [CANCEL] is pressed during the IO simulation search
- when the menu {EDIT}, then {SELECT ALL SIM} are selected during the IO simulation search
- when the menu {EDIT}, then {SELECT ALL PHY} are selected during the IO simulation search
- when the menu {EDIT}, then {SEARCH SIGNAL NO.} or {SEARCH RELAY NO.} are selected during the IO simulation search
- when the display is changed from the I/O status window (DETAIL) to the I/O window (SIMPLE)
- when the window is closed
- when the page is switched

13.2.5 Changing Signal Status from EXTERNAL INPUT Window

The status of the external input signals can be changed by performing the following procedure.

1. Select the signal desired to be changed.
 - Move the cursor to the small box on the row of the signal to be changed in the UNIVERSAL INPUT window.

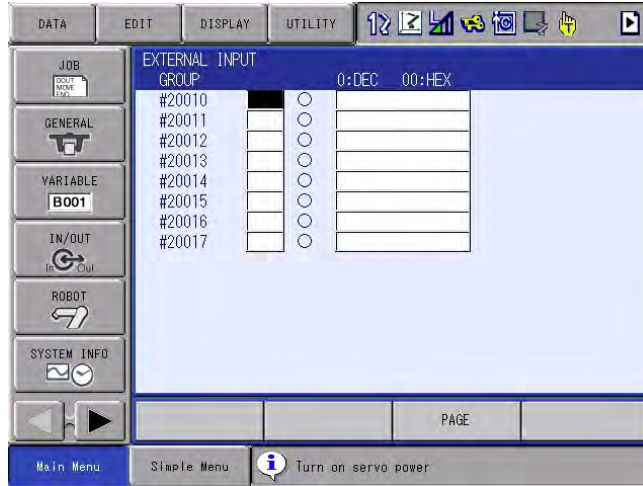

2. Select the forced status.
 - The signal status changes each time the [SELECT] key is pressed.
 - [SIM]: status of forced signal
 - [Blank]: standard status

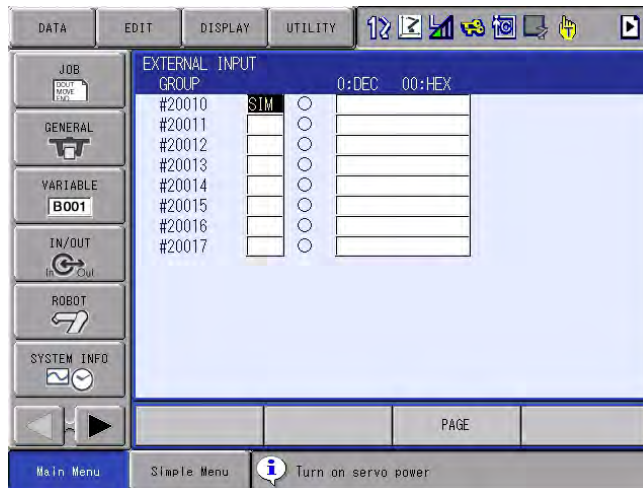

3. Select the signal status.

- Only for the signal specified as “SIM”, each time the cursor is moved to the signal status and the INTERLOCK key  + [SELECT] are pressed, the signal status changes (“●” or “○”).

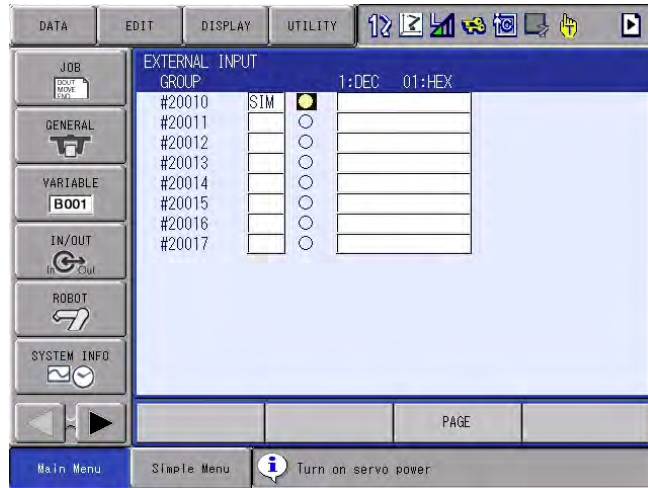
**CAUTION**

- When changing the status of external input signal by specifying “SIM”, parameters can be set as follows:

S2C394=0 (Default)

Changes only the internal status (signal indication) if the output status of signals to the external device has been changed with the concurrent I/O program due to the change of external input signals. The output status for external device remains the same condition when the “SIM” mode was selected.

Restores the original status by cancelling all the “SIM” mode.

S2C394=1

Changes the signals output to the actual external devices if the output status of signals to the external device has been changed with the concurrent I/O program due to the change of external input signals.

Before forcibly changing the signal status, verify the destination device of each signal, and check on how the change effects on the device.

Failure to observe this caution may result in injury or damage to equipment.



- Perform the following check operation for safety when operating the manipulator with "SIM" (forced signal) is remained selected for the external input signal.

1. If any of the external input signal is set to "SIM", the confirmation dialog box appears when starting a job.

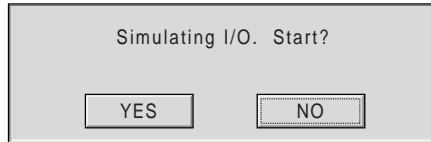

Select "YES" when executing the job with the "SIM" status.
The job starts running by performing the start operation again after the dialog box disappears.

Select "NO" when not executing the job with the "SIM" status.
Cancel the "SIM" status after the dialog box disappears.

2. If any of the external input signal is set to "SIM", the confirmation dialog box appears when operating the manipulator (JOG, FWD/BWD operations) with the programming pendant.

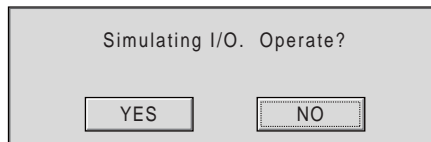

Select "YES" when operating the manipulator with the "SIM" status.
The manipulator can be operated after the dialog box disappears.
Select "NO" when not operating the manipulator with the "SIM" status.
Cancel the "SIM" status after the dialog box disappears.

13.2.5.1 Batch Selection of SIM

Follow the procedure below to set all the external input signals to "SIM".

1. Display the EXTERNAL INPUT window.

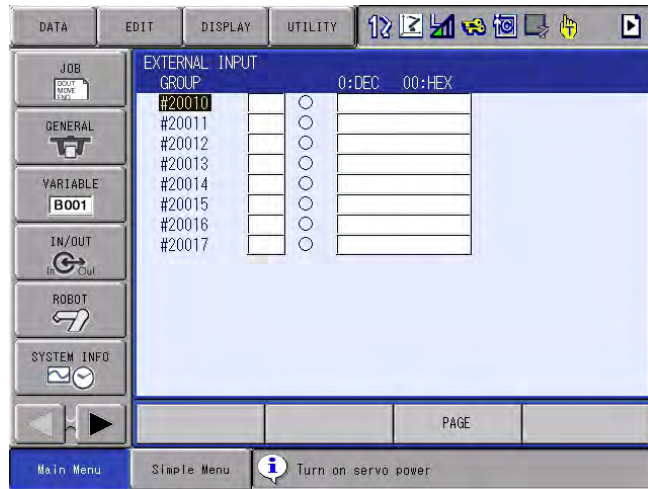

2. Select {EDIT} from the menu.

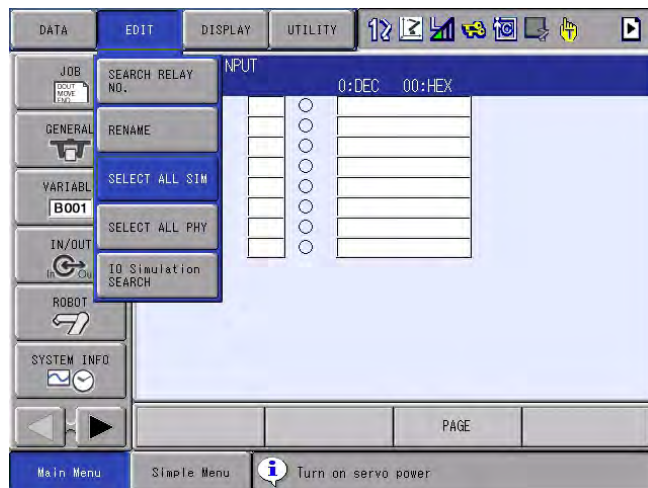

3. Select {SELECT ALL SIM}.

– Set all the external input signals to "SIM".

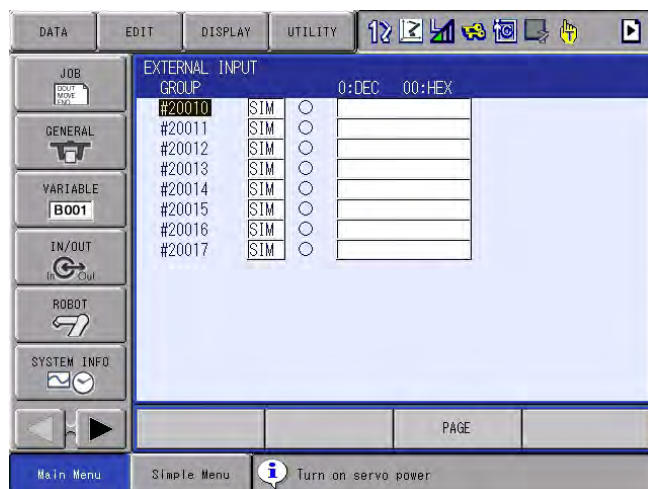

13.2.5.2 Batch Cancellation of SIM

Follow the procedure below to cancel the “SIM” status of all the external input signals.

1. Display the EXTERNAL INPUT window.

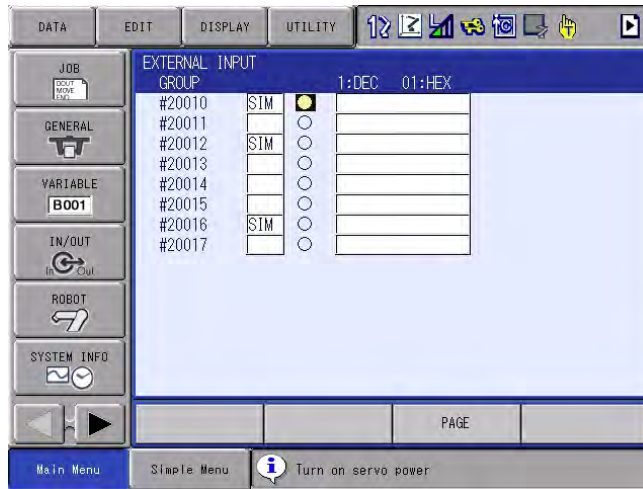

2. Select {EDIT} from the menu.

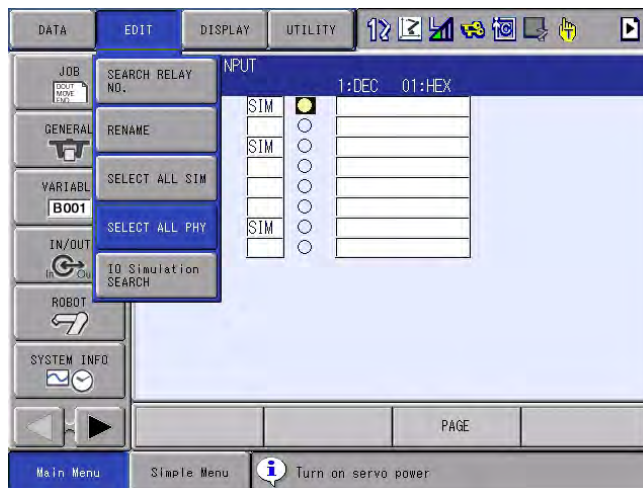

3. Select {SELECT ALL PHY}.

- Cancels the “SIM” status of all the external input signals.

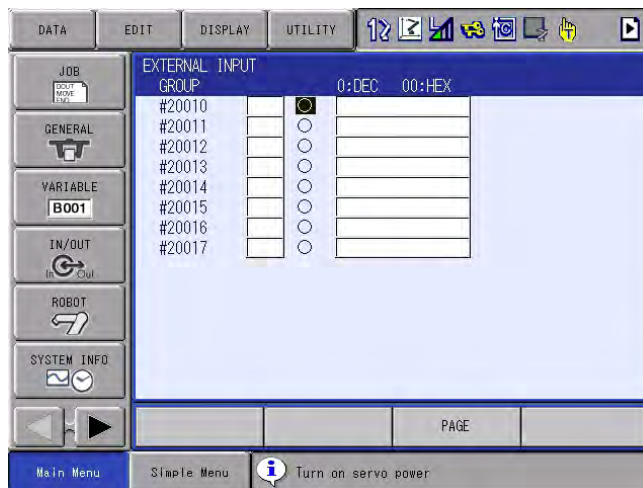

13.2.5.3 IO Simulation Search

Follow the procedure below to search the external input signals with “SIM” status.

1. Display the EXTERNAL INPUT window.

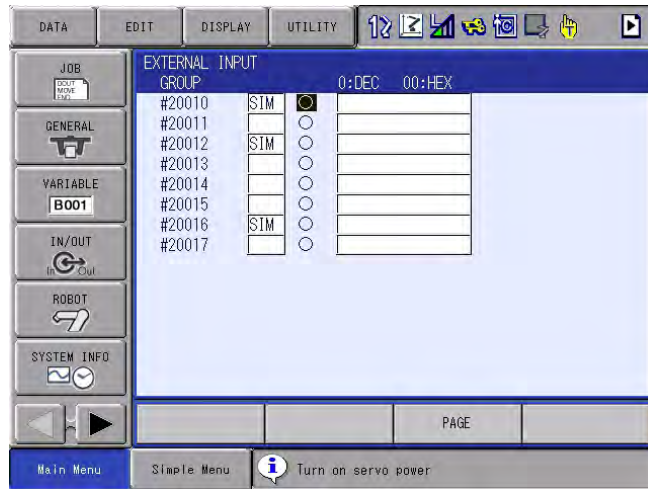

2. Select {EDIT} from the menu.

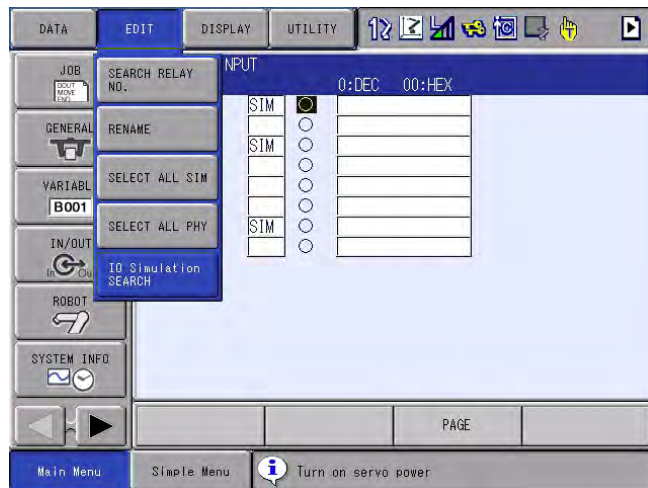

3. Select {IO Simulation SEARCH}.

– When there is an external input signal with “SIM” status, the following is shown:

- (1) “■” are added on the left of the signals with the “SIM” status.
- (2) “(IO Simulation Search)” is shown in the title.

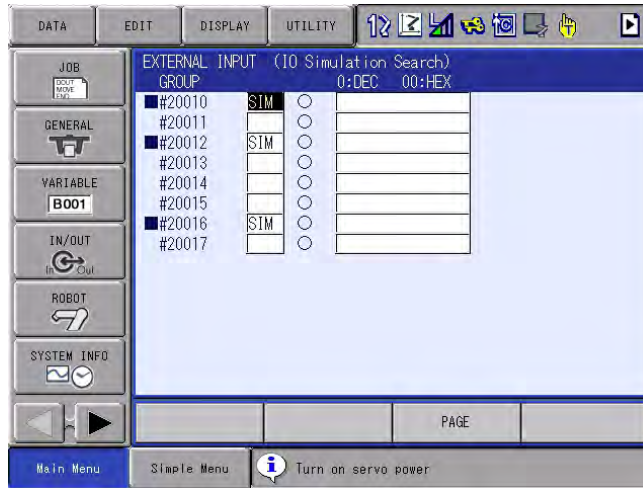

– When there is no external input signal with “SIM” status, the following is shown:

- (1) “ERROR 2050: Address not found” is shown.
- (2) Does not move on to the IO simulation search.

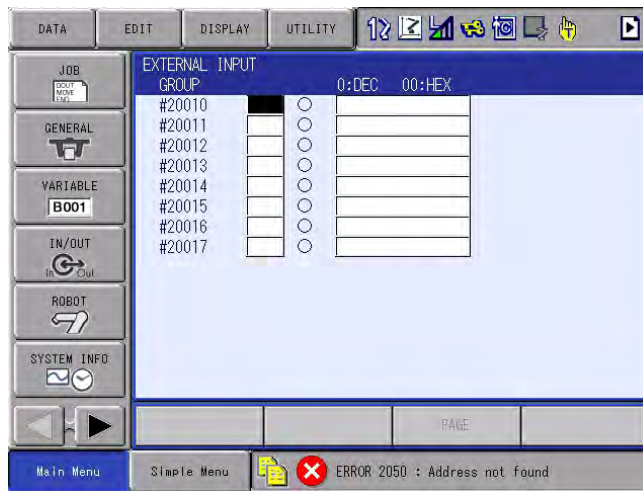

 During the IO simulation search, the search status does not change even if the signal's “SIM” status changes. “■” is added to the signal which was “SIM” status when the search started.

Follow the procedure below to jump to the external input signal with “SIM” status during the IO simulation search.

1. Press the cursor key [↓].
 - The cursor moves to the next signal with “SIM” status.
2. Press the cursor key [↑].
 - The cursor moves to the previous signal with “SIM” status.

The IO simulation search is cancelled in the following cases:

- when [CANCEL] is pressed during the IO simulation search
- when the menu {EDIT}, then {SELECT ALL SIM} are selected during the IO simulation search
- when the menu {EDIT}, then {SELECT ALL PHY} are selected during the IO simulation search
- when the menu {EDIT}, then {SEARCH SIGNAL NO.} or {SEARCH RELAY NO.} are selected during the IO simulation search
- when the display is changed from the I/O status window (DETAIL) to the I/O window (SIMPLE)
- when the window is closed
- when the page is switched

13.3 Pseudo Input Signal Window

13.3.1 Checking Pseudo Input Signal Status

The status and name of the pseudo input signals can be checked with this window.

1. Select {IN/OUT} under the main menu.
2. Select {PSEUDO INPUT SIG}.
- The pseudo input signal window appears.

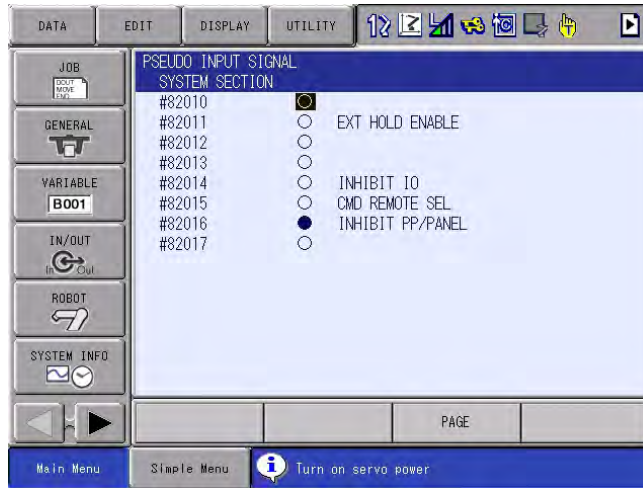

3. Press the PAGE key .
 - The system section (#82010-#82167) and the user section (#82170-#82207) are changed alternately by pressing the PAGE key





13.3.2 Changing Pseudo Input Signal Status

The signals can be turned ON/OFF in the pseudo input signal window in the management mode.

The status of the pseudo input signals can be changed by performing the following procedure.

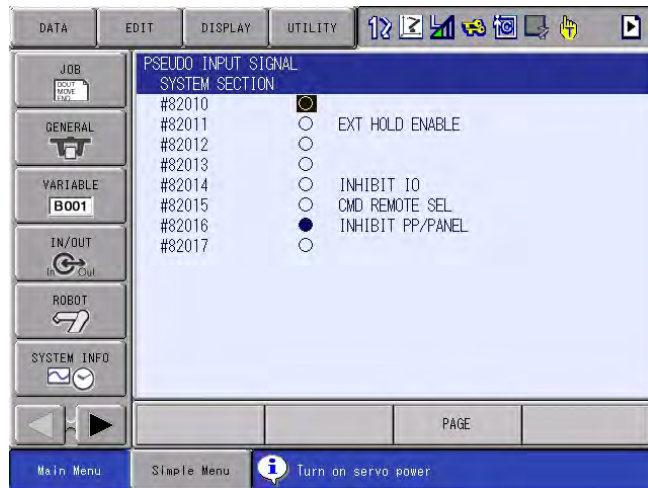
1. Select the signal to be changed.
 - Move the cursor to the signal status to be changed. The signal status is indicated as either “○” or “●”.



2. Select the signal status.
 - The signal status changes each time the INTERLOCK key  +[SELECT] are pressed. (● : ON; ○ : OFF).



The signal #82011 EXT HOLD ENABLE can also be set in {OPERATE ENABLE} under the main menu {SETUP} in the management mode.
(Refer to “FS100 Instructions (RE-CTO-A218) 13.6.3 Input/Output Connector (CN1, CN2) and 13.7.3 Input/Output Connector (CN1, CN2)”.)

13.3.3 Registering Signal Name

Signal name can be registered in the user section of the pseudo input signal window in the management mode.

The signal name can be registered by performing the following procedure.

1. Select the signal name to be changed.
 - (1) Move the cursor to the desired signal name to be registered, and press [SELECT] to enable character entry.
 - Enter up to 8 one-byte characters.

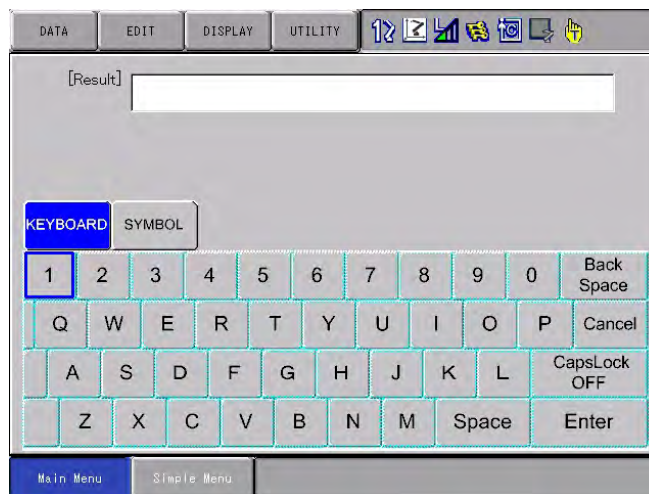

2. Input the signal name.

3. Press [ENTER].

(1) Input the signal name and press [ENTER].

– The name is registered.

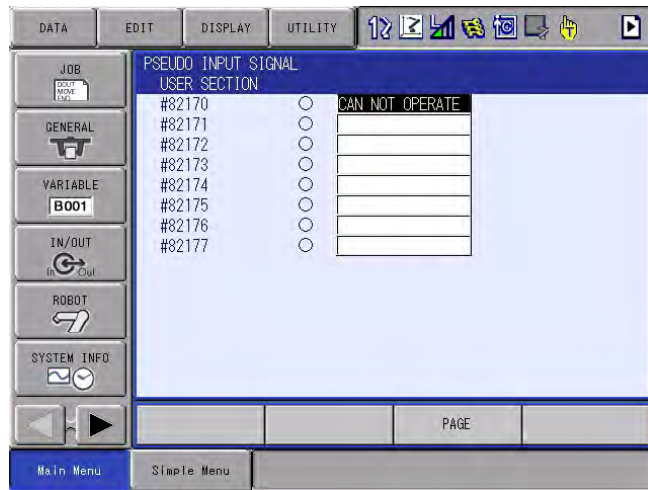

13.4 Register Window

13.4.1 Checking Register

The register can be checked in the register window.

1. Select {IN/OUT} under the main menu.
 2. Select {REGISTER}.
- The register window appears.

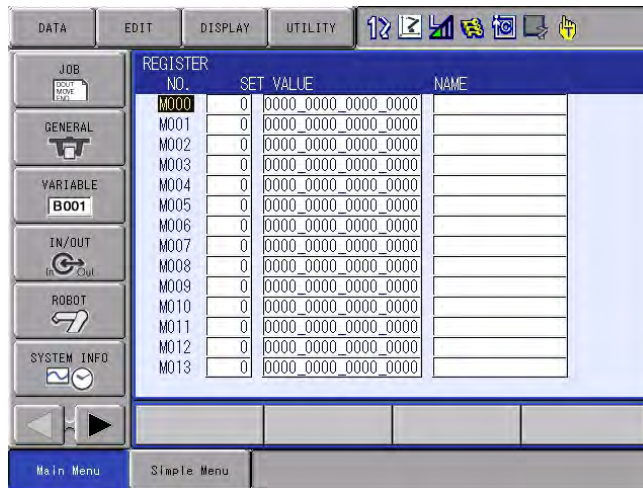

3. Move the cursor to the desired register number.
- When the desired register number is not displayed, move the cursor in the following manner: move the cursor to “NO.” and press [SELECT]; enter the desired register number using the numeric keys, then press [ENTER].
 The cursor moves to the specified register number.

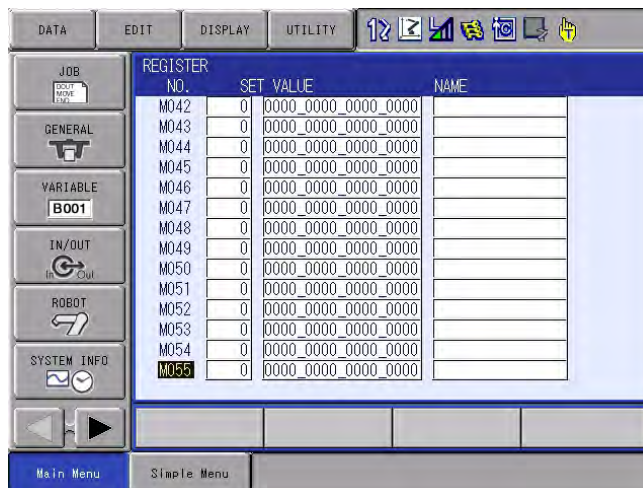

13.4.2 Setting Register

A register can be set in the management mode.

1. Select the register data to be set.
 - (1) Move the cursor to the data (decimal or binary) of the register number to be set in the register window, and press [SELECT].
 - When the decimal data is selected, enter a decimal value.
 - When the binary data is selected, enter a binary value.

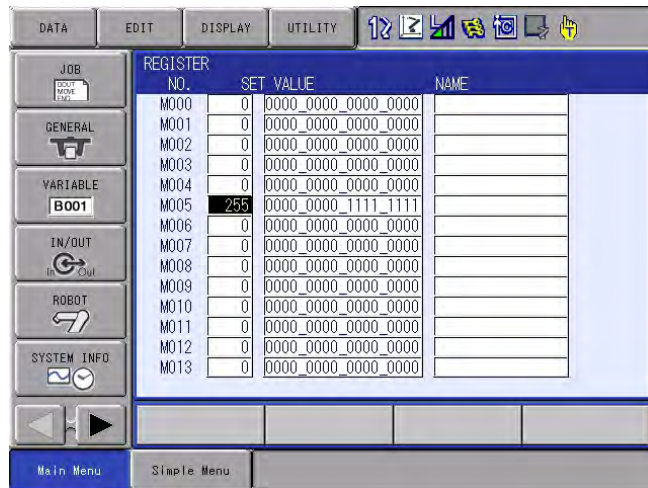

2. Enter a desired numerical value.
 - When a decimal value is selected, enter decimal value data using the numeric keys.

M005 ← Enter data with the numeric keys

- When a binary value is selected, move the cursor to a binary data to be set in the input line, and press [SELECT]. Each time [SELECT] is pressed, “0” and “1” are displayed alternately. Also, “0” and “1” can be entered using the NUMBERKEYS.

M005

0	0	0	0	0	0	0	0
0	1	1	1	1	1	1	1

↑
Change values (1 ↔ 0) with the SELECT key

3. Press [ENTER].

– The entered numerical value is set at the cursor position.

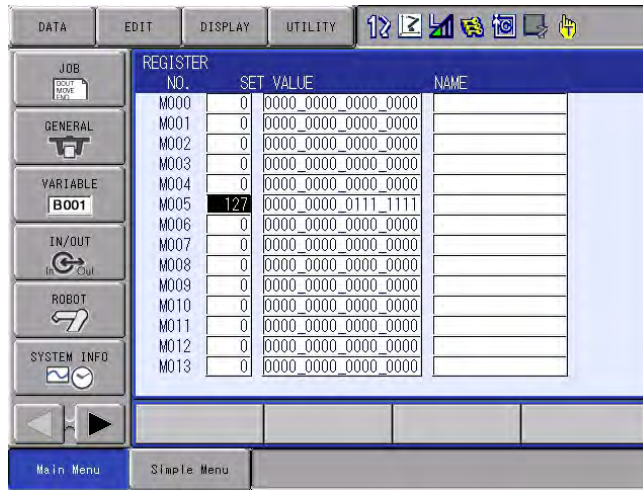

The registers used as current value of TMR/CNT/MLTMR instruction in the ladder program cannot be set.

<Example of Ladder Program>

STR #70010	←	M010 (current value) cannot be set in the register window;
TMR M010, M011		(set value) can be set in the register window.
OUT #70011M011		
STR #70020	←	M020 (current value) cannot be set in the register window;
STR #70021		(set value) can be set in the register window.
CNT #M020, M021		
OUT #70021M021		

13.4.3 Registering Signal Name

The signal name can be registered by performing the following procedure.

1. Select the signal name to be registered.
 - (1) Move the cursor to the desired signal name to be registered, and press [SELECT] to enable character entry.
 - Enter up to 16 one-byte (or 8 two-byte) characters.

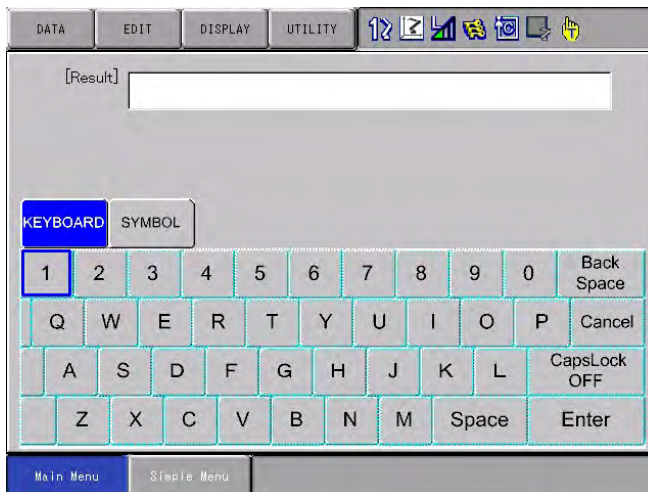
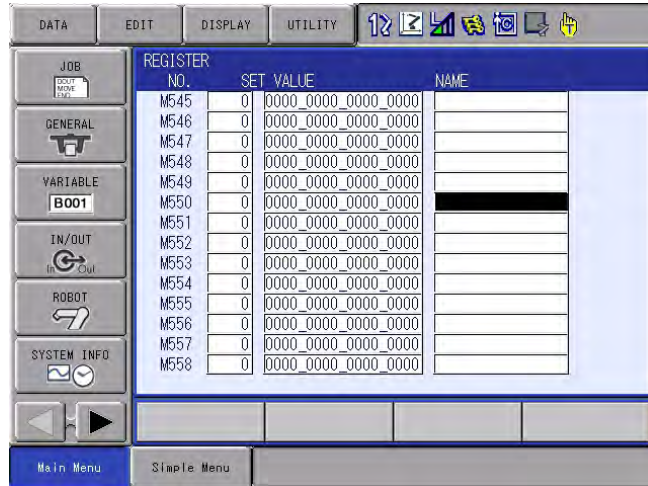

2. Enter the signal name.

3. Press [ENTER].
 - (1) Input the signal name and press [ENTER].
 - The name is registered.

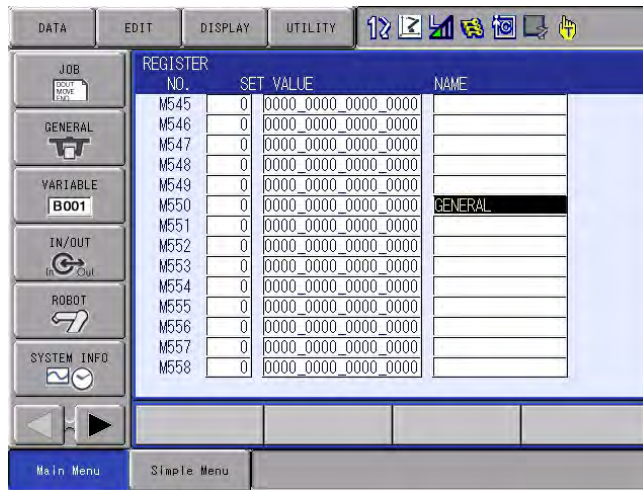

13.5 Analog Output Window

The current settings can be checked in the Analog Output window.

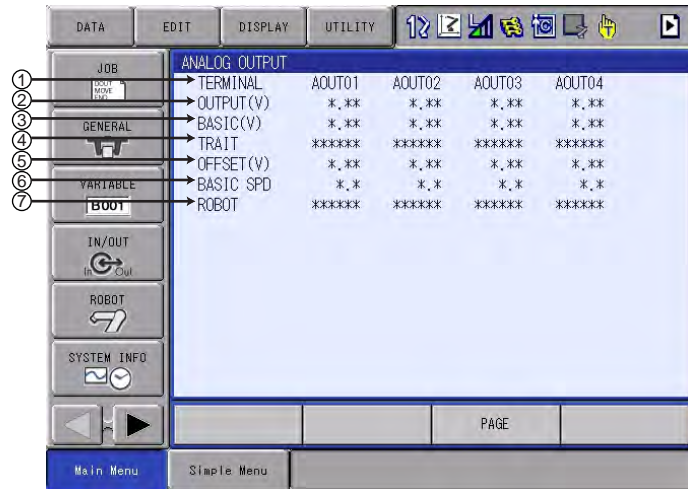

① TERMINAL

The general-purpose analog output ports are displayed.

② OUTPUT (V)

The current output voltage is displayed.

③ BASIC (V)

The basic voltage used for executing the analog output corresponding to speed is displayed.

The value can be overwritten by setting a new value using ARATION instruction.

④ TRAIT

The current output characteristic of output port is displayed.

SP RAT: Executing analog output corresponding to speed.

STATIC: The output is fixed.

⑤ OFFSET (V)

The offset voltage used for executing the analog output corresponding to speed is displayed.

The value can be overwritten by setting a new value using ARATION instruction.

⑥ BASIC SPD

The basic speed used for executing the analog output corresponding to speed is displayed.

The value can be overwritten by setting a new value using ARATION instruction.

⑦ ROBOT

The manipulator No. for the analog output corresponding to speed is displayed.

13.5.1 Operating Procedure

1. Select {IN/OUT} under the main menu.
2. Select {ANALOG OUTPUT}.
 - The analog output window appears.
 - The window for the output terminal AOUT1 to 4, AOUT 5 to 8, and AOUT 9 to 12 can be switched by pressing the PAGE key .



13.6 I/O Messages and I/O Alarms

13.6.1 Displaying User Section

User section I/O alarms and I/O messages can be displayed or registered in the management mode by the following procedures:

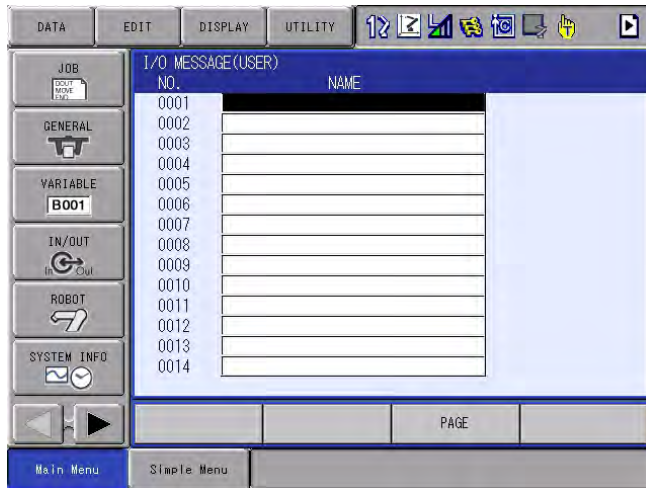
1. Select {IN/OUT} under the main menu.
2. Select {IO ALARM} or {IO MESSAGE}.
 - The user section or the system section under the selected submenu (I/O Alarm or I/O Message) is displayed.



3. Press the PAGE key .
 - To change between the user section and the system section, use the PAGE key .

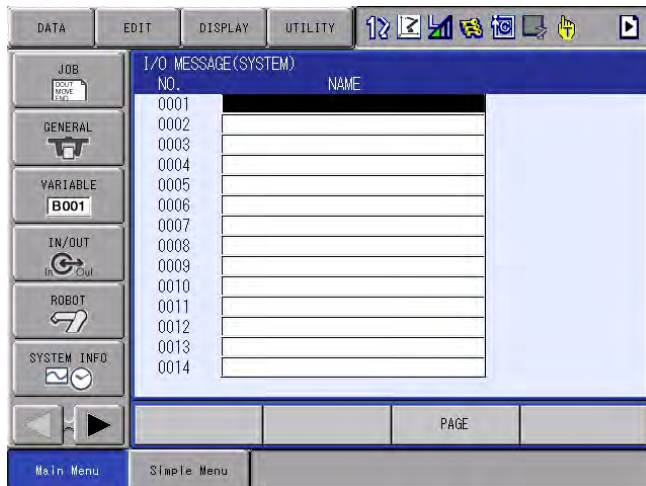

13.6.2 Registering User Section

User section I/O alarms and I/O messages can be displayed or registered by the following procedures.

However, the system I/O alarms and I/O messages cannot be edited.

1. Select the name to be changed.
 - (1) Move the cursor to the name to be changed in either the I/O Alarm (User Section) window or the I/O Message (User Section) window, and press [SELECT].
 - (2) The character input status window appears.
 - Enter up to 32 one-byte characters for the Alarm and Message windows respectively.
 - Up to 8 messages can be registered for each window.

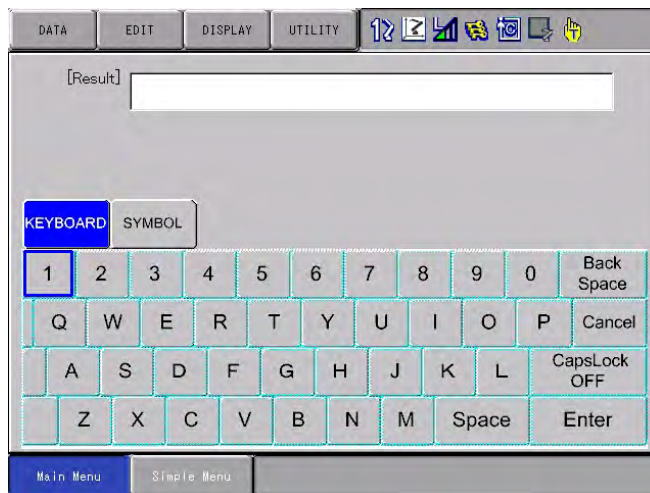

2. Input the I/O Alarm Name or the I/O Message Name.
3. Press [ENTER].
 - (1) Enter the name in the input line, and press [ENTER].
 - The name is displayed.

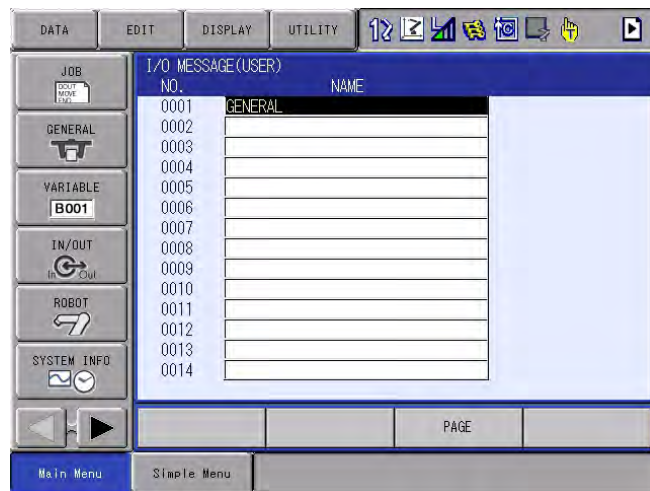

13.7 Ladder Program Window

This window allows operators to check the ON-OFF status of signals and register values included in the ladder program.

Set the security mode to the management mode.

(The {LADDER PROGRAM} menu is not displayed in the operation/edit mode.)

1. Select {IN/OUT} from the main menu.
2. Select {LADDER PROGRAM}.
 - The ladder program window appears.

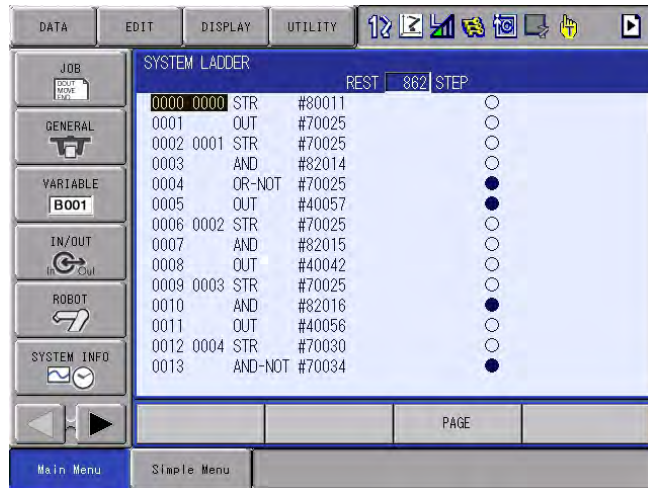

The programming pendant will not display the monitor indication while the ladder program is edited.

The monitor indication restarts if compiling the edited ladder program succeeds and ends with a normal termination.

The monitor indication may be displayed differently depending on the instruction types of ladder program.

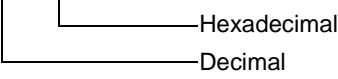
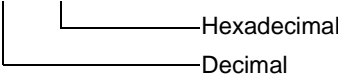
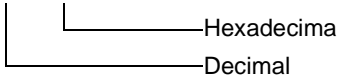
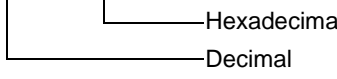
Instruction	Description
STR OR AND OUT PLS PLF	<p>“●” signifies the ON status of operand relay number signal. “○” signifies the OFF status of operand relay number signal.</p> <p><Example> STR #20010 ● : #20010=ON-status</p>
STR-NOT OR-NOT AND-NOT	<p>“●” signifies the OFF status of operand relay number signal. “○” signifies the ON status of operand relay number signal.</p> <p><Example> STR-NOT #20010 ● : #20010=OFF-status</p>
GSTR GOUT	<p>Indicates the 8 bit data value from the operand relay number in the decimal/hexadecimal number. (The value in parentheses indicates the hexadecimal number.)</p> <p><Example> GOUT #00010 128 (80H)</p>  <p>In this case, #00010 to #00016=OFF-status, and #00017=ON-status.</p>
CNT TMR MLTMR	<p>Indicates the register value (16 bits) of the current value operand (the 1st operand) in the decimal/hexadecimal number. (The value in parentheses indicates the hexadecimal number.)</p> <p><Example> TMR M010, M011 10 (000aH)</p>  <p>In this case, setting is M010=10.</p>
ADD SUB DIV MOD	<p>Indicates the register value (16 bits) of the calculation result operand (the 3rd operand) in the decimal/hexadecimal number. (The value in parentheses indicates the hexadecimal number.)</p> <p><Example> ADD M020, M021, M022 100 (0064H)</p>  <p>In this case, setting is M022=100.</p>
MUL	<p>Indicates the register value (16 bits) of the calculation result operand (the 3rd operand) in the decimal/hexadecimal number. (The value in parentheses indicates the hexadecimal number.) However, if the calculation result exceeds 16 bits, the register value will be indicated in 32-bit value in the decimal/hexadecimal number.</p> <p><Example> MUL M030, M031, M032 65536 (00010000H)</p>  <p>In this case, setting is M032=65536.</p>

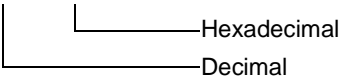
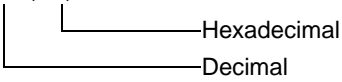
Instruction	Description
WAND WOR WXOR SHL SHR ROL ROR	<p>Indicates the value of the register/word-type relay/byte type relay of the calculation result operand (the 3rd operand) in the decimal/hexadecimal number. (The value in parentheses indicates the hexadecimal number.)</p> <p>Register, word-type relay: 16 bits Byte-type relay: 8 bits</p> <p><Example> SHL M040, 4, M041 4096 (1000H)</p>  <p>In this case, setting is M041=4096.</p>
WNOT MOV BIN BCD	<p>Indicates the value of the register/word-type relay/byte type relay of the calculation result operand (the 2nd operand) in the decimal/hexadecimal number. (The value in parentheses indicates the hexadecimal number.)</p> <p>Register, word-type relay: 16 bits Byte-type relay: 8 bits</p> <p><Example> MOV 255, #70010 255 (ffH)</p>  <p>In this case, #70010 to #70017=ON-status.</p>
AND-STR OR-STR END (PART) (NOP)	<p>The monitor indication will not be displayed.</p>

13.8 IO Simulation List Window

In the IO simulation list window, the list of the signals with “SIM” status can be displayed. The following three signals, which “SIM” status can be set, are displayed in the IO simulation list window:

- User input
- External output
- External input

Follow the procedure below to display the IO simulation list window.

1. Select {IN/OUT} under the main menu.



2. Select {IO SIMULATION LIST}.

– The IO simulation list window of the user input is displayed.

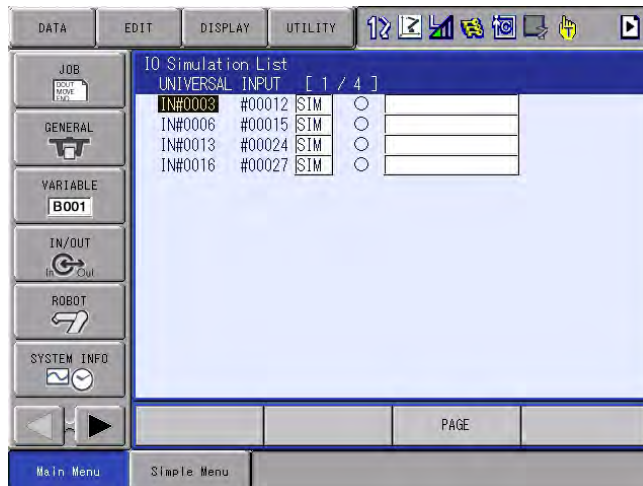

3. Press the PAGE key .

- The IO simulation list window is displayed in the order of “EXTERNAL INPUT -> EXTERNAL OUTPUT -> UNIVERSAL INPUT-> EXTERNAL INPUT -> ...”.
- If there is no signal with “SIM” status, the following window is displayed.

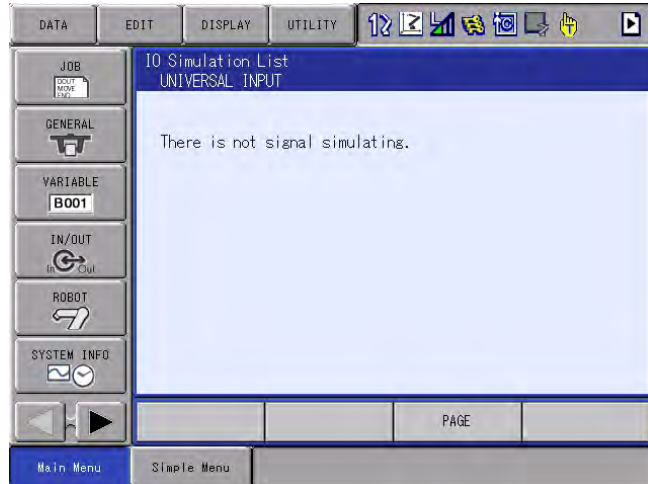

In the IO simulation list window, only the signals with “SIM” status are displayed.



If the “SIM” status of a signal is cancelled while the IO simulation list window is displayed, the signal disappears from the window.

14 Editing Ladder Programs

14.1 Flow of Data by Ladder Programs

Flow of data in editing, storage, and execution areas by operation of ladder program is shown below.

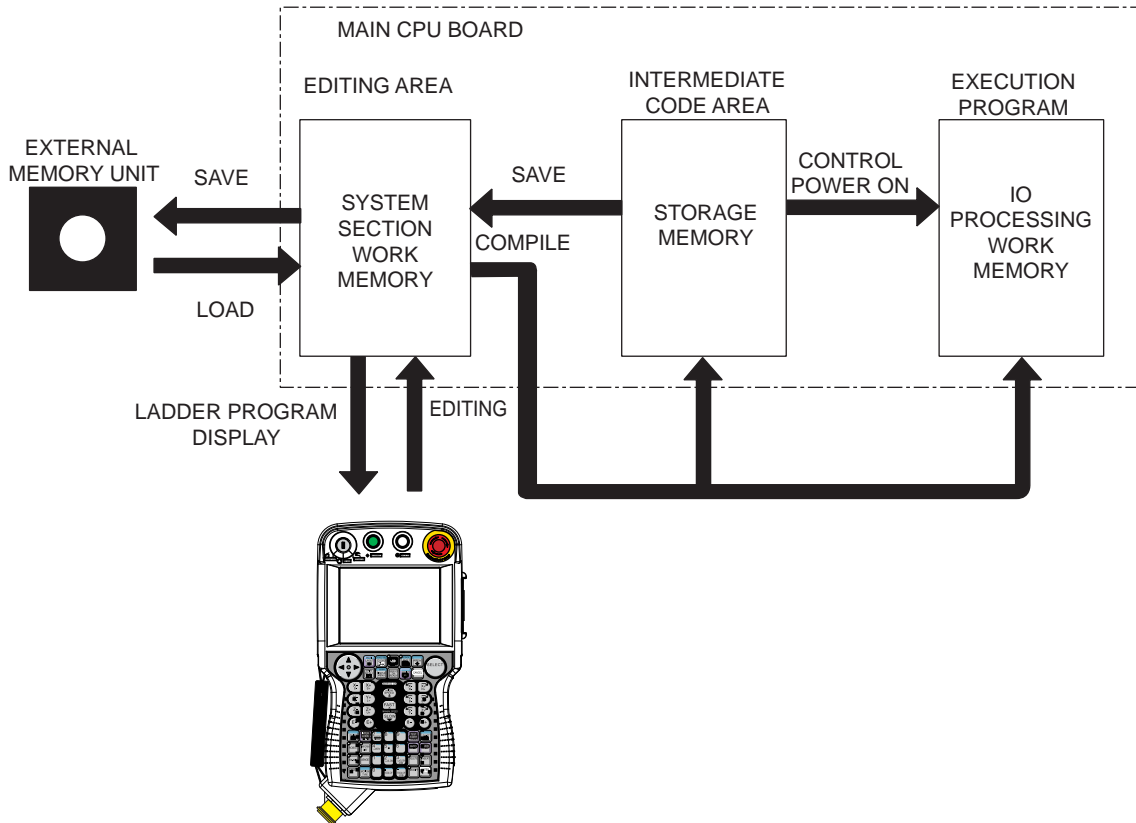

NOTE

- Only the user ladder program can be edited. The system ladder program cannot be edited.
- When the system ladder program is changed, the ladder program from the external memory unit cannot be loaded.
- If control power is shut down while the ladder program is being edited, the edited ladder program is lost. The intact program remains in the execution area.
- During editing of ladder programs, "EDITING" is displayed on the upper right of the user section window. This indication appears only when the program in the editing area and that in the execution area do not match. Nothing is displayed after compilation or cancellation of editing when the programs in the two areas match.

14.2 Editing by Mnemonic and Ladder Editor Program

The editing operations for ladder programs are two ways as follows.

1. Editing by Mnemonic Codes

- Ladder programs can be edited in mnemonic codes as shown below.

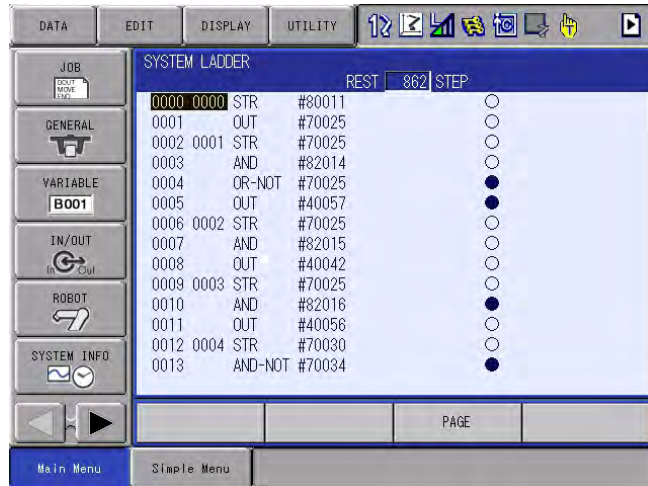

2. Ladder Editor Program (Optional Function)

- Ladder programs can be edited with the image of ladders as shown in the window below.



14.3 Mnemonic Editing Window

14.3.1 Basic Operation

Ladder program is protected so that it cannot be easily changed.

The following operations are authorized only to those who can input a user ID No. (security: management mode).

1. Select {IN/OUT} under the main menu.
2. Select {LADDER PROGRAM}.
 - The C.I/O user section is displayed.
 - To confirm the system ladder program, press the PAGE key , or select [DISP]→[SYSTEM LADDER] under the menu.

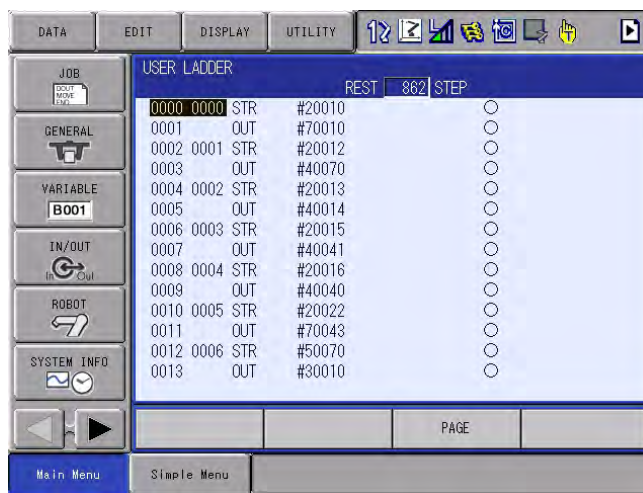

3. Edit Operation

- For each editing operations, see *Section 14.3.2 “Editing Operation”* on the following pages.
- The system ladder program cannot be edited.

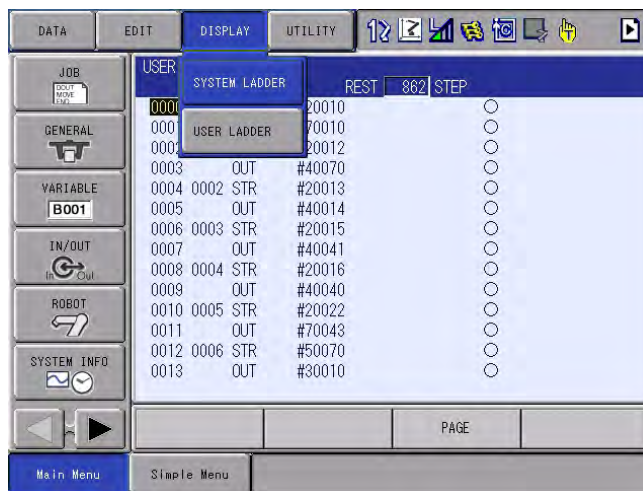

4. Select {DATA} under the menu.
5. Select {COMPILE}.

6. Select "YES".

- The edited ladder program is checked for syntax error. If no error is found, the new program is written into the execution area to run.
- If any error is found in the edited ladder program, the erroneous step is identified. In this case, the program stored in the execution area remains unchanged.

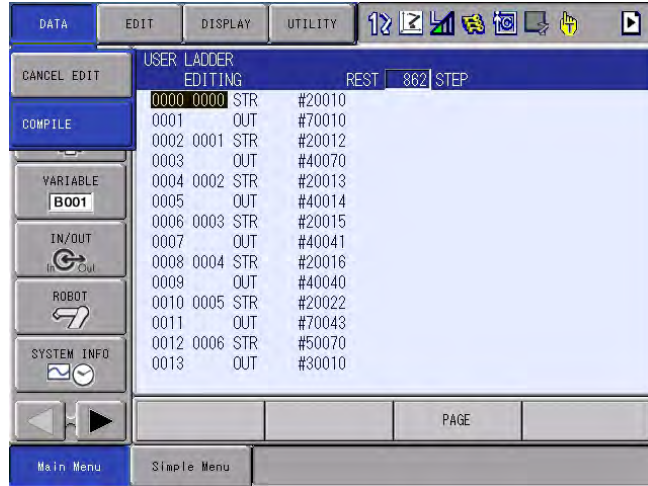

NOTE The cursor moves up/down by line each time the up/down cursor key is pressed.

Pressing the SHIFT key  + up/down cursor key moves the cursor up/down by five lines at a time.

14.3.2 Editing Operation

The editing operation is divided into the instruction registration operation (adding, changing, and deleting) and the operand edit operation.

14.3.2.1 Inserting Instruction

1. Move the cursor to the address area.

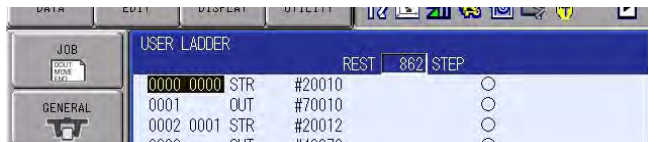

2. Select the line before the line you wish to add.
 - (1) The instruction list dialog box is displayed.
 - (2) Move the cursor to the instruction list dialog, and the cursor in the address area becomes underlined.



3. Select the instruction to be inserted.
 - Move the cursor to the input buffer line instruction.



- When there are more than two kinds of operand instructions, move the cursor to the instruction and press [SELECT]. A detailed screen is displayed.
- When changing numeric data, move the cursor to the data to be corrected and press the SHIFT key + cursor key simultaneously. The numeric data then increases and decreases.



- To directly input the numeric value, press [SELECT]. The input line is displayed, then input the data using the numeric keys and press [ENTER].



- Instructions with Two or More Kinds of Operands
The input line is displayed. Input the data using the numeric keys and press [ENTER].
 - Instructions with Two or More Kinds of Operands
- (1) When changing the type of operand, move the cursor to the operand and press [SELECT] to select the operand type.

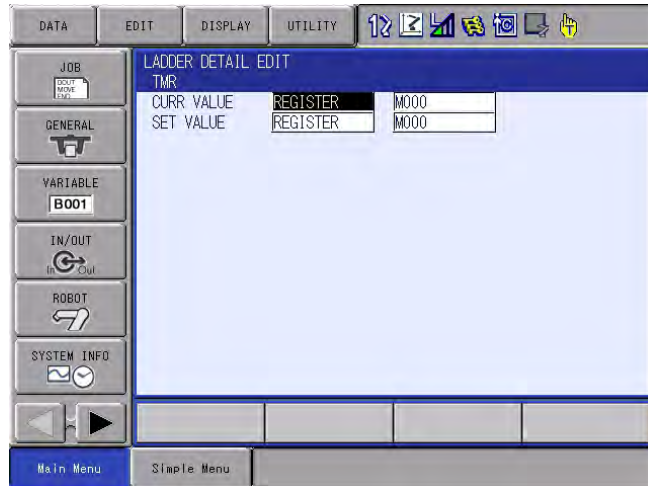

- (2) Move the cursor to the operand data and press [SELECT] to change the operand.



- (3) If the type of operand and data are changed, press [ENTER].
- (4) The ladder detail edit window closes, and the ladder program window is displayed.

4. Press [INSERT].

5. Press [ENTER].

- The instruction indicated in the input buffer line is added.
- When adding an instruction just before the END instruction, do not press [INSERT].
- If there is a change, press [SELECT] in the instruction area, and repeat the numeric input operation.

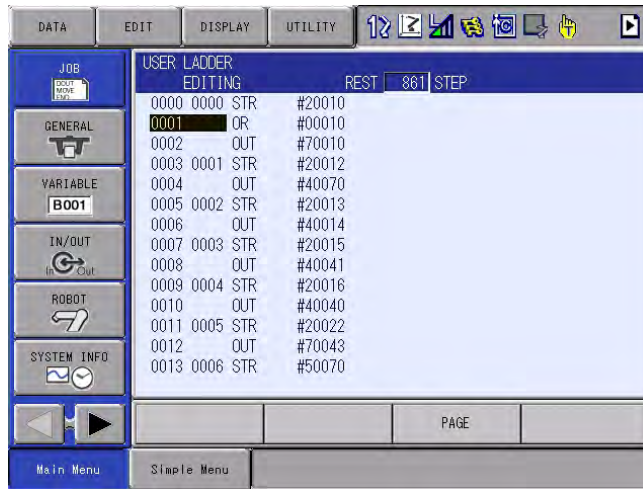

14.3.2.2 Changing Instruction

1. Move the cursor to the address area.

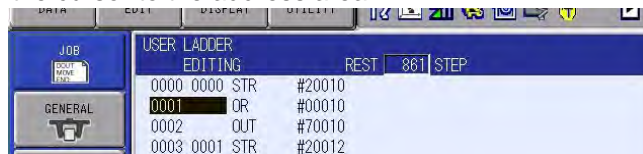

2. Select the line to be changed.

- The instruction select dialog box is displayed.
- The cursor moves to the instruction list, and the cursor in the address area is underlined.

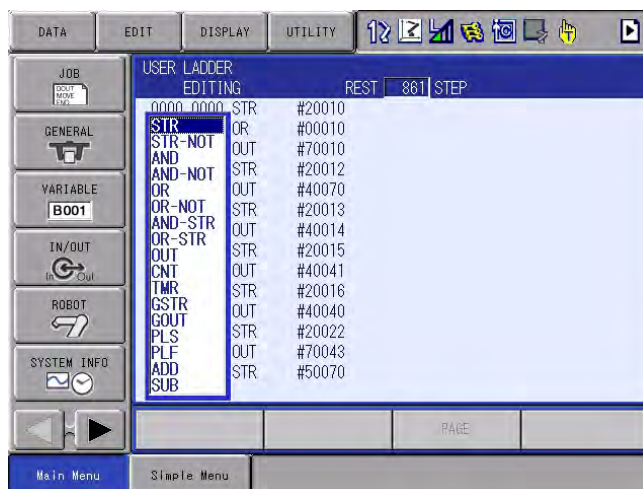

3. Select the instruction to be changed.

- Move the cursor to the input buffer line instruction.



- When there are more than two kinds of operand instructions, move the cursor to the instruction and press [SELECT]. A detailed screen is displayed.
- When changing numeric data, move the cursor to the data to be corrected and press the SHIFT key  + cursor key simultaneously. The numeric data then increases and decreases.



- (1) To directly input the numeric value, press [SELECT].
- (2) The input line appears. Input the data using the numeric keys and press [ENTER].



4. Press [MODIFY].

5. Press [ENTER].

- The instruction displayed in the input buffer line is changed.

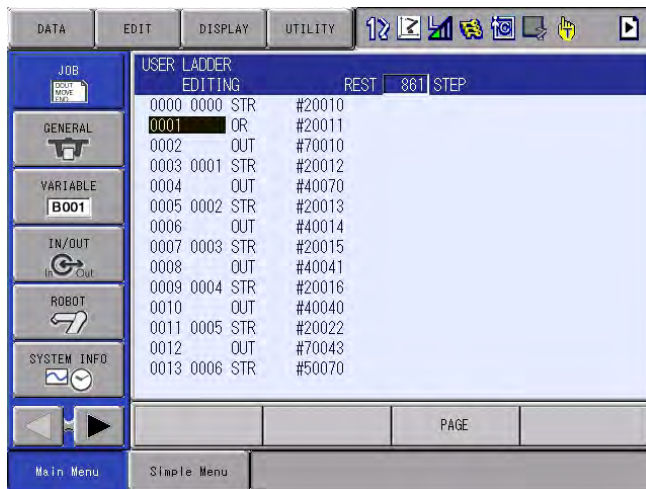

14.3.2.3 Deleting Instruction

1. Move the cursor to the address area.
2. Move the cursor to the line to be deleted.
3. Press [DELETE].
4. Press [ENTER].
 - The cursor line instruction is deleted.



14.3.2.4 Editing Operand

1. Move the cursor to the instruction area.

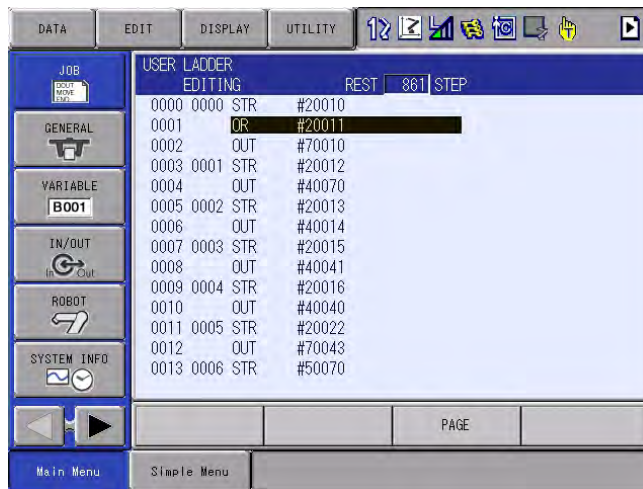

2. Select the line of the operand to be edited.
 - Move the cursor to the input buffer line instruction.

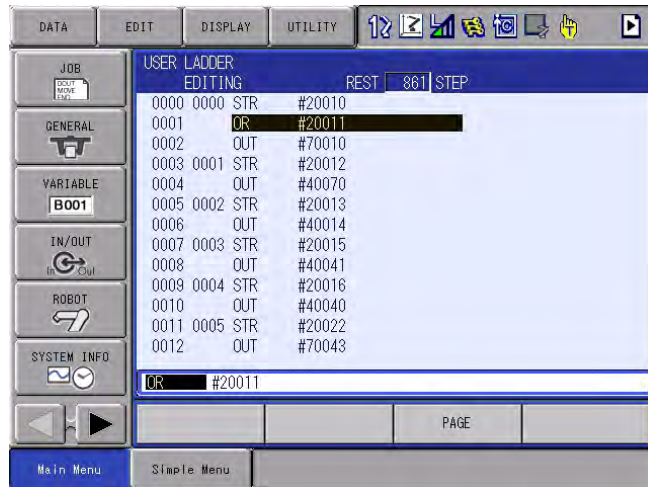

3. Edit Operation

- When there are more than two kinds of operand instructions, move the cursor in the instruction to and press [SELECT]. A detailed screen is displayed.
- When changing numeric data, move the cursor to the data to be corrected and press the SHIFT key  + cursor key simultaneously. The numeric data then increases and decreases.

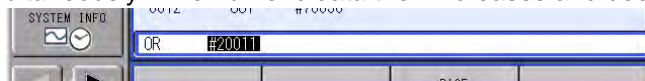

- To directly input the numeric value, press [SELECT]. The input line appears. Input the data using the numeric keys and press [ENTER].

4. Press [ENTER].
 - The cursor line operand is changed.

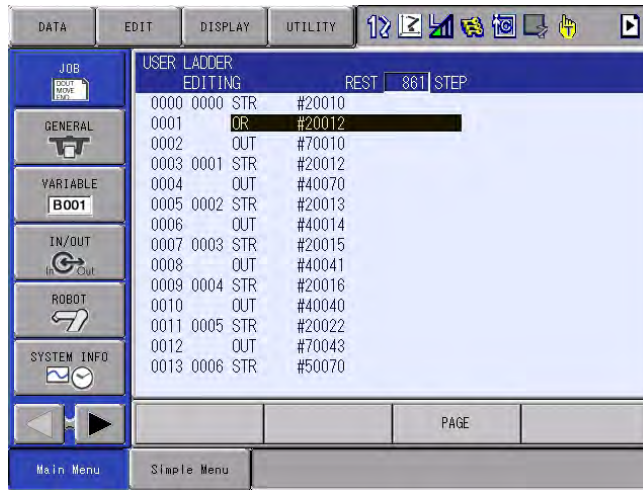

14.3.2.5 Cancelling Editing

Use the following steps to cancel editing during the ladder program editing and to return to the preceding program.

1. Select {DATA} under the menu.
2. Select {CANCEL EDIT}.
3. Select "YES".
 - The confirmation dialog box is displayed.
 - When "YES" is selected, the program returns to the ladder program (executing program) before editing.
 - When "NO" is selected, the cancel edit operation is cancelled, and the ladder program on the edit is displayed.

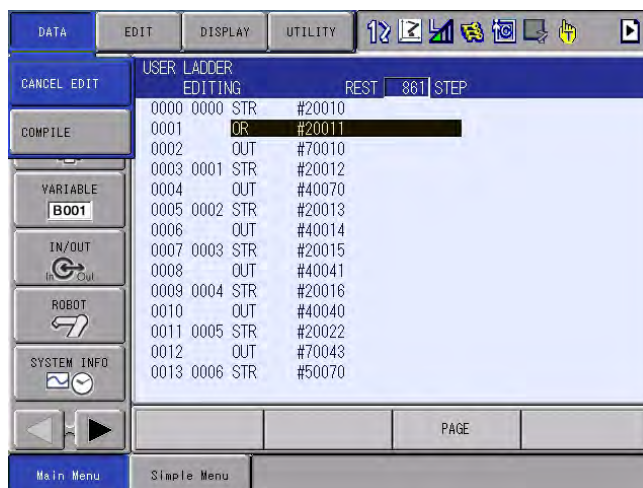

14.3.3 Compile

Use the following steps to compile the ladder program after editing.

1. Select {DATA} under the menu.
2. Select {COMPILE}.
 - The ladder program starts compiling.
 - The edited ladder program is checked for syntax error. If no error is found, the new program is written into the execution area to run.
 - If any error is found in the edited ladder program, the erroneous step is identified. In this case, the program stored in the execution area remains unchanged.

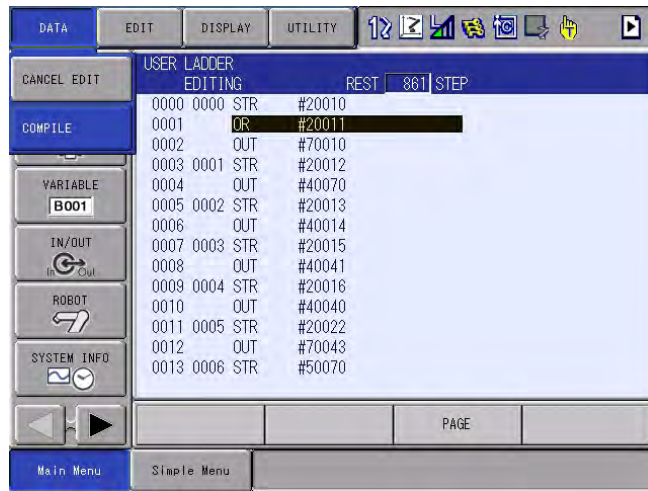

After completing the compilation, the current values of the TMR/CNT/MLTMR instructions in the register are restored to the set values.

14.3.4 Search

The search function can be used for the edit and confirmation.

Search can be executed when the cursor is either in the address area, or the instruction area of the user ladder window or the system ladder window.

The search is an operation to move the cursor to a specified line or relay No. line in the ladder window. This allows to find out a target position at once without using the cursor.

1. Select {IN/OUT} under the main menu.
 - The user ladder window or the system ladder window appears.
2. Select {LADDER PROGRAM}.
 - The user ladder window or the system ladder window appears.
 - Press the PAGE key  to switch the window.
3. Select {EDIT} under the menu.
 - The pull down menu appears.

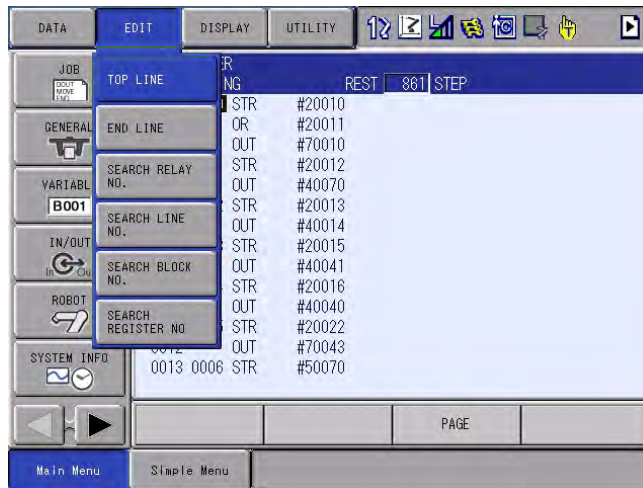

4. Select a desired search from the pull down menu.

14.3.4.1 Top Line and End Line

This is the operation to move the cursor to the first line or the last line in the current window.

1. Select "TOP LINE" or "END LINE" under the pull down menu.
 - The cursor moves to "TOP LINE" or "END LINE" of the window, then the selected line is displayed.

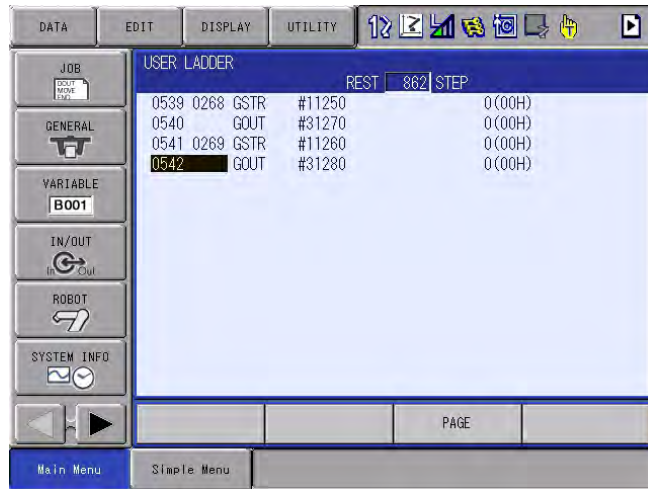

14.3.4.2 Search for Line No. and Block No.

This is the operation to move the cursor to a line or a block in the current window.

1. Select "SEARCH LINE NO." or "SEARCH BLOCK NO." under the pull down menu.
 - Numbers can be input.
2. Input a line No. or block No. using the numeric keys.
3. Press [ENTER].
 - The cursor moves to the entered line No. or block No., then the selected line or block is displayed.

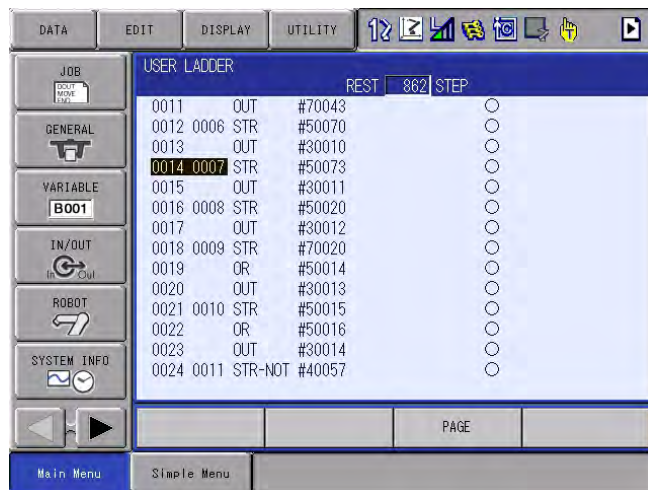

14.3.4.3 Search for Relay No. and Register No.

This is the operation to move the cursor to a relay No. or register line in the current window.

1. Select "SEARCH RELAY NO." or "SEARCH REGISTER NO." under the pull down menu.
 - Numbers can be input.
2. Input a desired relay No. or register No. using the numeric keys.
3. Press [ENTER].
 - The cursor moves to the entered relay No. or register No. and the selected relay or register is displayed.

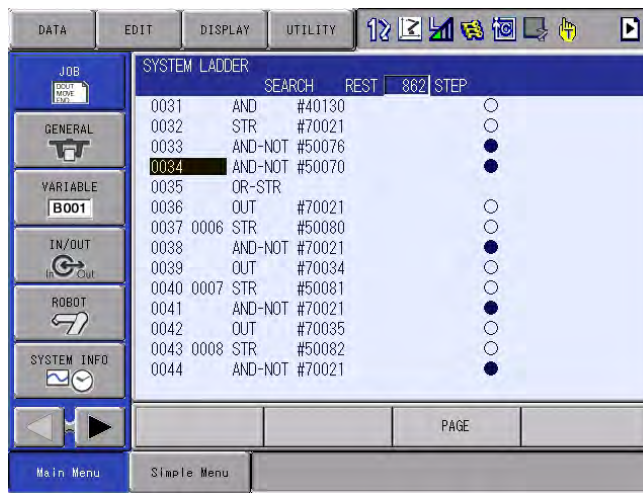

- While searching, "SEARCH" is displayed in the screen.
4. Continues searching with the cursor.
 - In search status, forward and backward searching can be executed by [↓] and [↑] cursors.
 - Press the PAGE key  to switch the window between the user ladder and the system ladder to continue searching.
 - To end the search, press [CANCEL] or move the cursor to the address area or the instruction area by using [→] and [←] cursors. The search status is cancelled and the indication of "SEARCH" disappears.

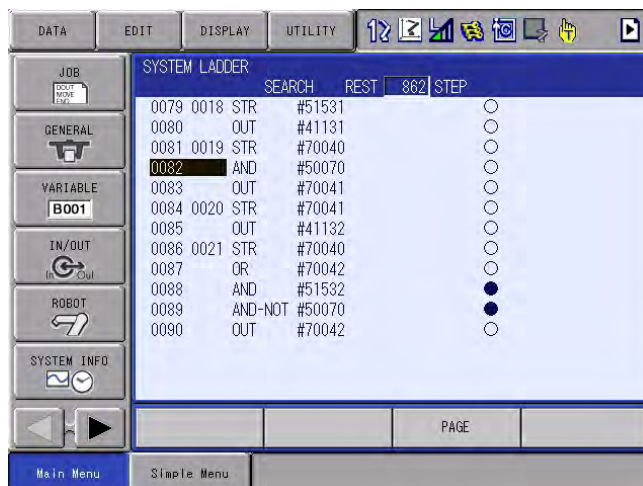

14.4 Loading Ladder Program with Different System Section

1. Select {EX.MEMORY} under the main menu.
2. Select {LOAD}.
3. Select [I/O DATA].
4. Select {UTILITY} under the menu.
5. Select {LOAD SYSTEM CIO}.
 - A check mark is added to the left of “LOAD SYSTEM CIO”.
 - The message indicating “Save current CIOPRG.LST. The CIOPRG.LST of which system ladder was changed can be loaded.” appears.

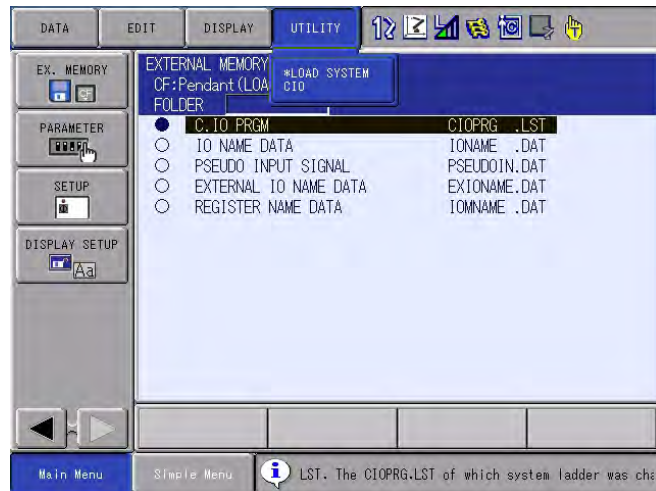

6. Select {EX.MEMORY} under the main menu.
7. Select {SAVE}.
8. Select [I/O DATA].
9. Select [C.IO PRGM].
10. Press [ENTER].
11. Select “YES”.
 - The current concurrent IO program is saved.
12. Select {EX.MEMORY} under the main menu.
13. Select {LOAD}.
14. Select [I/O DATA].
15. Select [C.IO PRGM].
16. Press [ENTER].

17. Select "YES".

- A concurrent IO program with different system section is loaded.
- The message indicating "The CIOPRG.LST of which system ladder was changed has been loaded." appears.

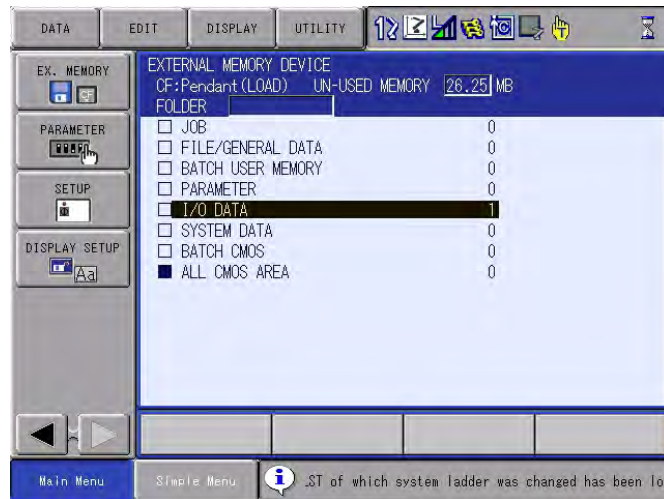

If you turn on the power supply again or change the security level while loading the ladder program with different system section, redo the above load operation from the beginning.

FS100	15	Clearing Signal
	15.1	Clearing User Output Signal

15 Clearing Signal

By setting parameters, the signal status can be automatically cleared when the power is turned ON or the mode is changed.

15.1 Clearing User Output Signal

15.1.1 Clearing Signal when Powering ON

Set the parameter S2C235 to specify whether to collectively clear the user output signals (1024 points) when powering ON, or to hold the signals in the statuses when powering OFF.

Parameter	Signal	Setting Value
S2C235	#10010 - #11287 (Collective setting)	0: Hold; 1: Clear If S2C235 is set to "1", all the statuses of the user output signals become OFF when the power is turned ON.

15.1.2 Clearing Signal when Switching Between Teach and Play Mode

Set the parameters S4C064 - S4C071 to specify whether to clear the user output signals when changing modes, or to hold the signal statuses.
 (Every 8 points; 0: hold; 1: clear)

Parameter	Signal	Setting Value
S4C064	d00: #10010 - #10017	d01: #10020 - #10027
	d02: #10030 - #10037	d03: #10040 - #10047
	d04: #10050 - #10057	d05: #10060 - #10067
	d06: #10070 - #10077	d07: #10080 - #10087
	d08: #10090 - #10097	d09: #10100 - #10107
	d10: #10110 - #10117	d11: #10120 - #10127
	d12: #10130 - #10137	d13: #10140 - #10147
	d14: #10150 - #10157	d15: #10160 - #10167
S4C065	d00: #10170 - #10177	d01: #10180 - #10187
	d02: #10190 - #10197	d03: #10200 - #10207
	d04: #10210 - #10217	d05: #10220 - #10227
	d06: #10230 - #10237	d07: #10240 - #10247
	d08: #10250 - #10257	d09: #10260 - #10267
	d10: #10270 - #10277	d11: #10280 - #10287
	d12: #10290 - #10297	d13: #10300 - #10307
	d14: #10310 - #10317	d15: #10320 - #10327
S4C066	d00: #10330 - #10337	d01: #10340 - #10347
	d02: #10350 - #10357	d03: #10360 - #10367
	d04: #10370 - #10377	d05: #10380 - #10387
	d06: #10390 - #10397	d07: #10400 - #10407
	d08: #10410 - #10417	d09: #10420 - #10427
	d10: #10430 - #10437	d11: #10440 - #10447
	d12: #10450 - #10457	d13: #10460 - #10467
	d14: #10470 - #10477	d15: #10480 - #10487
S4C067	d00: #10490 - #10497	d01: #10500 - #10507
	d02: #10510 - #10517	d03: #10520 - #10527
	d04: #10530 - #10537	d05: #10540 - #10547
	d06: #10550 - #10557	d07: #10560 - #10567
	d08: #10570 - #10577	d09: #10580 - #10587
	d10: #10590 - #10597	d11: #10600 - #10607
	d12: #10610 - #10617	d13: #10620 - #10627
	d14: #10630 - #10637	d15: #10640 - #10647

Bit specified in every 8 points
 0: Hold; 1: Clear

The user output signals whose specified bit is set to "1" will be in the "OFF" status when the mode is changed.

S4C068	d00: #10650 - #10657 d02: #10670 - #10677 d04: #10690 - #10697 d06: #10710 - #10717 d08: #10730 - #10737 d10: #10750 - #10757 d12: #10770 - #10777 d14: #10790 - #10797	d01: #10660 - #10667 d03: #10680 - #10687 d05: #10700 - #10707 d07: #10720 - #10727 d09: #10740 - #10747 d11: #10760 - #10767 d13: #10780 - #10787 d15: #10800 - #10807	Bit specified in every 8 points 0: Hold; 1: Clear <div style="border: 1px solid black; padding: 5px;"> The user output signals whose specified bit is set to "1" will be in the "OFF" status when the mode is changed. </div>
S4C069	d00: #10810 - #10817 d02: #10830 - #10837 d04: #10850 - #10857 d06: #10870 - #10877 d08: #10890 - #10897 d10: #10910 - #10917 d12: #10930 - #10937 d14: #10950 - #10957	d01: #10820 - #10827 d03: #10840 - #10847 d05: #10860 - #10867 d07: #10880 - #10887 d09: #10900 - #10907 d11: #10920 - #10927 d13: #10940 - #10947 d15: #10960 - #10967	
S4C070	d00: #10970 - #10977 d02: #10990 - #10997 d04: #11010 - #11017 d06: #11030 - #11037 d08: #11050 - #11057 d10: #11070 - #11077 d12: #11090 - #11097 d14: #11110 - #11117	d01: #10980 - #10987 d03: #11000 - #11007 d05: #11020 - #11027 d07: #11040 - #11047 d09: #11060 - #11067 d11: #11080 - #11087 d13: #11100 - #11107 d15: #11120 - #11127	
S4C071	d00: #11130 - #11137 d02: #11150 - #11157 d04: #11170 - #11177 d06: #11190 - #11197 d08: #11210 - #11217 d10: #11230 - #11237 d12: #11250 - #11257 d14: #11270 - #11277	d01: #11140 - #11147 d03: #11160 - #11167 d05: #11180 - #11187 d07: #11200 - #11207 d09: #11220 - #11227 d11: #11240 - #11247 d13: #11260 - #11267 d15: #11280 - #11287	

15.2 Clearing Interface Panel Signal

15.2.1 Clearing Signal when Powering ON

Set the parameters S4C569 - S4C572 to specify whether to clear the interface panel signals when powering ON, or to hold the signals in the statuses when powering OFF.

(Every 8 points; 0: hold; 1: clear)

Parameter	Signal	Setting Value		
S4C569	d00: #60010 - #60017	d01: #60020 - #60027	Bit specified in every 8 points 0: Hold; 1: Clear <div style="border: 1px solid black; padding: 5px; margin-top: 10px;"> The interface panel signals whose specified bit is set to "1" will be in the "OFF" status when the power is ON. </div>	
	d02: #60030 - #60037	d03: #60040 - #60047		
	d04: #60050 - #60057	d05: #60060 - #60067		
	d06: #60070 - #60077	d07: #60080 - #60087		
	d08: #60090 - #60097	d09: #60100 - #60107		
	d10: #60110 - #60117	d11: #60120 - #60127		
	d12: #60130 - #60137	d13: #60140 - #60147		
	d14: #60150 - #60157	d15: #60160 - #60167		
	S4C570	d00: #60170 - #60177		d01: #60180 - #60187
		d02: #60190 - #60197		d03: #60200 - #60207
		d04: #60210 - #60217		d05: #60220 - #60227
		d06: #60230 - #60237		d07: #60240 - #60247
		d08: #60250 - #60257		d09: #60260 - #60267
		d10: #60270 - #60277		d11: #60280 - #60287
		d12: #60290 - #60297		d13: #60300 - #60307
d14: #60310 - #60317		d15: #60320 - #60327		
S4C671	d00: #60330 - #60337	d01: #60340 - #60347		
	d02: #60350 - #60357	d03: #60360 - #60367		
	d04: #60370 - #60377	d05: #60380 - #60387		
	d06: #60390 - #60397	d07: #60400 - #60407		
	d08: #60410 - #60417	d09: #60420 - #60427		
	d10: #60430 - #60437	d11: #60440 - #60447		
	d12: #60450 - #60457	d13: #60460 - #60467		
	d14: #60470 - #60477	d15: #60480 - #60487		
S4C572	d00: #60490 - #60497	d01: #60500 - #60507		
	d02: #60510 - #60517	d03: #60520 - #60527		
	d04: #60530 - #60537	d05: #60540 - #60547		
	d06: #60550 - #60557	d07: #60560 - #60567		
	d08: #60570 - #60577	d09: #60580 - #60587		
	d10: #60590 - #60597	d11: #60600 - #60607		
	d12: #60610 - #60617	d13: #60620 - #60627		
	d14: #60630 - #60637	d15: #60640 - #60647		

15.3 Clearing Auxiliary Relay Signal

15.3.1 Clearing Signal when Powering ON

Set the parameters S4C080 - S4C095 to specify whether to clear the auxiliary relay signals when powering ON, or to hold the signals in the statuses when powering OFF.

(Every 32 points; 0: clear; 1: hold)

Parameter	Signal	Setting Value	
S4C080	d00: #70010 - #70047	d01: #70050 - #70087	Bit specified in every 32 points 0: Clear; 1: Hold <div style="border: 1px solid black; padding: 5px; margin-top: 10px;"> The interface panel signals whose specified bit is set to "1" will be in the "OFF" status when the power is ON. </div>
	d02: #70090 - #70127	d03: #70130 - #70167	
	d04: #70170 - #70207	d05: #70210 - #70247	
	d06: #70250 - #70287	d07: #70290 - #70327	
	d08: #70330 - #70367	d09: #70370 - #70407	
	d10: #70410 - #70447	d11: #70450 - #70487	
	d12: #70490 - #70527	d13: #70530 - #70567	
	d14: #70570 - #70607	d15: #70610 - #70647	
S4C081	d00: #70650 - #70687	d01: #70690 - #70727	
	d02: #70730 - #70767	d03: #70770 - #70807	
	d04: #70810 - #70847	d05: #70850 - #70887	
	d06: #70890 - #70927	d07: #70930 - #70967	
	d08: #70970 - #71007	d09: #71010 - #71047	
	d10: #71050 - #71087	d11: #71090 - #71127	
	d12: #71130 - #71167	d13: #71170 - #71207	
	d14: #71210 - #71247	d15: #71250 - #71287	
S4C082	d00: #71290 - #71327	d01: #71330 - #71367	
	d02: #71370 - #71407	d03: #71410 - #71447	
	d04: #71450 - #71487	d05: #71490 - #71527	
	d06: #71530 - #71567	d07: #71570 - #71607	
	d08: #71610 - #71647	d09: #71650 - #71687	
	d10: #71690 - #71727	d11: #71730 - #71767	
	d12: #71770 - #71807	d13: #71810 - #71847	
	d14: #71850 - #71887	d15: #71890 - #71927	
S4C083	d00: #71930 - #71967	d01: #71970 - #72007	
	d02: #72010 - #72047	d03: #72050 - #72087	
	d04: #72090 - #72127	d05: #72130 - #72167	
	d06: #72170 - #72207	d07: #72210 - #72247	
	d08: #72250 - #72287	d09: #72290 - #72327	
	d10: #72330 - #72367	d11: #72370 - #72407	
	d12: #72410 - #72447	d13: #72450 - #72487	
	d14: #72490 - #72527	d15: #72530 - #72567	

S4C084	d00: #72570 - #72607 d02: #72650 - #72687 d04: #72730 - #72767 d06: #72810 - #72847 d08: #72890 - #72927 d10: #72970 - #73007 d12: #73050 - #73087 d14: #73130 - #73167	d01: #72610 - #72647 d03: #72690 - #72727 d05: #72770 - #72807 d07: #72850 - #72887 d09: #72930 - #72967 d11: #73010 - #73047 d13: #73090 - #73127 d15: #73170 - #73207	Bit specified in every 32 points 0: Clear; 1: Hold <div style="border: 1px solid black; padding: 5px;"> The interface panel signals whose specified bit is set to "1" will be in the "OFF" status when the power is ON. </div>
S4C085	d00: #73210 - #73247 d02: #73290 - #73327 d04: #73370 - #73407 d06: #73450 - #73487 d08: #73530 - #73567 d10: #73610 - #73647 d12: #73690 - #73727 d14: #73770 - #73807	d01: #73250 - #73287 d03: #73330 - #73367 d05: #73410 - #73447 d07: #73490 - #73527 d09: #73570 - #73607 d11: #73650 - #73687 d13: #73730 - #73767 d15: #73810 - #73847	
S4C086	d00: #73850 - #73887 d02: #73930 - #73967 d04: #74010 - #74047 d06: #74090 - #74127 d08: #74170 - #74207 d10: #74250 - #74287 d12: #74330 - #74367 d14: #74410 - #74447	d01: #73890 - #73927 d03: #73970 - #74007 d05: #74050 - #74087 d07: #74130 - #74167 d09: #74210 - #74247 d11: #74290 - #74327 d13: #74370 - #74407 d15: #74450 - #74487	
S4C087	d00: #74490 - #74527 d02: #74570 - #74607 d04: #74650 - #74687 d06: #74730 - #74767 d08: #74810 - #74847 d10: #74890 - #74927 d12: #74970 - #75007 d14: #75050 - #75087	d01: #74530 - #74567 d03: #74610 - #74647 d05: #74690 - #74727 d07: #74770 - #74807 d09: #74850 - #74887 d11: #74930 - #74967 d13: #75010 - #75047 d15: #75090 - #75127	
S4C088	d00: #75130 - #75167 d02: #75210 - #75247 d04: #75290 - #75327 d06: #75370 - #75407 d08: #75450 - #75487 d10: #75530 - #75567 d12: #75610 - #75647 d14: #75690 - #75727	d01: #75170 - #75207 d03: #75250 - #75287 d05: #75330 - #75367 d07: #75410 - #75447 d09: #75490 - #75527 d11: #75570 - #75607 d13: #75650 - #75687 d15: #75730 - #75767	

S4C089	d00: #75770 - #75807 d02: #75850 - #75887 d04: #75930 - #75967 d06: #76010 - #76047 d08: #76090 - #76127 d10: #76170 - #76207 d12: #76250 - #76287 d14: #76330 - #76367	d01: #75810 - #75847 d03: #75890 - #75927 d05: #75970 - #76007 d07: #76050 - #76087 d09: #76130 - #76167 d11: #76210 - #76247 d13: #76290 - #76327 d15: #76370 - #76407	Bit specified in every 32 points 0: Clear; 1: Hold <div style="border: 1px solid black; padding: 5px;"> The interface panel signals whose specified bit is set to "1" will be in the "OFF" status when the power is ON. </div>
S4C090	d00: #76410 - #76447 d02: #76490 - #76527 d04: #76570 - #76607 d06: #76650 - #76687 d08: #76730 - #76767 d10: #76810 - #76847 d12: #76890 - #76927 d14: #76970 - #77007	d01: #76450 - #76487 d03: #76530 - #76567 d05: #76610 - #76647 d07: #76690 - #76727 d09: #76770 - #76807 d11: #76850 - #76887 d13: #76930 - #76967 d15: #77010 - #77047	
S4C091	d00: #77050 - #77087 d02: #77130 - #77167 d04: #77210 - #77247 d06: #77290 - #77327 d08: #77370 - #77407 d10: #77450 - #77487 d12: #77530 - #77567 d14: #77610 - #77647	d01: #77090 - #77127 d03: #77170 - #77207 d05: #77250 - #77287 d07: #77330 - #77367 d09: #77410 - #77447 d11: #77490 - #77527 d13: #77570 - #77607 d15: #77650 - #77687	
S4C092	d00: #77690 - #77727 d02: #77770 - #77807 d04: #77850 - #77887 d06: #77930 - #77967 d08: #78010 - #78047 d10: #78090 - #78127 d12: #78170 - #78207 d14: #78250 - #78287	d01: #77730 - #77767 d03: #77810 - #77847 d05: #77890 - #77927 d07: #77970 - #78007 d09: #78050 - #78087 d11: #78130 - #78167 d13: #78210 - #78247 d15: #78290 - #78327	
S4C093	d00: #78330 - #78367 d02: #78410 - #78447 d04: #78490 - #78527 d06: #78570 - #78607 d08: #78650 - #78687 d10: #78730 - #78767 d12: #78810 - #78847 d14: #78890 - #78927	d01: #78370 - #78407 d03: #78450 - #78487 d05: #78530 - #78567 d07: #78610 - #78647 d09: #78690 - #78727 d11: #78770 - #78807 d13: #78850 - #78887 d15: #78930 - #78967	

<p>S4C094</p>	<p>d00: #78970 - #79007 d02: #79050 - #79087 d04: #79130 - #79167 d06: #79210 - #79247 d08: #79290 - #79327 d10: #79370 - #79407 d12: #79450 - #79487 d14: #79530 - #79567</p>	<p>d01: #79010 - #79047 d03: #79090 - #79127 d05: #79170 - #79207 d07: #79250 - #79287 d09: #79330 - #79367 d11: #79410 - #79447 d13: #79490 - #79527 d15: #79570 - #79607</p>	<p>Bit specified in every 32 points 0: Clear; 1: Hold</p> <div style="border: 1px solid black; padding: 5px; margin-top: 10px;"> <p>The interface panel signals whose specified bit is set to "1" will be in the "OFF" status when the power is ON.</p> </div>
<p>S4C095</p>	<p>d00: #79610 - #79647 d02: #79690 - #79727 d04: #79770 - #79807 d06: #79850 - #79887 d08: #79930 - #79967</p>	<p>d01: #79650 - #79687 d03: #79730 - #79767 d05: #79810 - #79847 d07: #79890 - #79927 d09: #79970 - #79997</p>	

15.4 Clearing User Register

15.4.1 Clearing Register when Powering ON

Set the parameters S4C835 - 869 to specify whether to clear the user registers when powering ON, or to hold the signals in the statuses when powering OFF.

(Every 1 point; 0: hold; 1: clear)

Parameter	Signal					Setting Value
S4C835	d00: M000	d01: M001	d02: M002	d03: M003		Bit specified in every 1 points 0: Hold; 1: Clear The values of the user registers whose specified bit is set to 1 will be "0" when the power is ON.
	d04: M004	d05: M005	d06: M006	d07: M007		
	d08: M008	d09: M009	d10: M010	d11: M011		
	d12: M012	d13: M013	d14: M014	d15: M015		
S4C836	d00: M016	d01: M017	d02: M018	d03: M019		
	d04: M020	d05: M021	d06: M022	d07: M023		
	d08: M024	d09: M025	d10: M026	d11: M027		
	d12: M028	d13: M029	d14: M030	d15: M031		
S4C837	d00: M032	d01: M033	d02: M034	d03: M035		
	d04: M036	d05: M037	d06: M038	d07: M039		
	d08: M040	d09: M041	d10: M042	d11: M043		
	d12: M044	d13: M045	d14: M046	d15: M047		
S4C838	d00: M048	d01: M049	d02: M050	d03: M051		
	d04: M052	d05: M053	d06: M054	d07: M055		
	d08: M056	d09: M057	d10: M058	d11: M059		
	d12: M060	d13: M061	d14: M062	d15: M063		
S4C839	d00: M064	d01: M065	d02: M066	d03: M067		
	d04: M068	d05: M069	d06: M070	d07: M071		
	d08: M072	d09: M073	d10: M074	d11: M075		
	d12: M076	d13: M077	d14: M078	d15: M079		
S4C840	d00: M080	d01: M081	d02: M082	d03: M083		
	d04: M084	d05: M085	d06: M086	d07: M087		
	d08: M088	d09: M089	d10: M090	d11: M091		
	d12: M092	d13: M093	d14: M094	d15: M095		
S4C841	d00: M096	d01: M097	d02: M098	d03: M099		
	d04: M100	d05: M101	d06: M102	d07: M103		
	d08: M104	d09: M105	d10: M106	d11: M107		
	d12: M108	d13: M109	d14: M110	d15: M111		
S4C842	d00: M112	d01: M113	d02: M114	d03: M115		
	d04: M116	d05: M117	d06: M118	d07: M119		
	d08: M120	d09: M121	d10: M122	d11: M123		
	d12: M124	d13: M125	d14: M126	d15: M127		
S4C843	d00: M128	d01: M129	d02: M130	d03: M131		
	d04: M132	d05: M133	d06: M134	d07: M135		
	d08: M136	d09: M137	d10: M138	d11: M139		
	d12: M140	d13: M141	d14: M142	d15: M143		

S4C844	d00: M144 d04: M148 d08: M152 d12: M156	d01: M145 d05: M149 d09: M153 d13: M157	d02: M146 d06: M150 d10: M154 d14: M158	d03: M147 d07: M151 d11: M155 d15: M159	<p>Bit specified in every 1 points 0: Hold; 1: Clear</p> <div style="border: 1px solid black; padding: 5px; margin-top: 10px;"> <p>The values of the user registers whose specified bit is set to 1 will be "0" when the power is ON.</p> </div>
S4C845	d00: M160 d04: M164 d08: M168 d12: M172	d01: M161 d05: M165 d09: M169 d13: M173	d02: M162 d06: M166 d10: M170 d14: M174	d03: M163 d07: M167 d11: M171 d15: M175	
S4C846	d00: M176 d04: M180 d08: M184 d12: M188	d01: M177 d05: M181 d09: M185 d13: M189	d02: M178 d06: M182 d10: M186 d14: M190	d03: M179 d07: M183 d11: M187 d15: M191	
S4C847	d00: M192 d04: M196 d08: M200 d12: M204	d01: M193 d05: M197 d09: M201 d13: M205	d02: M194 d06: M198 d10: M202 d14: M206	d03: M195 d07: M199 d11: M203 d15: M207	
S4C848	d00: M208 d04: M212 d08: M216 d12: M220	d01: M209 d05: M213 d09: M217 d13: M221	d02: M210 d06: M214 d10: M218 d14: M222	d03: M211 d07: M215 d11: M219 d15: M223	
S4C849	d00: M224 d04: M228 d08: M232 d12: M236	d01: M225 d05: M229 d09: M233 d13: M237	d02: M226 d06: M230 d10: M234 d14: M238	d03: M227 d07: M231 d11: M235 d15: M239	
S4C850	d00: M240 d04: M244 d08: M248 d12: M252	d01: M241 d05: M245 d09: M249 d13: M253	d02: M242 d06: M246 d10: M250 d14: M254	d03: M243 d07: M247 d11: M251 d15: M255	
S4C851	d00: M256 d04: M260 d08: M264 d12: M268	d01: M257 d05: M261 d09: M265 d13: M269	d02: M258 d06: M262 d10: M266 d14: M270	d03: M259 d07: M263 d11: M267 d15: M271	
S4C852	d00: M272 d04: M276 d08: M280 d12: M284	d01: M273 d05: M277 d09: M281 d13: M285	d02: M274 d06: M278 d10: M282 d14: M286	d03: M275 d07: M279 d11: M283 d15: M287	
S4C853	d00: M288 d04: M292 d08: M296 d12: M300	d01: M289 d05: M293 d09: M297 d13: M301	d02: M290 d06: M294 d10: M298 d14: M302	d03: M291 d07: M295 d11: M299 d15: M303	

S4C854	d00: M304	d01: M305	d02: M306	d03: M307	<p>Bit specified in every 1 points 0: Hold; 1: Clear</p> <div style="border: 1px solid black; padding: 5px; margin-top: 10px;"> <p>The values of the user registers whose specified bit is set to 1 will be "0" when the power is ON.</p> </div>
	d04: M308	d05: M309	d06: M310	d07: M311	
d08: M312	d09: M313	d10: M314	d11: M315		
d12: M316	d13: M317	d14: M318	d15: M319		
S4C855	d00: M320	d01: M321	d02: M322	d03: M323	
	d04: M324	d05: M325	d06: M326	d07: M327	
d08: M328	d09: M329	d10: M330	d11: M331		
d12: M332	d13: M333	d14: M334	d15: M335		
S4C856	d00: M336	d01: M337	d02: M338	d03: M339	
	d04: M340	d05: M341	d06: M342	d07: M343	
d08: M344	d09: M345	d10: M346	d11: M347		
d12: M348	d13: M349	d14: M350	d15: M351		
S4C857	d00: M352	d01: M353	d02: M354	d03: M355	
	d04: M356	d05: M357	d06: M358	d07: M359	
d08: M360	d09: M361	d10: M362	d11: M363		
d12: M364	d13: M365	d14: M366	d15: M367		
S4C858	d00: M368	d01: M369	d02: M370	d03: M371	
	d04: M372	d05: M373	d06: M374	d07: M375	
d08: M376	d09: M377	d10: M378	d11: M379		
d12: M380	d13: M381	d14: M382	d15: M383		
S4C859	d00: M384	d01: M385	d02: M386	d03: M387	
	d04: M388	d05: M389	d06: M390	d07: M391	
d08: M392	d09: M393	d10: M394	d11: M395		
d12: M396	d13: M397	d14: M398	d15: M399		
S4C860	d00: M400	d01: M401	d02: M402	d03: M403	
	d04: M404	d05: M405	d06: M406	d07: M407	
d08: M408	d09: M409	d10: M410	d11: M411		
d12: M412	d13: M413	d14: M414	d15: M415		
S4C861	d00: M416	d01: M417	d02: M418	d03: M419	
	d04: M420	d05: M421	d06: M422	d07: M423	
d08: M424	d09: M425	d10: M426	d11: M427		
d12: M428	d13: M429	d14: M430	d15: M431		
S4C862	d00: M432	d01: M433	d02: M434	d03: M435	
	d04: M436	d05: M437	d06: M438	d07: M439	
d08: M440	d09: M441	d10: M442	d11: M443		
d12: M444	d13: M445	d14: M446	d15: M447		
S4C863	d00: M448	d01: M449	d02: M450	d03: M451	
	d04: M452	d05: M453	d06: M454	d07: M455	
d08: M456	d09: M457	d10: M458	d11: M459		
d12: M460	d13: M461	d14: M462	d15: M463		

S4C864	d00: M464	d01: M465	d02: M466	d03: M467	Bit specified in every 1 points 0: Hold; 1: Clear <div style="border: 1px solid black; padding: 5px; margin-top: 10px;"> The values of the user registers whose specified bit is set to 1 will be "0" when the power is ON. </div>
	d04: M468	d05: M469	d06: M470	d07: M471	
	d08: M472	d09: M473	d10: M474	d11: M475	
	d12: M476	d13: M477	d14: M478	d15: M479	
S4C865	d00: M480	d01: M481	d02: M482	d03: M483	
	d04: M484	d05: M485	d06: M486	d07: M487	
	d08: M488	d09: M489	d10: M490	d11: M491	
	d12: M492	d13: M493	d14: M494	d15: M495	
S4C866	d00: M496	d01: M497	d02: M498	d03: M499	
	d04: M500	d05: M501	d06: M502	d07: M503	
	d08: M504	d09: M505	d10: M506	d11: M507	
	d12: M508	d13: M509	d14: M510	d15: M511	
S4C867	d00: M512	d01: M513	d02: M514	d03: M515	
	d04: M516	d05: M517	d06: M518	d07: M519	
	d08: M520	d09: M521	d10: M522	d11: M523	
	d12: M524	d13: M525	d14: M526	d15: M527	
S4C868	d00: M528	d01: M529	d02: M530	d03: M531	
	d04: M532	d05: M533	d06: M534	d07: M535	
	d08: M536	d09: M537	d10: M538	d11: M539	
	d12: M540	d13: M541	d14: M542	d15: M543	
S4C869	d00: M544	d01: M545	d02: M546	d03: M547	
	d04: M548	d05: M549	d06: M550	d07: M551	
	d08: M552	d09: M553	d10: M554	d11: M555	
	d12: M556	d13: M557	d14: M558	d15: M559	



It is configurable if the register values allocated to the current TMR, CNT, and MLTMR instruction values should be retained in the parameters below or cleared when the power is turned ON.

S2C488=0:

- The current register values for TMR, CNT, and MLTMR instructions will be configured in the register's setting values.

S2C488=1:

- The current register value for CNT instruction shall be retained.
- The current register values for TMR and MLTMR instructions will be configured in the register's setting values.

S2C488=2:

- The current register values for CNT instruction will be configured in the register's setting values.
- The current register value for TMR and MLTMR instructions shall be retained.

S2C488=3:

- The current register value for TMR, CNT, and MLTMR instructions shall be retained.

FS100 OPTIONS INSTRUCTIONS

FOR CONCURRENT I/O

HEAD OFFICE

2-1 Kurosakishiroishi, Yahatanishi-ku, Kitakyushu 806-0004, Japan
Phone +81-93-645-7745 Fax +81-93-645-7746

YASKAWA America Inc. M Robotics Division
100 Automation Way, Miamisburg, OH 45342, U.S.A.
Phone +1-937-847-6200 Fax +1-937-847-6277

YASKAWA Nordic AB
Box 504 Verkstadsgatan 2, PO Box 504 SE-385 25 Torsås, Sweden
Phone +46-480-417-800 Fax +46-486-414-10

YASKAWA Europe GmbH Robotics Div.
Yaskawastrasse 1, 85391 Allershausen, Germany
Phone +49-8166-90-0 Fax +49-8166-90-103

YASKAWA Electric Korea Co., Ltd
9F, KYOBO Securities Bldg., 26-4, Yeoido-Dong Yeoungpo-ku, Seoul, Korea
Phone +82-2-784-7844 Fax +82-2-784-8495

YASKAWA Electric (Singapore) PTE Ltd.
151 Lorong Chuan, #04-02A, New Tech Park, Singapore 556741
Phone +65-6282-3003 Fax +65-6289-3003

YASKAWA Electric (Thailand) Co., Ltd.
252/246, 4th Floor, Muang Thai-Phatra Office Tower II Rachadaphisek Road,
Huaykwang Bangkok, 10320, Thailand
Phone +66-2-693-2200 Fax +66-2-693-4200

YASKAWA Shougang Robot Co. Ltd.
1015, Boxuenan Rd. Maluzhen, Jiading District, Shanghai, China
Phone +86-21-5950-3521 Fax +86-20-3878-0651

YASKAWA ELECTRIC CHINA Co., Ltd.
12F Carlton Building, No. 21-42 Huanghe Road, Shanghai 200003, China
Phone +86-21-5385-2200 Fax +86-21-5385-3299

YASKAWA Robotics India Ltd.
#426, Udyog Vihar, Phase- IV, Gurgaon, Haryana, India
Phone +91-124-475-8500 Fax +91-124-475-8542

Specifications are subject to change without notice
for ongoing product modifications and improvements.

MANUAL NO. RE-CKI-A460 