

DX100 OPTIONS INSTRUCTIONS

FOR BRAKE RELEASE UNIT INSTALLED IN CONTROLLER CABINET

Upon receipt of the product and prior to initial operation, read these instructions thoroughly, and retain for future reference.

MOTOMAN INSTRUCTIONS

MOTOMAN-□□□ INSTRUCTIONS
DX100 INSTRUCTIONS
DX100 OPERATOR'S MANUAL
DX100 MAINTENANCE MANUAL

The DX100 operator's manual above corresponds to specific usage.
Be sure to use the appropriate manual.

Part Number: 158967-1CD

Revision: 0



MANDATORY

- This manual explains the brake release unit of the DX100 system. Read this manual carefully and be sure to understand its contents before handling the DX100.
- General items related to safety are listed in the Chapter 1: Safety of the DX100 Instructions. To ensure correct and safe operation, carefully read the DX100 Instructions before reading this manual.



CAUTION

- Some drawings in this manual are shown with the protective covers or shields removed for clarity. Be sure all covers and shields are replaced before operating this product.
- The drawings and photos in this manual are representative examples and differences may exist between them and the delivered product.
- YASKAWA may modify this model without notice when necessary due to product improvements, modifications, or changes in specifications. If such modification is made, the manual number will also be revised.
- If your copy of the manual is damaged or lost, contact a YASKAWA representative to order a new copy. The representatives are listed on the back cover. Be sure to tell the representative the manual number listed on the front cover.
- YASKAWA is not responsible for incidents arising from unauthorized modification of its products. Unauthorized modification voids your product's warranty.

NOTES FOR SAFE OPERATION

Read this manual carefully before installation, operation, maintenance, or inspection of the DX100.

In this manual, the Notes for Safe Operation are classified as “WARNING”, “CAUTION”, “MANDATORY”, or “PROHIBITED”.



WARNING

Indicates a potentially hazardous situation which, if not avoided, could result in death or serious injury to personnel.



CAUTION

Indicates a potentially hazardous situation which, if not avoided, could result in minor or moderate injury to personnel and damage to equipment. It may also be used to alert against unsafe practices.



MANDATORY

Always be sure to follow explicitly the items listed under this heading.



PROHIBITED

Must never be performed.

Even items described as “CAUTION” may result in a serious accident in some situations. At any rate, be sure to follow these important items.



To ensure safe and efficient operation at all times, be sure to follow all instructions, even if not designated as “CAUTION” and “WARNING”.



WARNING

- Before operating the manipulator, check that servo power is turned OFF when the emergency stop buttons on the front door of the DX100 and the programming pendant are pressed. When the servo power is turned OFF, the SERVO ON LED on the programming pendant is turned OFF.

Injury or damage to machinery may result if the emergency stop circuit cannot stop the manipulator during an emergency. The manipulator should not be used if the emergency stop buttons do not function.

Fig. : Emergency Stop Button



- Once the emergency stop button is released, clear the cell of all items which could interfere with the operation of the manipulator. Then turn the servo power ON.

Injury may result from unintentional or unexpected manipulator motion.

Fig. : Release of Emergency Stop



- Observe the following precautions when performing teaching operations within the P-point maximum envelope of the manipulator:
 - View the manipulator from the front whenever possible.
 - Always follow the predetermined operating procedure.
 - Keep in mind the emergency response measures against the manipulator's unexpected motion toward you.
 - Ensure that you have a safe place to retreat in case of emergency.

Improper or unintended manipulator operation may result in injury.

- Confirm that no person is present in the P-point maximum envelope of the manipulator and that you are in a safe location before:
 - Turning ON the DX100 power
 - Moving the manipulator with the programming pendant
 - Running the system in the check mode
 - Performing automatic operations

Injury may result if anyone enters the P-point maximum envelope of the manipulator during operation. Always press an emergency stop button immediately if there is a problem. The emergency stop buttons are located on the right of the front door of the DX100 and the programming pendant.



CAUTION

- Perform the following inspection procedures prior to conducting manipulator teaching. If problems are found, repair them immediately, and be sure that all other necessary processing has been performed.
 - Check for problems in manipulator movement.
 - Check for damage to insulation and sheathing of external wires.
- Always return the programming pendant to the hook on the DX100 cabinet after use.

The programming pendant can be damaged if it is left in the manipulator's work area, on the floor, or near fixtures.

- Read and understand the Explanation of the Warning Labels in the DX100 Instructions before operating the manipulator.

Definition of Terms Used Often in This Manual

The MOTOMAN is the YASKAWA industrial robot product.

The MOTOMAN usually consists of the manipulator, the controller, the programming pendant, and manipulator cables.

In this manual, the equipment is designated as follows:

Equipment	Manual Designation
DX100 Controller	DX100
DX100 Programming Pendant	Programming Pendant

DX100

Descriptions of the programming pendant keys, buttons, and displays are shown as follows:

Equipment		Manual Designation
Programming Pendant	Character Keys	The keys which have characters printed on them are denoted with []. ex. [ENTER]
	Symbol Keys	The keys which have a symbol printed on them are not denoted with [] but depicted with a small picture. ex. page key  The cursor key is an exception, and a picture is not shown.
	Axis Keys Numeric Keys	“Axis Keys” and “Numeric Keys” are generic names for the keys for axis operation and number input.
	Keys pressed simultaneously	When two keys are to be pressed simultaneously, the keys are shown with a “+” sign between them, ex. [SHIFT]+[COORD]
	Displays	The menu displayed in the programming pendant is denoted with { }. ex. {JOB}

Description of the Operation Procedure

In the explanation of the operation procedure, the expression “Select •••” means that the cursor is moved to the object item and the SELECT key is pressed.

Registered Trademark

In this manual, names of companies, corporations, or products are trademarks, registered trademarks, or brand names for each company or corporation. The indications of (R) and TM are omitted.

DX100

1	Introduction	1-1
2	Installation and Wiring.....	2-1
2.1	Installation	2-1
2.2	Wiring.....	2-2
3	Operating Procedure.....	3-1
4	Maintenance	4-1

1 Introduction

With the brake release unit, the motor brake can be forcibly released by using the manual switch even if the manipulator or external axis cannot be operated.

Fig. 1-1: Brake Release Unit Installed in the Controller Cabinet

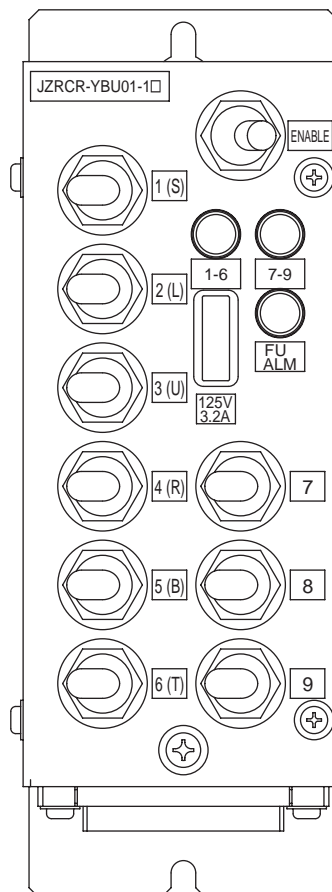

2 Installation and Wiring

2.1 Installation

Fix the brake release unit on the inside surface of the door. (See *fig. 2-1 "Example of the Place to Fix the Brake Release Unit"* .) Note that the place to fix it may differ depending on the specification.

If the brake release unit is already installed in the controller cabinet, this procedure is not needed.



CAUTION

- Check to be sure that the main breaker of the DX100 is turned OFF before installing the brake release unit.

Electric shock or equipment damage may result.

- Make sure to fix the brake release unit.

Equipment damage or personal injury may result due to the falling of the unit.

Fig. 2-1: Example of the Place to Fix the Brake Release Unit

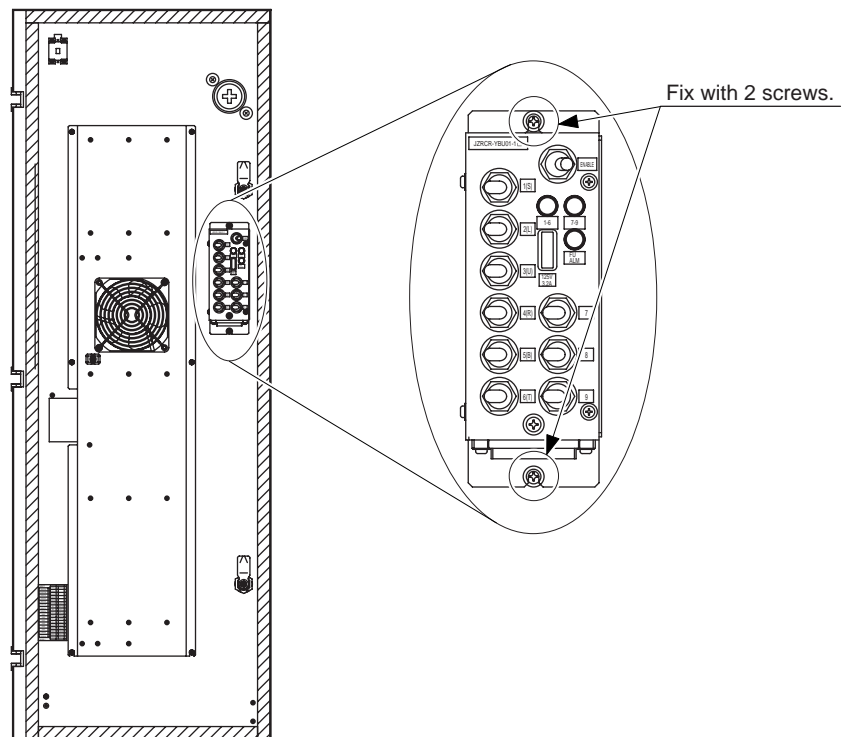

Inside Surface of the Door

2.2 Wiring

Connect the connector CN410 of the brake release unit and the connector CN401 of the brake control board (JANCD-YBK01-2E) with the cable. (See fig. 2-2 "Wiring Between the Brake Release Unit and the Brake Control Board".)

If the brake release unit is already installed and wired in the controller cabinet, this procedure is not needed.



CAUTION

- Check to be sure that the main breaker of the DX100 is turned OFF before wiring the brake release unit.

Electric shock or equipment damage may result.

- Make sure to fix the brake release unit in the controller cabinet before wiring it.

Equipment damage, cable disconnection, or personal injury may result due to the falling of the unit.

Fig. 2-2: Wiring Between the Brake Release Unit and the Brake Control Board

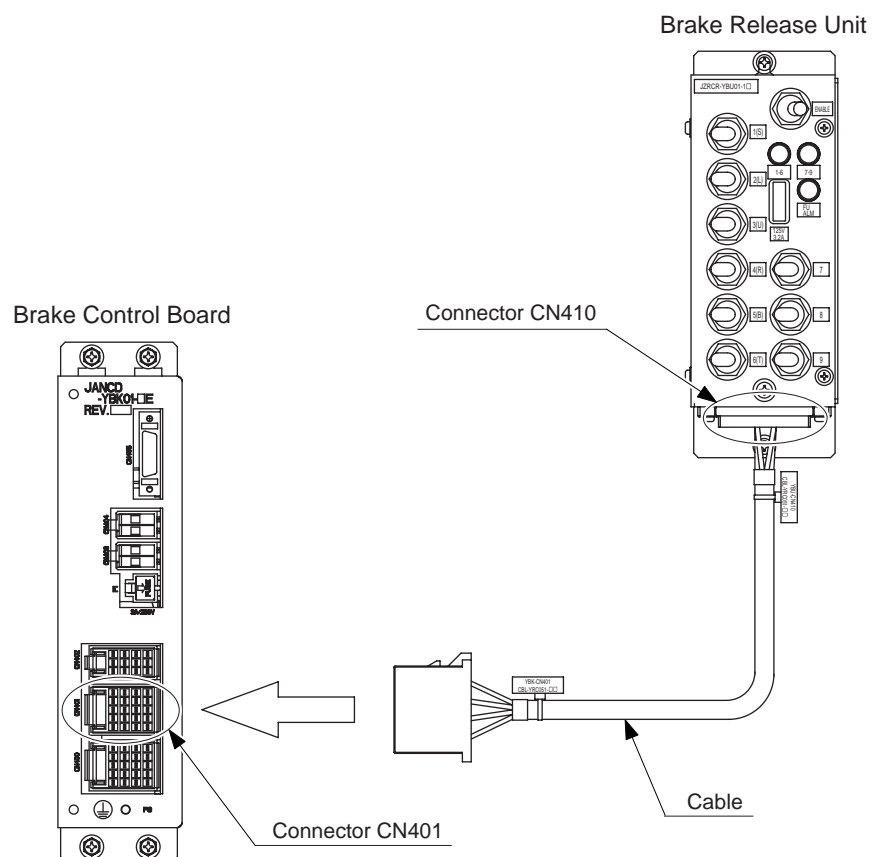

The brake release unit can be connected to the brake control board JANCD-YBK01-2E. It cannot be connected to JANCD-YBK01-1E.

3 Operating Procedure



CAUTION

- When releasing the brake, pay attention to surroundings.

The robot arm may move under its own weight, and personal injury or equipment damage may result.

- Release the brake for one axis at a time.

If the brakes of multiple axes are released out of necessity, the robot arm may move in an unexpected way. Pay attention to surroundings. Personal injury or equipment damage may result.

1. Turn ON the breaker.
2. Move the ENABLE switch of the brake release unit to the left.
(Power lights "1-6" and "7-9" light up.)
3. While the ENABLE switch is moved to the left, move an axis selection switch to the right. The brake of the axis is released while the axis selection switch is pressed.
4. To remove the brake release unit after the operation, turn OFF the breaker, then remove the brake release unit in the reverse order of the procedure described in *chapter 2 "Installation and Wiring"*.

Fig. 3-1: Switches and Lights of the Brake Release Unit

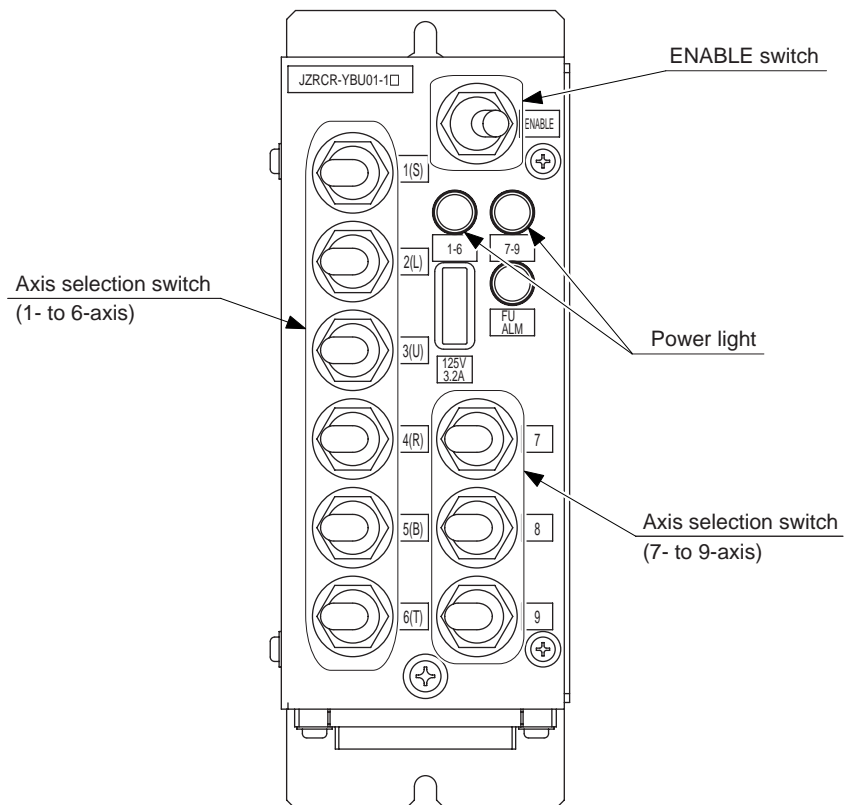

4 Maintenance

A fuse is installed in the brake release unit to prevent overcurrent due to the short circuit of the brake line, etc. If the fuse is blown, the blown fuse light (red) on the front of the unit lights up. Repair the defective part, and replace the fuse with a new one.

Fuse type: MP32

(manufactured by Daito Communication Apparatus Co., Ltd.)

Fig. 4-1: Fuse and Light of the Brake Release Unit

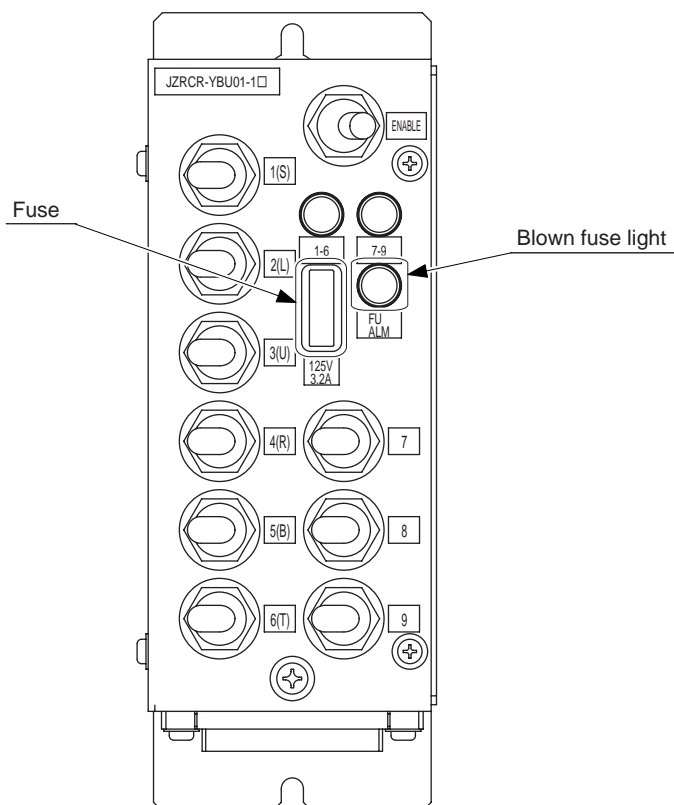

DX100 OPTIONS INSTRUCTIONS

FOR BRAKE RELEASE UNIT INSTALLED IN CONTROLLER CABINET

HEAD OFFICE

2-1 Kurosakishiroishi, Yahatanishi-ku, Kitakyushu 806-0004 Japan
Phone +81-93-645-7745 Fax +81-93-645-7746

YASKAWA America Inc. MOTOMAN Robotics Division
805 Liberty Lane, West Carrollton, OH 45449, U.S.A.
Phone +1-937-847-6200 Fax +1-937-847-6277

YASKAWA Nordic AB
Franska vagen 10, Box 4004, 390 04 Kalmar, Sweden
Phone +46-480-417800 Fax +46-480-417999

YASKAWA Europe GmbH Robotics Division
Kammerfeld strasse 1, 85391 Allershausen, Germany
Phone +49-8166-90-100 Fax +49-8166-90-103

YASKAWA Electric Korea Co., Ltd.
7F, Doore Bldg.; 24, Yeoido-Dong Youngdungpo-ku, Seoul, KOREA
Phone +82-2-784-7844 Fax +82-2-784-8495

YASKAWA Electric (Singapore) PTE Ltd.
151 Lorong Chuan, #04-02A, New Tech Park, Singapore 556741
Phone +65-6282-3003 Fax +65-6289-3003

YASKAWA Electric (Thailand) Co., Ltd.
252/246, 4th Floor. Muang Thai-Phatra Office Tower II Rachadaphisek Road, Huaykwang Bangkok, 10320 Thailand
Phone +66-2-693-2200 Fax +66-2-693-4200

Shougang MOTOMAN Robot Co. Ltd.
No.7, Yongchang-North Road, Beijing E&T Development Area, China 100176
Phone +86-10-6788-2858 Fax +86-10-6788-2878

MOTOMAN Motherson Robotics Ltd.
Plot No.195-196, 1st Floor, Sec.4 IMT Manesar, Gurgaon 122050, Haryana
Phone +91-124-475-8500 Fax +91-124-414-8016

Specifications are subject to change without notice
for ongoing product modifications and improvements.